

From the INTERNATIONAL BUREAU

PCTCOMMUNICATION IN CASES FOR WHICH
NO OTHER FORM IS APPLICABLE

To:

EHRlich, Gal
G. E. EHRlich (1995) LTD.
11 Menachem Begin Road,
5268104 Ramat-Gan
ISRAËL

Date of mailing (<i>day/month/year</i>) 23 April 2020 (23.04.2020)	
Applicant's or agent's file reference 80842	REPLY DUE see paragraph 1 below
International application No. PCT/IL2020/050387	International filing date (<i>day/month/year</i>) 30 March 2020 (30.03.2020)
Applicant STRATASYS LTD.	

1. REPLY DUE within months/days from the above date of mailing
 NO REPLY DUE, however, see below
 IMPORTANT COMMUNICATION
 INFORMATION ONLY

2. COMMUNICATION:

The International Bureau received a copy of the request for correction of the numbering of drawing 1C, under Rule 91.

The applicant and Receiving office are informed that this mail is attached for transmission to ISA/EP, the authorized Authority to check and accept this correction.

Thank you.

The International Bureau of WIPO 34, chemin des Colombettes 1211 Geneva 20, Switzerland	Authorized officer Fahy Laurence e-mail pct.team9@wipo.int Telephone No. +41 22 338 74 09
---	---



The Rogovin-Tidhar Tower, 15th Floor, 11 Menachem Begin Road, 5268104 Ramat-Gan, Israel
Tel: +972-73-7919199, Fax: +972-73-7919100, patents@ipatent.co.il, www.ipatent.co.il

13 April, 2020

Attention: Authorized Officer TSODIKOV David
ISRAEL PATENT OFFICE
P.C.T. DIVISION
1 Agudat HaSport Road
HaGan HaTechnology, Building no. 5
96951 Jerusalem

Dear Sirs,

Re : PCT Patent Application No. PCT/IL2020/050387

Filed: 30 March 2020

By : Stratasys Ltd. (Inventor: GLASSMAN Barak)

For : METHOD AND SYSTEM FOR LEVELING A LAYER IN FREEFORM FABRICATION

Agent Ref: 80842

RESPONSE TO PCT/RO/132 DATED 2 APRIL 2020

RECTIFICATION OF OBVIOUS MISTAKE UNDER RULE 91.1

Further to Form PCT/RO/132 issued on 2 April 2020, attached is the amended page 2 of the figures.

The amendments are obvious to correct because they merely relate to the numbering of the figures, and not to subject matter in any way.

Yours very truly,

Dr. Gal Ehrlich (AB)

Agent on behalf of Applicant

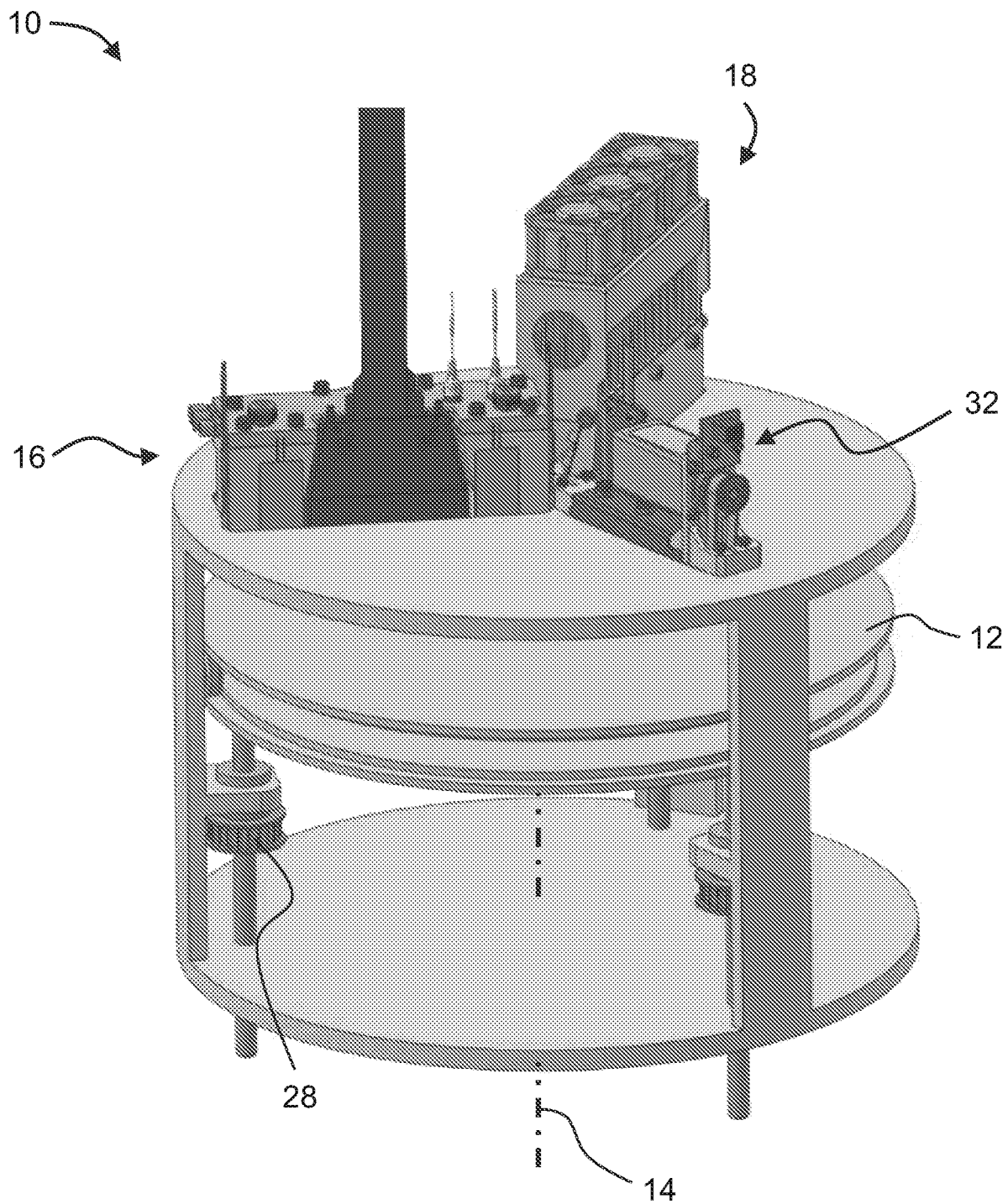

FIG. 1C