



(51) International Patent Classification:

H01H 85/08 (2006.01) H01H 85/36 (2006.01)

(21) International Application Number:

PCT/SI2018/000026

(22) International Filing Date:

05 December 2018 (05.12.2018)

(25) Filing Language:

Slovenian

(26) Publication Language:

English

(30) Priority Data:

P-201800261 29 November 2018 (29.11.2018) SI

(71) Applicant: **RAZVOJNI CENTER ENEM NOVI MATERIALI D.O.O.** [SI/SI]; Podvine 36, 1410 Zagorje ob Savi (SI).

(72) Inventors: **LEBAR, Brane**; Rove 19, 1410 Zagorje ob Savi (SI). **KOS, Darko**; Borovak pri Podkumu 6, 1414 Podkum (SI).

(74) Agent: **BORSTAR, Dusan**; Nova ulica 11, 1230 Domzale (SI).

(81) Designated States (unless otherwise indicated, for every kind of national protection available): AE, AG, AL, AM,

AO, AT, AU, AZ, BA, BB, BG, BH, BN, BR, BW, BY, BZ, CA, CH, CL, CN, CO, CR, CU, CZ, DE, DJ, DK, DM, DO, DZ, EC, EE, EG, ES, FI, GB, GD, GE, GH, GM, GT, HN, HR, HU, ID, IL, IN, IR, IS, JO, JP, KE, KG, KH, KN, KP, KR, KW, KZ, LA, LC, LK, LR, LS, LU, LY, MA, MD, ME, MG, MK, MN, MW, MX, MY, MZ, NA, NG, NI, NO, NZ, OM, PA, PE, PG, PH, PL, PT, QA, RO, RS, RU, RW, SA, SC, SD, SE, SG, SK, SL, SM, ST, SV, SY, TH, TJ, TM, TN, TR, TT, TZ, UA, UG, US, UZ, VC, VN, ZA, ZM, ZW.

(84) Designated States (unless otherwise indicated, for every kind of regional protection available): ARIPO (BW, GH, GM, KE, LR, LS, MW, MZ, NA, RW, SD, SL, ST, SZ, TZ, UG, ZM, ZW), Eurasian (AM, AZ, BY, KG, KZ, RU, TJ, TM), European (AL, AT, BE, BG, CH, CY, CZ, DE, DK, EE, ES, FI, FR, GB, GR, HR, HU, IE, IS, IT, LT, LU, LV, MC, MK, MT, NL, NO, PL, PT, RO, RS, SE, SI, SK, SM, TR), OAPI (BF, BJ, CF, CG, CI, CM, GA, GN, GQ, GW, KM, ML, MR, NE, SN, TD, TG).

Published:

— with international search report (Art. 21(3))

(54) Title: ELECTRO THERMAL FUSE

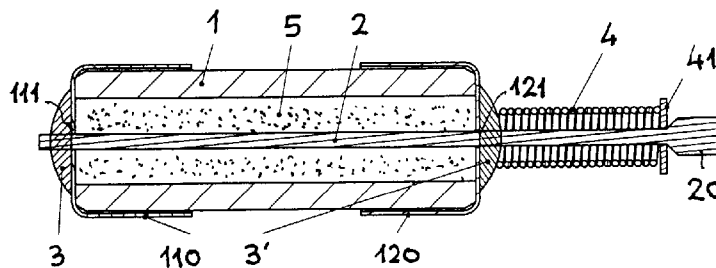

Fig. 3

(57) Abstract: The underlying problem of the invention is how to create such electric thermal fuse, in which the electric circuit through the fuse is interrupted in a shortest possible time, as soon as even relatively high voltage or current is exceeded, and regardless to position/orientation of the fuse, while at the same time it should also be assured that each generated electric arc, whenever occurs, would have any essential impact neither to the fuse nor to each surrounding area in the adjacency thereof. The invention provides that a tubular casing (1) of such fuse consists of ceramics, and each of said contact members (110, 120) is furnished with at least approximately centrally arranged throughout passage (111, 121), so that the electric conductor (2) is inserted through said passages (111, 121) within said contact members (110, 120) and is by means of solder (3, 3'), which is located on the external side of the fuse, firmly and electric conductively connected with each of said contact members (110, 120), wherein said conductor (2) is in the one terminal area of the fuse extended and ended with appropriate thicker portion (20), so that a spring (4) is placed around said conductor (2) and is inserted between said thicker portion (20) and the belonging contact member (120) with said solder (3'), and wherein the residual volume within said passage (10) in the casing (1) of the fuse, namely the area between said conductor (2) and the casing (1) as well as between said contact members (110, 120), is filled with a pre-determined quantity of arc preventing filler (5) of the basis of properly granulated silica.



### **Electro thermal fuse**

The present invention refers to an electric thermal fuse, the features of which are presented in more detail in a subsequent description. Pursuant to the International Patent Classification such inventions belong to electricity, namely to basic electric components, in particular to electric switches and protecting components, in which the current flows through a part of melting material and is interrupted as soon as said melting material is displaced due to excessive current, wherein the casing is filled with a filling material in powder form. Consequently, such invention belongs to the class A 01 H 85/18.

The underlying problem of the invention is how to create such electric thermal fuse, in which the electric circuit through the fuse is interrupted in a shortest possible time, as soon as even relatively high voltage or current is exceeded, and regardless to position/orientation of the fuse, while at the same time it should also be assured that each generated electric arc, whenever occurs, would have any essential impact neither to the fuse nor to each surrounding area in the adjacency thereof.

Electric thermal fuse is intended for protection of an electric circuit, and in particular of each particular component integrated therein, e.g. varistor fuses as well as of other over-voltage protecting components. This means that the electro thermal fuse reacts to a heat, which is due to electric overloads generated either within the fuse as such or also in each neighboring electric component within the same electric circuit. Such fuse is disclosed in JP 2016-162683 A and comprises a tubular casing, which consists of an electric insulating material and is on its both terminal portions furnished with contact members, by means of which said fuse is electrically connectable to each disposable electric circuit. An electric conductor extends through the passage within said casing, and is by means of solder connected on the one hand with one of said contact members and on the other hand with a tension helical spring, which is attached to the other contact member. As soon as in certain circuit an overload occurs, the heat is generated and transferred towards the interior of the fuse and up to said soldered contact between the electric conductor and corresponding contact member. Said solder is then molten at a predetermined temperature, upon which said interconnection between said conductor and corresponding contact member is interrupted, and the conductor is by means of said spring displaced apart from said contact member. In particular in high-voltage circuits such displacement of the conductor apart from the contact member results in formation of a very intensive arc, which may quickly and seriously damage the casing and objects in the neighborhood of the fuse, or initiate the fire.

Electro thermal fuse according to the invention comprises a tubular casing consisting of electric insulating material, which is on each of its terminal portions closed by a cover, which is also functioning as a contact member consisting of an electric conductive material, which is suitable for integration of the fuse into each disposable electric circuit. An electric conductor is inserted throughout the passage within said hollow casing and is during the normal operation of the fuse, namely

when the electric current is allowed to flow through said electric conductor, via at least one contact established by solder electrically interconnected with said contact members, but is in the case of the electric overload within said circuit and generated heat and consequently melting and interruption of said at least one soldered contact displaceable away from at least one of said contact members by means of a spring, by which the electric current through the fuse is then interrupted.

The invention provides that said tubular casing consists of ceramics, and each of said contact members is furnished with at least approximately centrally arranged throughout passage, so that the electric conductor is inserted through said passages within said contact members and is by means of solder, which is located on the external side of the fuse, firmly and electric conductively connected with each of said contact members. Said conductor is in the one terminal area of the fuse extended and ended with appropriate thicker portion, so that a spring is placed around said conductor and is inserted between said thicker portion and the belonging contact member with said solder. Each residual volume within said passage in the casing of the fuse, namely the area between said conductor and the casing as well as between said contact members, is filled with a pre-determined quantity of arc preventing filler on the basis of properly granulated silica.

In a preferred embodiment of the invention said conductor is a wire consisting of copper and having a pre-determined circular cross-section, an said spring is a compression helical spring. Moreover, a washer, which is suitable for supporting said spring, can be inserted between said spring and said thicker portion on the conductor.

A suitable quantity of filler on the basis of properly granulated silica is determined in such manner is such, that the volume of the filler as such corresponds to approximately 90% of the whole disposable volume around the conductor within said passage within the casing. Said solder, which is foreseen for connection of the conductor with each corresponding contact member, is selected in such manner that its melting point is adjusted within the range 105 – 115°C.

The invention will also be explained in more detail on the basis of an embodiment, which is presented in the attached drawings, in which

Fig. 1 is an electric thermal fuse in isometric view;

Fig. 2 is the fuse according to Fig. 1 in front view; and

Fig. 3 the fuse according to Figs. 1 and 2 in longitudinal cross-section in its diametrical plane.

Electro thermal fuse generally, and also in the embodiment according to Figs. 1 – 3, comprises a tubular casing 1, which is made of an electric insulating material, and is on each of its terminal portions 11, 12 closed by a cover, which is in fact also functioning as a contact member 110, 120 consisting of an electric conductive material, which is suitable for integration of the fuse into each disposable electric circuit. An electric conductor 2 is inserted throughout the passage 10 within said hollow casing 1.

Said conductor 2 is during the normal operation of the fuse, namely when the electric current is allowed to flow through said electric conductor 2, via at least one soldered contact 3, 3' electrically interconnected with said contact members 110, 120, but is in the case of the electric overload within said circuit and generated heat and consequently melting and interruption of said at least one soldered contact 3, 3' displaceable away from at least one of said contact members

110, 120 by means of a spring 4, by which then the electric current through the fuse is then interrupted.

In accordance with the present invention said tubular casing 1 consists of ceramics, and is therefore not only electric insulating but also highly temperature resistant and inflammable.

Each of said contact members 110, 120 is furnished with at least approximately centrally arranged throughout passage 111, 121, so that said electric conductor 2 is inserted through said passages 111, 121 within said contact members 110, 120 and is by means of solder 3, 3', which is located on the external side of the fuse, firmly and electric conductively connected with each of said contact members 110, 120. Said conductor 2 is in the one terminal area of the fuse extended and ended with appropriately thicker portion 20, so that a spring 4 can be placed around said conductor 2 and is then jammed between said thicker portion 20 and the belonging contact member 120 with said solder 3'.

Each residual volume within said passage 10 in the casing 1 of the fuse, namely the area between said conductor 2 and the casing 1 as well as between said contact members 110, 120, is filled with a pre-determined quantity of arc preventing filler 5 of the basis of silica, wherein the granulation of the last is preferably 0,2 to 0,4 mm. Quantity of said filler 5 on the basis of silica is determined in such manner, that the volume of the filler 5 as such corresponds to approximately 90% of the whole disposable volume around the conductor 2 within said passage 10 within the casing 1.

In the shown embodiment of the invention said spring 4 is a compression helical spring, and a washer 6, which is suitable for supporting said spring 4, is inserted

between said spring 4 and said thicker portion 20 on the conductor 2. As a result of such concept, as soon as the spring 4 is placed around the conductor 2 and compressed, and subsequently also the washer 6 is set in position, said thicker portion 20 can be easily realized by locally flattening said conductor 2, by which said spring 4 is maintained in compressed state until the solder 3, 3' is molten.

In a preferred embodiment of the fuse according to the invention said conductor 2 is a wire consisting of copper and having a pre-determined circular cross-section of e.g. 1,5 mm<sup>2</sup>. For such conductor 2 it is then quite satisfactory, if the diameter of passages 111, 121 in said contact members 110, 120 is approximately 1,5 mm. Suitable solder 3, 3' for connecting said conductor 2 with each belonging contact member 110, 120 is selected in such way, that its melting point is adjusted within the range 105 – 115°C, and e.g. for the purpose of protection of varistors in the adjacency substantially around 109 or 110°C.

As soon as such fuse is integrated within an electric circuit, the electric current starts flowing through the first contact member 110, the solder 3, the electric conductor 2, the solder 3' and the second contact member 120. The electric conductor is surrounded with a filler 5. As soon as excessive current occurs within said electric circuit and the temperature increases above a pre-determined value, which corresponds to the melting point of each solder 3, 3' like e.g. 105°C or e.g. 109°C, if chemical ingredients in the solder are correspondingly adjusted, the solder 3, 3' starts melting, upon which the previously compressed spring 4 may be released, which then results in displacement of the conductor away from at least one contact member 110, 120. Since such displacement of said conductor 2 apart from the contact member 110, 120 may, in particular in a high-voltage circuit, might lead to formation of arc between the conductor 2 and the contact member 110, 120, the invention provides that each disposal volume within the casing 1,

namely between the last and the conductor 2, is properly i.e. in certain extent filled by a filler on the basis of silica. Adjusting each suitable granulation of sand in said filler 5 is important for two reasons. Namely, on the one hand is herewith prevented that by introduction of too much filler 5, the silica sand, which is in general quite similarly like ceramics resistant against high temperature and inflammable, by axially displacing the conductor 2 in each possible position of the fuse, e.g. in vertical or horizontal or slanted position of the fuse, due to its abrasive properties, hinder said displacing in such extent that despite to sufficiently strong spring 4 said displacement would be decelerated, which could have negative impact to reacting ability of the fuse to each overload, since the time required for interruption of circuit, into which the fuse is integrated, could be herewith essentially prolonged. On the other hand, appropriate quantity and granulation of said in the filler 5 is also important for another reason, since during displacing the conductor 2 the sand is immediately and successively filling the space, which is formed behind the conductor 2 by displacing thereof and in which otherwise said arc could appear, so that said released space is promptly filled with a non-flammable and temperature resistant filler 5.

Thanks to such concept such fuse according to the invention is extremely efficient even in high-voltage electric circuits and regardless to each current position of the mounted fuse.



## PATENT CLAIMS

1. Electro thermal fuse, comprising a tubular casing (1) consisting of electric insulating material, which is on each of its terminal portions (11, 12) closed by a cover, which is also functioning as a contact member (110, 120) consisting of an electric conductive material, which is suitable for integration of the fuse into each disposable electric circuit, while an electric conductor (2) is inserted throughout the passage (10) within said hollow casing (1) and is during the normal operation of the fuse, namely when the electric current is allowed to flow through said electric conductor (2), via at least one soldered contact (3, 3') electrically interconnected with said contact members (110, 120), but is in the case of the electric overload within said circuit and generated heat and consequently melting and interruption of said at least one soldered contact (3, 3') displaceable away from at least one of said contact members (110, 120) by means of a spring (4), by which the electric current through the fuse is then interrupted, **characterized in that** said tubular casing (1) consists of ceramics, and each of said contact members (110, 120) is furnished with at least approximately centrally arranged throughout passage (111, 121), so that the electric conductor (2) is inserted through said passages (111, 121) within said contact members (110, 120) and is by means of solder (3, 3'), which is located on the external side of the fuse, firmly and electric conductively connected with each of said contact members (110, 120), wherein said conductor (2) is in the one terminal area of the fuse extended and ended with appropriate thicker portion (20), so that a spring (4) is placed around said conductor (2) and is inserted between said thicker portion (20) and the belonging contact member (120) with said solder (3'), and wherein the residual volume within said passage (10) in the casing (1) of the fuse, namely the area between said conductor (2) and the casing (1) as well as between said contact members (110, 120), is filled with a pre-

determined quantity of arc preventing filler (5) of the basis of properly granulated silica.

2. Fuse according to Claim 1, **characterized in that** said conductor (2) is a wire consisting of copper and having a pre-determined circular cross-section.

3. Fuse according to Claim 1 or 2, **characterized in that** a washer (6), which is suitable for supporting said spring (4), is inserted between said spring (4) and said thicker portion (20) on the conductor (2).

4. Fuse according to anyone of Claims 1 - 3, **characterized in that** said spring (4) is a compression helical spring.

5. Fuse according to anyone of Claims 1 - 4, **characterized in that** said quantity of filler (5) on the basis of properly granulated silica is determined in such manner, that the volume of the filler (5) as such corresponds to approximately 90% of the whole disposable volume around the conductor (2) within said passage (10) within the casing (1).

6. Fuse according to anyone of Claims 1 - 5, **characterized in that** the melting point of said solder (3, 3'), which is foreseen for connection of the conductor (2) with each corresponding contact member (110, 120), is adjusted within the range 105 – 115°C.

1/1

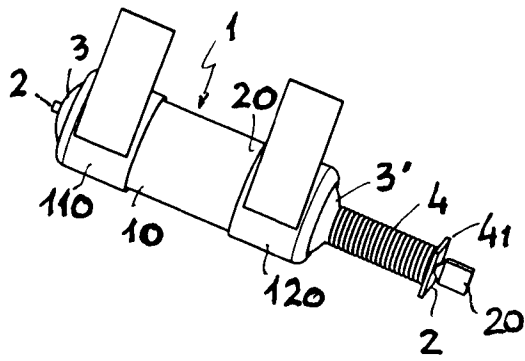

Fig. 1

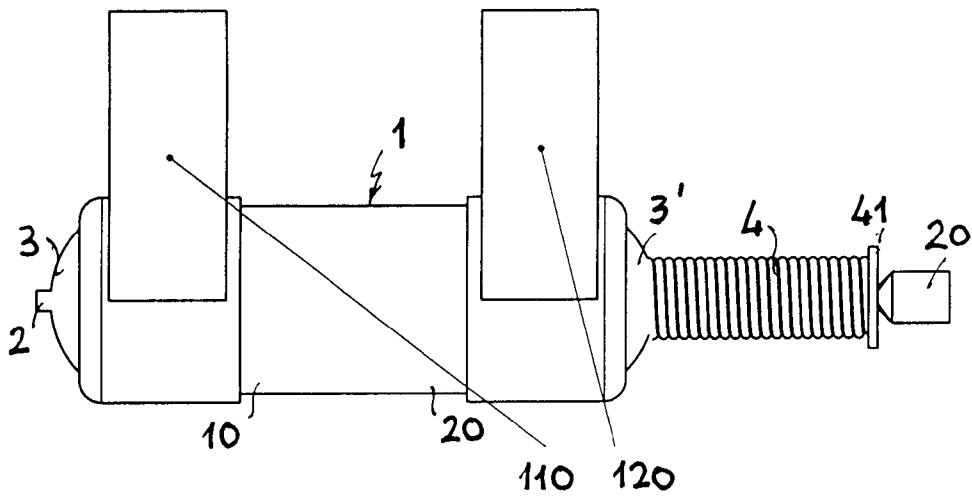

Fig. 2

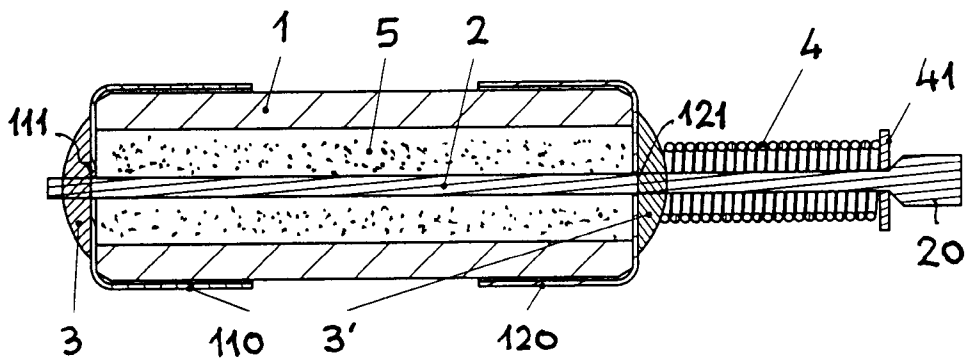

Fig. 3

INTERNATIONAL SEARCH REPORT

International application No  
PCT/SI2018/000026

A. CLASSIFICATION OF SUBJECT MATTER  
INV. H01H85/08 H01H85/36  
ADD.  
According to International Patent Classification (IPC) or to both national classification and IPC

B. FIELDS SEARCHED  
Minimum documentation searched (classification system followed by classification symbols)  
H01H  
Documentation searched other than minimum documentation to the extent that such documents are included in the fields searched

Electronic data base consulted during the international search (name of data base and, where practicable, search terms used)  
EPO-Internal, WPI Data

C. DOCUMENTS CONSIDERED TO BE RELEVANT		
Category*	Citation of document, with indication, where appropriate, of the relevant passages	Relevant to claim No.
A	JP 2016 162683 A (ORIENT:KK) 5 September 2016 (2016-09-05) column 1, line 39 - column 2, line 26; figure 1 -----	1-6
A	US 2 296 627 A (BROWN GEORGE R) 22 September 1942 (1942-09-22) figure 1 -----	1
A	GB 1 033 814 A (ENGLISH ELECTRIC CO LTD) 22 June 1966 (1966-06-22) the whole document -----	1

Further documents are listed in the continuation of Box C.

See patent family annex.

\* Special categories of cited documents :

<p>"A" document defining the general state of the art which is not considered to be of particular relevance</p> <p>"E" earlier application or patent but published on or after the international filing date</p> <p>"L" document which may throw doubts on priority claim(s) or which is cited to establish the publication date of another citation or other special reason (as specified)</p> <p>"O" document referring to an oral disclosure, use, exhibition or other means</p> <p>"P" document published prior to the international filing date but later than the priority date claimed</p>	<p>"T" later document published after the international filing date or priority date and not in conflict with the application but cited to understand the principle or theory underlying the invention</p> <p>"X" document of particular relevance; the claimed invention cannot be considered novel or cannot be considered to involve an inventive step when the document is taken alone</p> <p>"Y" document of particular relevance; the claimed invention cannot be considered to involve an inventive step when the document is combined with one or more other such documents, such combination being obvious to a person skilled in the art</p> <p>"&amp;" document member of the same patent family</p>
---	---

Date of the actual completion of the international search  11 July 2019	Date of mailing of the international search report  23/07/2019
---	--

Name and mailing address of the ISA/ European Patent Office, P.B. 5818 Patentlaan 2 NL - 2280 HV Rijswijk Tel. (+31-70) 340-2040, Fax: (+31-70) 340-3016	Authorized officer  Simonini, Stefano
--	---

# INTERNATIONAL SEARCH REPORT

Information on patent family members

International application No

PCT/SI2018/000026

Patent document cited in search report		Publication date	Patent family member(s)	Publication date
JP 2016162683	A	05-09-2016	NONE	
-----				
US 2296627	A	22-09-1942	NONE	
-----				
GB 1033814	A	22-06-1966	NONE	
-----				