



(51) International Patent Classification:

A61M 39/28 (2006.01) F16K 7/00 (2006.01)

(21) International Application Number:

PCT/EP2018/072849

(22) International Filing Date:

24 August 2018 (24.08.2018)

(25) Filing Language:

English

(26) Publication Language:

English

(30) Priority Data:

17306167.2 11 September 2017 (11.09.2017) EP

(71) Applicant: **FRESENIUS VIAL SAS** [FR/FR]; Patent Department Medical Devices Division Le Grand Chemin BP 3, 38590 Brézins (FR).

(72) Inventor: **MERMET, Emeric**; 128B Avenue General Leclerc, 38950 Saint Martin Le Vinoux (FR).

(74) Agent: **KUSCHE, Robert**; Else-Kröner-Str. 1, 61352 Bad Homburg (DE).

(81) Designated States (unless otherwise indicated, for every kind of national protection available): AE, AG, AL, AM, AO, AT, AU, AZ, BA, BB, BG, BH, BN, BR, BW, BY, BZ, CA, CH, CL, CN, CO, CR, CU, CZ, DE, DJ, DK, DM, DO, DZ, EC, EE, EG, ES, FI, GB, GD, GE, GH, GM, GT, HN, HR, HU, ID, IL, IN, IR, IS, JO, JP, KE, KG, KH, KN, KP,

KR, KW, KZ, LA, LC, LK, LR, LS, LU, LY, MA, MD, ME, MG, MK, MN, MW, MX, MY, MZ, NA, NG, NI, NO, NZ, OM, PA, PE, PG, PH, PL, PT, QA, RO, RS, RU, RW, SA, SC, SD, SE, SG, SK, SL, SM, ST, SV, SY, TH, TJ, TM, TN, TR, TT, TZ, UA, UG, US, UZ, VC, VN, ZA, ZM, ZW.

(84) Designated States (unless otherwise indicated, for every kind of regional protection available): ARIPO (BW, GH, GM, KE, LR, LS, MW, MZ, NA, RW, SD, SL, ST, SZ, TZ, UG, ZM, ZW), Eurasian (AM, AZ, BY, KG, KZ, RU, TJ, TM), European (AL, AT, BE, BG, CH, CY, CZ, DE, DK, EE, ES, FI, FR, GB, GR, HR, HU, IE, IS, IT, LT, LU, LV, MC, MK, MT, NL, NO, PL, PT, RO, RS, SE, SI, SK, SM, TR), OAPI (BF, BJ, CF, CG, CI, CM, GA, GN, GQ, GW, KM, ML, MR, NE, SN, TD, TG).

Published:

— with international search report (Art. 21(3))

(54) Title: PINCH CLAMP DEVICE

FIG 2

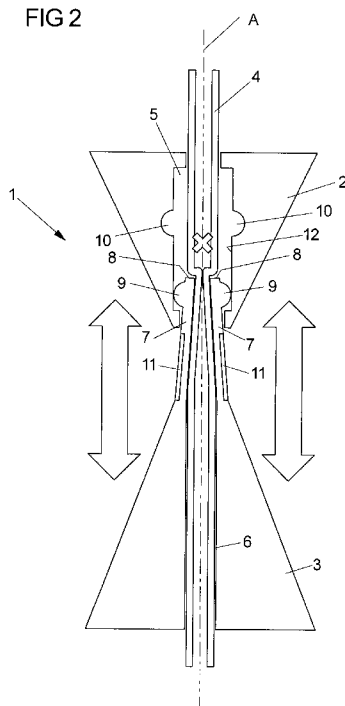

(57) Abstract: A pinch clamp device for a flexible tube is disclosed, the pinch clamp device comprising a first part (2) and a second part (3) that are movable with respect to each other, wherein the first part (2) comprises a first conduit (5) for housing a flexible tube and the second part (3) comprises a second conduit (6) for housing the same flexible tube, wherein the first part (2) and the second part (3) are arranged in an interacting manner such that the pinch clamp device can be present in a first position or in a second position, wherein a flow of a fluid within a flexible tube arranged inside the first conduit (5) and the second conduit (6) is enabled in the first position, and wherein a flow of a fluid within a flexible tube arranged inside the first conduit (5) and the second conduit (6) is prevented in the second position. According to an aspect of the invention, the first part (2) and the second part (3) are designed axisymmetrically. Furthermore, a pinch clamp arrangement comprising such a pinch clamp device is disclosed. Additionally pump arrangement comprising a pump and such a pinch clamp arrangement is disclosed.



---

**Pinch clamp device**

---

**5 Description**

The present invention relates to a pinch clamp device according to the preamble of claim 1, to a pinch clamp arrangement comprising such a pinch clamp device according to the preamble of claim 11, and to a pump arrangement comprising such a pinch clamp arrangement according to the preamble of claim 12.

A so-called pump set, i.e., a combination of a flexible tube and a pinch clamp (and optionally connecting parts) is inserted into a pump device, such as a volumetric pump, in order that the pump device can pump a fluid through the tube. Thereby, the pinch clamp is intended to prevent free flow of a fluid through the flexible tube if the pump set is removed from the pump device or if the pump device is opened.

US 2010/0268161 A1 discloses a clamp for a flexible tube that is intended to be inserted into a pump device. However, there is only one geometric arrangement (one specific angle) in which the disclosed clamp can be inserted into the pump device. This complicates installing of the clamp (or a pump set equipped therewith) into the pump device and results in extended handling times for healthcare professionals.

It is an object of the present invention to provide a pinch clamp that can be more intuitively handled than pinch clamps known from prior art.

This object is achieved with a pinch clamp device for a flexible tube having the claim elements of claim 1. Such a pinch clamp device comprises a first part and a second part. Both parts are movable with respect to each other. Thereby, the first part comprises a first conduit for housing a flexible tube. Likewise, the second part comprises a second conduit for housing the same flexible tube. The first part and the second part interact with each other. Specifically, depending on the relative position of the first part and the second part, the pinch clamp device can be present in a first position or in a second position. Thereby, a flow of fluid within a flexible tube arranged inside the first conduit and inside the second conduit is enabled in the first position. Contrary, a flow of fluid within a flexible tube arranged inside the first conduit and inside the second conduit is prevented in the second position. By moving the first part and the second part relative to each other, the pinch clamp device can be

transferred from its first position to its second position, and vice versa. Thus, it is possible to open and close the pinch clamp by such a movement of the first part and the second part.

5 The first part and the second part of the claimed pinch clamp device are designed axisymmetrically. In doing so, it is not necessary to install the pinch clamp device in a specific geometric arrangement or in a specific angle into a pump device. Rather, any orientation of the pinch clamp device is likewise suited for the pinch clamp device to be installed into a pump. Thus, the user of the pinch clamp device needs no longer to look for the "correct" orientation of the pinch clamp so that it can be installed into a corresponding  
10 pump device. Rather, the user can simply install the pinch clamp device in the orientation in which he or she currently holds it in his or her hands. Therewith, the use of the pinch clamp device according to an aspect of the instant invention is much more intuitive than the use of a pinch clamp device known from prior art. Furthermore, the handling time for installing a pump set comprising a corresponding pinch clamp device is significantly reduced compared to the  
15 handling time of pinch clamp devices known from prior art. This saved time can be used by healthcare professionals for patient care itself.

In an embodiment, a symmetry axis of the first part extends along the first conduit. Alternatively or additionally, a symmetry axis of the second part extends along the second  
20 conduit. Thus, in this embodiment, the first conduit is located in the symmetry center of the first part, and/or the second conduit is located in the symmetry center of the second part. In an embodiment, the first part and the second part share the same symmetry axis. If both conduits are located in the symmetry center of the respective part, a flexible tube is guided through the first conduit and the second conduit always in the same position, irrespective of  
25 the specific geometric arrangement of the first part and the second part. This makes an installation of a pump set comprising a corresponding pinch clamp device particularly simple.

It should be noted that the pinch clamp needs not be necessarily used together with a pump. Rather, it is suited to be used for clamping any kind of conduit. E.g., it can also be used for  
30 clamping a conduit through which a fluid flows by gravity in order to stop the fluid flow as desired.

In an embodiment, the first part and the second part are movable with respect to each other by a translational movement of at least one of the parts. Thus, it is possible to move either  
35 the first part or the second part, or both the first part and the second part in a translational manner. In other embodiments, a rotational movement or a combination of a rotational

movement and a translational movement (e.g., a helical movement along a helical guiding) are also possible.

5 In an embodiment, the second part can be moved along an extension direction of the first conduit. In a particular appropriate variant of this embodiment, the first conduit and the second conduit are arranged coaxially to each other.

10 In an embodiment, the first part and the second part are individual components that interact with each other but could be generally separated. This facilitates the manufacturing of the pinch clamp device. However, in an embodiment, the first part and the second part act cooperate with each other, wherein they cannot be separated from each other when exerting forces that are applied during normal use of the pinch clamp device. Thus, only upon exerting forces exceeding the forces applied during intended use of the pinch clamp device, the first part could be separated from the second part.

15

In an embodiment, the second part is nested within the first part. E.g., it is possible that the second part can be inserted into the first part and at least partly withdrawn from the first part in a telescopic manner. Such an arrangement makes an application of the pinch clamp device particularly simple.

20

In an embodiment, the second part comprises a flexible extension extending along the second conduit. Thereby, the flexible extension can be present in a relaxed position or in a compressed position. If the flexible extension is in its relaxed position, then the pinch clamp device is in its first position. If the flexible extension is in its compressed position, the pinch clamp device is in its second position. In an embodiment, the flexible extension is that part of the second part that can be inserted into the first part and that can be partly withdrawn from the first part. In an embodiment, the flexible extension is in its relaxed state if the second part is fully inserted into the first part. Then, the flexible extension is in its compressed position if the second part is partly withdrawn from the first part up to its maximum withdrawn position with respect to the first part.

30

In an embodiment, the flexible extension has a free end and comprises a protrusion on the free end. Thereby, this protrusion extends readily away from the second conduit. This protrusion is received in a recess in the first part if the flexible extension is in its relaxed position (e.g., if the second part is fully inserted into the first part). Likewise, if the flexible extension is in its compressed position, the protrusion abuts an inner wall of the first conduit

35

(e.g., if the second part is at least partly withdrawn from the first part, but is still partly nested within the first part).

5 In an embodiment, the second part comprises a mark that is only visible for a user of the pinch clamp device if the pinch clamp device is in its second position. Such a mark facilitates a recognition whether or not the pinch clamp device is in its first (open) or second (closed) position. The marker can, e.g., be realized by a color coding. If a user of the pinch clamp device sees the color coding or any other kind of marker, he or she will immediately know that the pinch clamp device is in its second (closed) position so that no free flow of a fluid  
10 being present within a flexible tube that is received by the pinch clamp device is possible. At the same time, the user will immediately know that he or she will have to transfer the pinch clamp device into its first (open) position in order to allow a flow of fluid through a flexible tube being received within the pinch clamp device. Thus, for proper operation of a pump device in which the pinch clamp device is installed, the marker has to disappear from the  
15 visual field of the user. Expressed in other words, the marker, e.g. a color coding, allows a visual identification of the open or closed state of the pinch clamp device.

In an embodiment, the first part and the second part have a different outer design or geometry. Then, it is particularly easy for a user to install the pinch clamp device or a pump  
20 set including such a pinch clamp device in the correct upstream/downstream orientation within a pump. This additional aid for a user to correctly install the pinch clamp device within a pump device makes particularly sense if a corresponding pump set has a defined inflow and outflow orientation of a fluid to be transported through the pump set. Pump sets usually exhibit such an orientation. The outer design of the first part and the second part can be  
25 chosen such that it is immediately apparent for a user which part of the pinch clamp device is to be inserted into the corresponding recess in a pump device. Since the first part and the second part are designed axisymmetrically, the specific orientation of the first part and the second part does not matter for correct installation if both parts are orientated to the correct direction for the installation of the pinch clamp device.

30 In an aspect, the present invention relates to a pinch clamp arrangement comprising a pinch clamp device according to the preceding explanations as well as a flexible tube. Thereby, the pinch clamp device comprises a first part and a second part. Both parts are movable with respect to each other. The first part comprises a first conduit that houses a section of the  
35 flexible tube. The second part comprises a second conduit that also houses a section of the flexible tube. Thereby, the first part and the second part are arranged in interacting manner so that the pinch clamp device can be present in a first position or in a second position. If it is

in the first position, flow of fluid within the flexible tube is enabled. If the device is in its second position, a flow of fluid within the flexible tube is prevented. To allow an easy and intuitive installation of the pinch clamp device of the pinch clamp arrangement, the first part and the second part are designed axisymmetrically.

5

The pinch clamp arrangement can also be referred to as pump set, in particular if it additionally comprises connecting elements at the respective ends of the flexible tube.

10

In an aspect, the present invention also relates to a pump arrangement comprising a pump device and a pinch clamp arrangement according to the preceding explanations, wherein the pinch clamp arrangement is installed into the pump.

15

In an embodiment, the pump device comprises a cover that can be opened to install the pinch clamp arrangement within the pump or to remove it therefore. Thereby, the pinch clamp device is automatically transferred from its first position into its second position if the cover of the pump device is opened or if the pinch clamp arrangement is removed from the pump device. This automatic transfer can be realized by a lever being activated by said cover and interacting with the pinch clamp arrangement such that it causes a movement of the second part relative to the first part of the pinch clamp device.

20

In an embodiment, the pump is a volumetric pump, e.g., a perfusion pump that can be used to administer a pharmaceutical composition or a nutritional composition to a person in need thereof.

25

In an aspect, the present invention relates to a method for administering a pharmaceutical composition or a nutritional composition to person in need thereof by inserting a pinch clamp arrangement according to the preceding explanations into a pump device, connecting a first end of the flexible tube of the pinch clamp arrangement to a reservoir of a pharmaceutical composition or a nutritional composition, and connecting a second end of the flexible tube to

30

a cannula or feeding tube which is then used to administer the pharmaceutical composition or the nutritional composition to a person in need thereof.

35

All embodiments described in the preceding sections with respect to the pinch clamp device can be combined in any desired manner and can be transferred to the described pinch clamp arrangement, the described pump arrangement, and the described method, and vice versa.

Further details of aspects of the present invention will be explained with respect to exemplary embodiment and accompanying Figures. In the Figures:

5 Figure 1 shows a cross-sectional view of an embodiment of a pinch clamp device in a first (open) position; and

Figure 2 shows a cross-sectional view of the pinch clamp device of Figure 1 in its second (closed) position.

10 Figure 1 shows a pinch clamp arrangement 1 that comprises a first part 2, a second part 3 and a flexible tube for extending through the first part 2 and the second part 3. The first part 2 and the second part 3 have a cone-like outer geometry. They are designed axisymmetrically with respect to a symmetry axis A extending along the center of a first conduit 5 and a  
15 the second conduit 6. Thereby, the first conduit 5 is arranged in the center of the first part 2, and the second conduit 6 is arranged in the center of the second part 3.

A flexible tube 4 is guided through the first conduit 5 and the second conduit 6 so as to be encompassed by the first part 2 and the second part 3 of the pinch clamp arrangement 1.

20 The second part 3 comprises – besides its conical body – two flexible fingers 7 that serve as flexible extension. These flexible fingers 7 extend away from the conical body along the second conduit 6. The flexible fingers 7 can be moved in a radial direction, i.e., towards the symmetry axis A.

25 The flexible fingers have a free end 8 and a protrusion 9 that is arranged near the flexible end 8. This protrusion is housed in a recess 10 of the first part 2 of the pinch clamp arrangement 1. Thereby, the recess 10 is dimensioned such that the protrusion 9 of each flexible finger 7 can be housed in the recess 10 without bending the flexible finger 7 towards  
30 the symmetry axis A.

35 On an outer circumference of the flexible fingers 7, a color coding 11 serving as a mark is arranged. This color coding 11 is invisible if the pinch clamp arrangement 1 is in its first position illustrated in Figure 1 since the second part 3 is, in this position, inserted into the first part 2 to such an extent that the color coding 11 is fully received within the interior of the first part 2.

Since the flexible fingers 7 are not bent towards the symmetry axis A, the cross-section of the flexible tube 4 is not altered within the first conduit 5 and the second conduit 6 so that any fluid flowing through the flexible tube 4 can freely pass the first part 2 and the second part 3 of the pinch clamp arrangement 1. This is illustrated by corresponding arrows along the symmetry axis A.

Figure 2 shows the pinch clamp arrangement 1 of Figure 1 in its second (closed) position. The same elements are marked with the same numeral references as in Figure 1. In this second position, the second part 3 is partly withdrawn from the first part 1 (although it still interacts with the first part 2). Due to this partial withdrawal, the protrusions 9 are no longer received by the recesses 10. Rather, the protrusions 9 abut an inner wall 12 of the first conduit 5. Due to this, the flexible fingers 7 are bent towards the symmetry axis A. As a consequence, the flexible fingers 7 press against the flexible tube 4 and prevent flow of fluid within the flexible tube 4. Thus, in this position, the pinch clamp arrangement 1 securely prevents any free flow of fluid through the flexible tube 4.

Since the second part 3 is partly withdrawn from the first part 2 in the direction indicated by big arrows at the side of the first part 2 and the second part 3, the color coding 11 becomes visible for a user. Thus, the user can see at a glance that the pinch clamp arrangement 1 is in its closed position and does not allow any fluid flowing through the flexible tube 4. If the user intends to enable a fluid flow, he or she has to move the first part 2 and the second part 3 in the direction of the arrows indicated in Figure 1 at the side of the first part 2 and the second part 3.

\* \* \* \* \*

25



**Claims**

1. Pinch clamp device for a flexible tube, comprising a first part (2) and a second part (3) that are movable with respect to each other, wherein the first part (2) comprises a first  
5 conduit (5) for housing a flexible tube and the second part (3) comprises a second conduit (6) for housing the same flexible tube, wherein the first part (2) and the second part (3) are arranged in an interacting manner such that the pinch clamp device can be present in a first position or in a second position, wherein a flow of a fluid within a flexible tube arranged inside the first conduit (5) and the second conduit (6) is enabled in the first  
10 position, and wherein a flow of a fluid within a flexible tube arranged inside the first conduit (5) and the second conduit (6) is prevented in the second position,
- characterized**
- 15 in that the first part (2) and the second part (3) are designed axisymmetrically.
2. Pinch clamp device according to claim 1, **characterized** in that a symmetry axis (A) of the first part (2) extends along the first conduit (5) and/or in that a symmetry axis (A) of the second part (3) extends along the second conduit (6).  
20
3. Pinch clamp device according to claim 1 or 2, **characterized** in that the first part (2) and the second part (3) are movable with respect to each other by a translational movement of at least one of the first part (2) and the second part (3).
- 25 4. Pinch clamp device according to any of the preceding claims, **characterized** in that the second part (3) can be moved along an extension direction of the first conduit (5).
5. Pinch clamp device according to any of the preceding claims, **characterized** in that the first part (2) and the second part (3) are individual components.  
30
6. Pinch clamp device according to any of the preceding claims, **characterized** in that the second part (3) is nested within the first part (2).
7. Pinch clamp device according to any of the preceding claims, **characterized** in that the  
35 second part (3) comprises a flexible extension (7) extending along the second conduit (6), wherein the flexible extension (7) can be present in a relaxed position or in a compressed position, wherein the pinch clamp device is in the first position if the flexible

extension (7) is in its relaxed position, and wherein the pinch clamp device is in the second position if the flexible extension (7) is in its compressed position.

8. Pinch clamp device according to claim 7, **characterized** in that the flexible extension (7) has a free end (8) and comprises a protrusion (9) on the free end (8), wherein the protrusion (9) extends radially away from the second conduit (6), wherein the protrusion (9) is received in a recess (10) in the first part (2) if the flexible extension (7) is in its relaxed position and abuts an inner wall (12) of the first conduit (5) if the flexible extension (7) is in its compressed position.
9. Pinch clamp device according to claim 7 or 8, **characterized** in that the second part (3) comprises a mark (11) that is only visible for a user of the pinch clamp device if the pinch clamp device is in its second position.
10. Pinch clamp device according to any of the preceding claims, **characterized** in that the first part (2) and the second part (3) have a different outer design.
11. Pinch clamp arrangement comprising a pinch clamp device according to any of the preceding claims and a flexible tube (4), wherein the pinch clamp device comprises a first part (2) and a second part (3) that are movable with respect to each other, wherein the first part (2) comprises a first conduit (5) that houses a section of the flexible tube (4), wherein the second part (3) comprises a second conduit (6) that houses a section of the flexible tube (4), wherein the first part (2) and the second part (3) are arranged in an interacting manner such that the pinch clamp device can be present in a first position or in a second position, wherein a flow of a fluid within the flexible tube (4) is enabled in the first position, and wherein a flow of a fluid within the flexible tube (4) is prevented in the second position,
- characterized**
- in that the first part (2) and the second part (3) are designed axisymmetrically.
12. Pump arrangement comprising a pump and a pinch clamp arrangement (1) according to claim 11 that is installed into the pump.
13. Pump arrangement according to claim 12, **characterized** in that the pump comprises a cover that can be open to install the pinch clamp arrangement (1) within the pump or to

remove it therefrom, wherein the pump comprises means for automatically transferring the pinch clamp device of the pinch clamp arrangement (1) from its first position into its second position if the cover of the pump is opened or if the pinch clamp arrangement is removed from the pump.

5

14. Pump arrangement according to claim 12 or 13, **characterized** in that the pump is a volumetric pump, in particular a perfusion pump.

\* \* \* \* \*

10

FIG 1

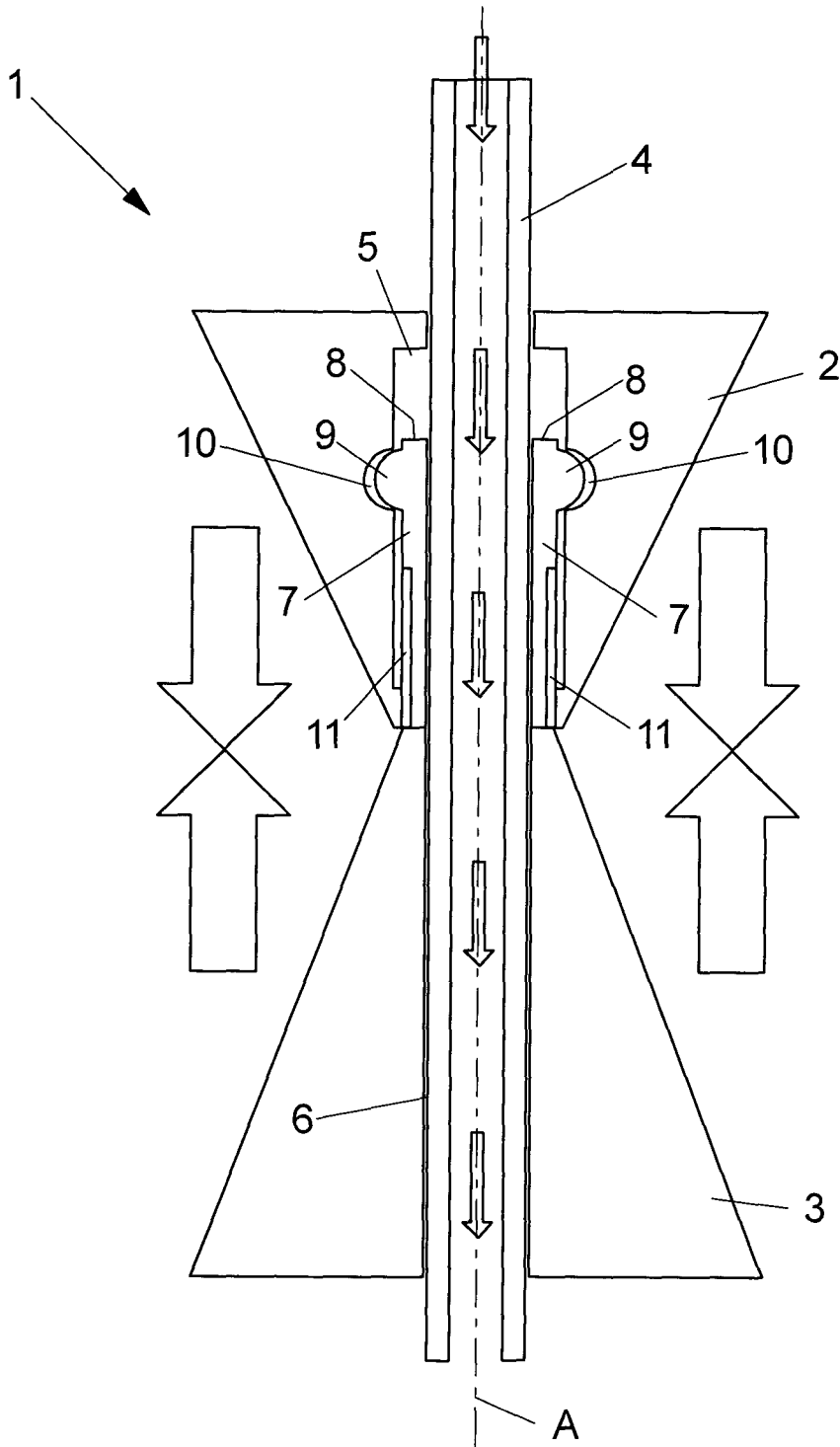
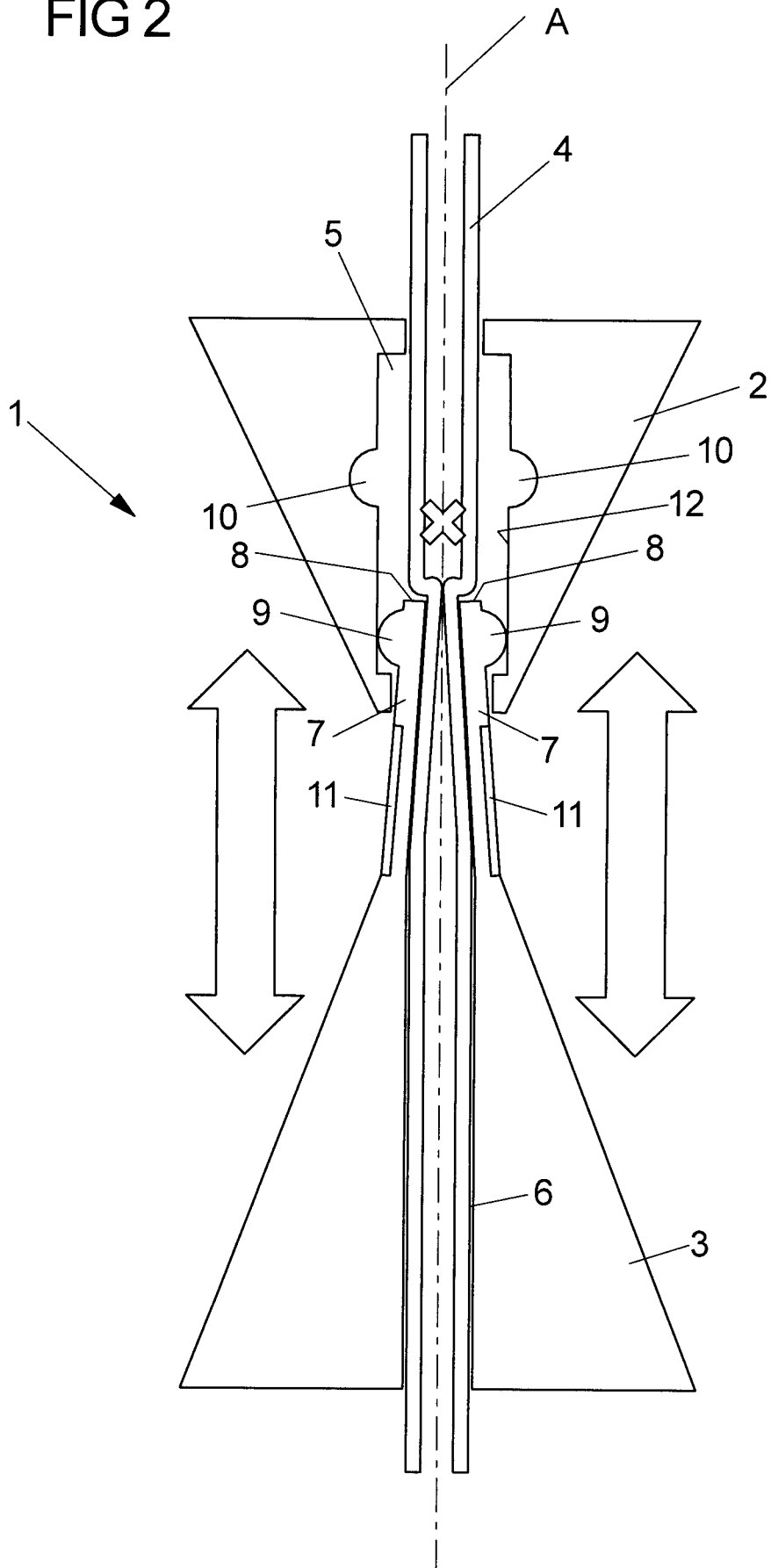

FIG 2



INTERNATIONAL SEARCH REPORT

International application No  
PCT/EP2018/072849

A. CLASSIFICATION OF SUBJECT MATTER  
INV. A61M39/28 F16K7/00  
ADD.  
According to International Patent Classification (IPC) or to both national classification and IPC

B. FIELDS SEARCHED  
Minimum documentation searched (classification system followed by classification symbols)  
A61M F16K

Documentation searched other than minimum documentation to the extent that such documents are included in the fields searched

Electronic data base consulted during the international search (name of data base and, where practicable, search terms used)  
EPO-Internal, WPI Data

C. DOCUMENTS CONSIDERED TO BE RELEVANT

Category*	Citation of document, with indication, where appropriate, of the relevant passages	Relevant to claim No.
X	US 5 810 323 A (WINTERER SEAN [US] ET AL) 22 September 1998 (1998-09-22) figures 3A, 3B -----	1-14
X	US 2 858 095 A (HARRIS EDWARD P ET AL) 28 October 1958 (1958-10-28) figures 1-5 -----	1-14
X	WO 2010/101783 A2 (DEKA PRODUCTS LP [US]; KAMEN DEAN [US]; KENLEY RODNEY S [US]; VIOLETTE) 10 September 2010 (2010-09-10) figures 4,5 -----	1-14
X	GB 2 448 374 A (HOWARD PETER LYNTON [GB]) 15 October 2008 (2008-10-15) figures 9,10 -----	1-14
	----- -/--	

Further documents are listed in the continuation of Box C.

See patent family annex.

\* Special categories of cited documents :

- "A" document defining the general state of the art which is not considered to be of particular relevance
- "E" earlier application or patent but published on or after the international filing date
- "L" document which may throw doubts on priority claim(s) or which is cited to establish the publication date of another citation or other special reason (as specified)
- "O" document referring to an oral disclosure, use, exhibition or other means
- "P" document published prior to the international filing date but later than the priority date claimed

- "T" later document published after the international filing date or priority date and not in conflict with the application but cited to understand the principle or theory underlying the invention
- "X" document of particular relevance; the claimed invention cannot be considered novel or cannot be considered to involve an inventive step when the document is taken alone
- "Y" document of particular relevance; the claimed invention cannot be considered to involve an inventive step when the document is combined with one or more other such documents, such combination being obvious to a person skilled in the art
- "&" document member of the same patent family

Date of the actual completion of the international search  14 September 2018	Date of mailing of the international search report  28/09/2018
Name and mailing address of the ISA/ European Patent Office, P.B. 5818 Patentlaan 2 NL - 2280 HV Rijswijk Tel. (+31-70) 340-2040, Fax: (+31-70) 340-3016	Authorized officer  Krassow, Heiko

# INTERNATIONAL SEARCH REPORT

International application No  
PCT/EP2018/072849

C(Continuation). DOCUMENTS CONSIDERED TO BE RELEVANT		
Category*	Citation of document, with indication, where appropriate, of the relevant passages	Relevant to claim No.
A	EP 1 466 646 A1 (NUTRICIA HEALTHCARE S A [CH]) 13 October 2004 (2004-10-13) figures 3,4 -----	1-14

# INTERNATIONAL SEARCH REPORT

Information on patent family members

International application No PCT/EP2018/072849
---

Patent document cited in search report	Publication date	Patent family member(s)	Publication date
US 5810323	A	22-09-1998	NONE
		AT 229829 T	15-01-2003
		AU 5527596 A	16-10-1996
		DE 69625521 D1	30-01-2003
		DE 69625521 T2	02-10-2003
		EP 0900106 A1	10-03-1999
		ES 2187647 T3	16-06-2003
		JP H11509744 A	31-08-1999
		US 5704584 A	06-01-1998
		US 5810323 A	22-09-1998
		WO 9630679 A1	03-10-1996
US 2858095	A	28-10-1958	NONE
WO 2010101783	A2	10-09-2010	NONE
		EP 2405968 A2	18-01-2012
		JP 5681644 B2	11-03-2015
		JP 2012519544 A	30-08-2012
		US 2010234809 A1	16-09-2010
		US 2015151105 A1	04-06-2015
		WO 2010101783 A2	10-09-2010
GB 2448374	A	15-10-2008	NONE
		EP 2148720 A1	03-02-2010
		GB 2448374 A	15-10-2008
		US 2010056976 A1	04-03-2010
		WO 2008125838 A1	23-10-2008
EP 1466646	A1	13-10-2004	NONE