

(12) INTERNATIONAL APPLICATION PUBLISHED UNDER THE PATENT COOPERATION TREATY (PCT)

(19) World Intellectual Property
Organization

International Bureau

(43) International Publication Date
07 March 2019 (07.03.2019)



(10) International Publication Number
WO 2019/043400 A1

(51) International Patent Classification:
B63B 39/06 (2006.01)

TR), OAPI (BF, BJ, CF, CG, CI, CM, GA, GN, GQ, GW,
KM, ML, MR, NE, SN, TD, TG).

(21) International Application Number:
PCT/GB2018/052465

Published:
— with international search report (Art. 21(3))

(22) International Filing Date:
31 August 2018 (31.08.2018)

(25) Filing Language: English

(26) Publication Language: English

(30) Priority Data:
1714058.3 01 September 2017 (01.09.2017) GB

(71) Applicant: **SLLP 134 LIMITED** [GB/GB]; 28 Albyn
Place, Aberdeen Aberdeenshire AB10 1YL (GB).

(72) Inventor: **BOWIE, Malcolm**; SLLP 134 Limited, 28 Al-
byn Place, Aberdeen Aberdeenshire AB10 1YL (GB).

(74) Agent: **IPENTUS LIMITED**; The Old Manse, Wilson-
town, By Forth, Lanark Strathclyde ML11 8EP (GB).

(81) Designated States (unless otherwise indicated, for every
kind of national protection available): AE, AG, AL, AM,
AO, AT, AU, AZ, BA, BB, BG, BH, BN, BR, BW, BY, BZ,
CA, CH, CL, CN, CO, CR, CU, CZ, DE, DJ, DK, DM, DO,
DZ, EC, EE, EG, ES, FI, GB, GD, GE, GH, GM, GT, HN,
HR, HU, ID, IL, IN, IR, IS, JO, JP, KE, KG, KH, KN, KP,
KR, KW, KZ, LA, LC, LK, LR, LS, LU, LY, MA, MD, ME,
MG, MK, MN, MW, MX, MY, MZ, NA, NG, NI, NO, NZ,
OM, PA, PE, PG, PH, PL, PT, QA, RO, RS, RU, RW, SA,
SC, SD, SE, SG, SK, SL, SM, ST, SV, SY, TH, TJ, TM, TN,
TR, TT, TZ, UA, UG, US, UZ, VC, VN, ZA, ZM, ZW.

(84) Designated States (unless otherwise indicated, for every
kind of regional protection available): ARIPO (BW, GH,
GM, KE, LR, LS, MW, MZ, NA, RW, SD, SL, ST, SZ, TZ,
UG, ZM, ZW), Eurasian (AM, AZ, BY, KG, KZ, RU, TJ,
TM), European (AL, AT, BE, BG, CH, CY, CZ, DE, DK,
EE, ES, FI, FR, GB, GR, HR, HU, IE, IS, IT, LT, LU, LV,
MC, MK, MT, NL, NO, PL, PT, RO, RS, SE, SI, SK, SM,

(54) Title: SYSTEM FOR PROVIDING STABILITY TO A FLOATING OFFSHORE STRUCTURE

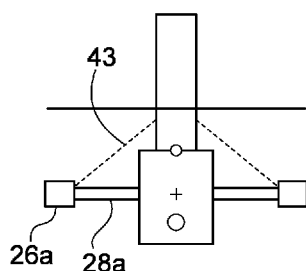

Fig. 1d

(57) Abstract: A system for improving the static and dynamic stability of an offshore floating structure in which outriggers having a unit with an inertial mass are supported from the structure to hold each unit at a radial distance from a centre of rotation of the offshore floating structure and be entirely submerged. Water may enter and exit a tank in a unit to statically adjust and dynamically control stability and dampen roll and pitch of the structure. The outriggers can be raised for tow. The outriggers ballast can be adjusted during tow, installation and in operation. The units can transport mooring lines. An embodiment of a hydrocarbon production or support facility is described with the dynamic flexible risers connected to a support structure of the system.

WO 2019/043400 A1

SYSTEM FOR PROVIDING STABILITY TO A FLOATING OFFSHORE STRUCTURE

The present invention relates to stabilising floating offshore structures and in particular, though not exclusively, to system for providing static and dynamic stability of an offshore floating structure for use at an offshore oilfield development.

The development of oilfields has relied on floating production and storage systems, especially in deep water. These facilities are often ship based, however there are a number of semi-submersible, spar shaped and large diameter cylindrical shaped facilities. They are all considered as floating offshore structures even though they are, to some extent, connected to the bottom of the sea as required for the operations, the structures are maintained above the water level by flotation and buoyancy.

In order to operate from a floating offshore structure, the structure must be moored in a location and be stable. Stability generally takes two forms. One is static stability where the position of the centre of gravity and the centre of buoyancy have a key role in the angle a floating structure will take. In addition the free-surface effect also dictates the stability of a structure. Static stability is designed into the structure based on the structure sitting in a static body of water. However, floating offshore structures are located at sea and thus the structure will follow motions of the surface of the sea. The second form of stability is dynamic stability, where the static stability is acceptable; however, the natural period in roll or pitch of the structure is one which coincides with the period of the waves. The resultant is a resonant response which leads to large roll or pitch angles.

Semi-submersible facilities have three or more columns which pass through the water line and provide static stability via the free-surface effect and the subsequent righting moment from immersion of one column. The semi-submersible facilities attract wave loading on all columns and hence the structural design of the bracing between each column needs to have sufficient redundancy.

The spar design is a single tall cylinder, which is stable due to the large distance between the centre of buoyancy and the centre of gravity. This is a more unitary structure; however, the spar requires deep water to operate in plus the fabrication, load-out and installation needs suitable geographic location and facilities. The ratio of overall height to diameter is typically in the region of 3 to 10.

There is also a floating production design which consists of a large diameter cylinder, which is partly submerged. This is a unitary structure which relies on the very large diameter to give a high righting moment and hence stability. Due to the large projected area the wave loads on the structure are very high. The ratio of overall height to diameter is typically in the region of 0.5 to 1.

There is another facility consisting of an unmanned submerged buoy, which differs from all of the previous in that the majority or all of the equipment is completely under the water. The majority of the displaced volume is well underneath the sea surface, but only a single column smaller diameter column pierces the sea surface. There is therefore a low free-surface effect and hence restoring force.

In these structures, the centre of gravity and the centre of buoyancy have to be carefully adjusted to maintain static stability;

however the natural period of pitch/roll of such a structure is critical to its dynamic response in waves. The natural period of oscillation in the pitch/roll directions should be outside the range of typical waves periods observed offshore to avoid resonant response. These
5 wave periods to avoid are typically in the region of 3 seconds to 25 seconds.

To increase the natural period of oscillation of the structure the mass of the structure should be distributed as far apart as practical
10 to increase the rotational moment of inertia. This can be difficult to achieve without increasing the height of the centre of gravity and thus reducing the static stability.

US 3,568,620 discloses a roll and/or pitch suppressor for floating
15 marine structures in which pairs of buckets are suspended from outriggers symmetrically arranged in relation to a roll or pitch axis. The buckets of a pair fill during downstroke and empty during up stroke in phase opposition to provide roll or pitch suppressing or damping momentum.

20

In this arrangement two or four buckets are arranged across the roll and/or pitch axis. The initial position is based on being in static water and the buckets are partially submerged. This means that the floating structure must be designed to have its centre of rotation to
25 be on the water line. As the centre of rotation sits between the centre of buoyancy and centre of gravity, this limits the design of the floating structure to provide sufficient static stability.

It is therefore an object of the present invention to provide an
30 apparatus and method to give improved static and dynamic stability of an offshore floating structure which obviates or mitigates at least some of the disadvantages of the prior art.

According to the present invention there is provided a system for improving the static and dynamic stability of an offshore floating structure comprising:

- 5 a plurality of outriggers, each outrigger having a unit, the unit having an inertial mass; and
a support structure, the support structure locatable to the offshore floating structure and holding the units at a radial distance from a centre of rotation of the offshore floating structure;
- 10 characterised in that:
the plurality of units are entirely submerged in use.

In this way, increased dynamic stability is achieved by positioning additional masses a horizontal distance either side of the centre of rotation of the structure. The centre of rotation of the structure may not necessarily be the same as the centre of gravity due to its hydrodynamic profile. These additional masses increase the rotational inertia of the structure and thus increase the natural period of oscillation in the pitch / roll direction; however, they do not significantly affect the centre of gravity of the structure. Thus the floating offshore structure can be designed to have increased static stability with the centre of rotation lying below the centre of buoyancy and above the centre of gravity. Additionally, by not breaking the water line, the system itself is not affected by the motion of riding the wave.

Preferably, the inertial mass is a fixed mass. More preferably, the unit includes a weight to provide the fixed mass. The weight may be one or more materials selected from a group comprising: steel, concrete, sand, gravel and water.

In this way, the inertial mass can be selected for the design of the offshore floating structure in use. Thus any offshore floating structure can be used and does not have to be modified for use with the system of the present invention.

5

Preferably, the inertial mass includes a variable mass. In this way, the unit can have a fixed mass and a variable mass. More preferably, the unit includes a filler tank and the variable mass is provided by water entering and exiting the filler tank. In this way, the inertial mass can be varied in use. The inertial mass can therefore be dynamically controlled in use.

10

The filler tank includes one or more ports or valves to control the entry and exit of water to and from the unit. In this way, the inertial mass is dynamically controlled and the system provides a damping effect to the motion of the offshore floating structure.

15

There may be a ballast tank in a unit. The ballast tank may be sealed. In this way, air sealed in the ballast tank may control buoyancy of each outrigger and hence finely adjust the static roll/pitch angle of the offshore floating structure. Alternatively, the ballast tank may be filled with entrapped water. This adds to the fixed mass of the unit. The ballast tank may include one or more valves. In this way, the contents of the ballast tank can be varied to adjust the angle and depth of the offshore floating structure.

20
25

The units may be identical. Alternatively there may be units having differing fixed masses. In this way, the fixed mass can vary between each unit in order to compensate for the offset in the horizontal centre of gravity of the floating structure due to the layout of equipment within. There may be ballast tanks to provide a

30

variable mass in all units or only some units. In this way, the system can be tuned to suit the offshore floating structure.

Preferably, there are three outriggers. In this way, dynamic stability
5 in all planes of pitch/roll rotation rotation is achieved with the minimum number of outriggers. There may be an even number of outriggers. There may be an odd number of outriggers. More preferably, the outriggers are arranged to provide an evenly distributed mass around the offshore floating structure. The evenly
10 distributed mass may lie on a circumference. Where the units are not identical, the outriggers may not be spaced equally around a circumference. There may be up to twelve outriggers.

Preferably, the support structure comprises a plurality of support
15 arms, each arm having a first end for connection to the offshore floating structure and a second end for connection to a unit. In this way, each outrigger is independent. Alternatively, the support structure comprises a plurality of support struts wherein the support struts connect between units and to the offshore floating structure.
20 In an embodiment the support structure may comprise a continuous toroid frame in which the units are distributed within the frame on a circumference, and support arms connect the toroid frame to the offshore floating structure. More preferably, the support structure is horizontal with the units. In this way, the support structure is
25 entirely submerged in use.

Preferably, the support structure is adapted to raise and lower the outriggers. In this way, the outriggers do not touch the water surface when loading out the facility from a dry-dock. More
30 preferably, the support structure is arranged to tilt each unit to an angle greater than the horizontal. In this way, the system on an offshore floating structure can clear a restricted width passage. The

support structure may also be detachable from the floating offshore structure. In this way, the system can be arranged on the floating offshore structure once on-site or in open waters.

- 5 Preferably, the system is adapted for connection to the offshore floating structure. In this way, the system i.e. the inertial masses, or outriggers and the support structure, are not an integral part of the offshore floating structure and their removal does not fundamentally affect the integrity of the floating structure.

10

Preferably, the offshore floating structure is an offshore floating structure for use at an offshore oilfield development. The offshore floating structure may be a hydrocarbon production facility. Preferably, the support structure includes connection means for one or more dynamic flexible risers. In this way, the connection points are diver accessible. There may be a dropped object protection system arranged over the connection means.

15

20

Preferably, one or more units include a compartment, the compartment having one or more elements of a mooring line. In this way, the system is used to transport mooring line elements from the load-out location to the intended site. More preferably, an end of the mooring line is connected to the offshore floating structure. In this way, the mooring line can be removed from the compartment and used to connect the offshore floating structure to the seabed when on site, avoiding the difficult operation of having to connect the mooring lines directly onto the submerged structure. Preferably, the outriggers are used as anchoring points for a vertical tether mooring system.

25

30

Accordingly, the drawings and description are to be regarded as illustrative in nature and not as restrictive. Furthermore, the

terminology and phraseology used herein is solely used for descriptive purposes and should not be construed as limiting in scope languages such as including, comprising, having, containing or involving and variations thereof is intended to be broad and encompass the subject matter listed thereafter, equivalents and additional subject matter not recited and is not intended to exclude other additives, components, integers or steps. Likewise, the term comprising, is considered synonymous with the terms including or containing for applicable legal purposes. Any discussion of documents, acts, materials, devices, articles and the like is included in the specification solely for the purpose of providing a context for the present invention. It is not suggested or represented that any or all of these matters form part of the prior art based on a common general knowledge in the field relevant to the present invention. All numerical values in the disclosure are understood as being modified by "about". All singular forms of elements or any other components described herein are understood to include plural forms thereof and vice versa.

Embodiments of the present invention will now be described, by way of example only, with reference to the accompanying Figures, of which:

Figures 1(a)-(d) show schematic illustrations of a cross-section through an (a) offshore floating structure and the system of the present invention in (a),(d) use and in (b) transport according to an embodiment of the present invention;

Figures 2(a)-(c) show (a),(b) side views and a (c) plan view of a submerged production facility including a system with three outriggers according to an embodiment of the present invention;

Figures 3(a)-(c) show (a),(b) side views and a (c) plan view of the submerged production facility of Figure 2 including a system with three outriggers according to an alternative embodiment of the present invention;

5

Figures 4(a)-(d) show plan views of the submerged production facility of Figure 2 including a system having (a) four, (b) five, (c) six outriggers and (d) distributed outriggers in a torus, with Figure 4(e) being a side view of Figure 4(d) according to further
10 embodiments of the present invention;

Figures 5(a)-(c) show schematic illustrations of units according to embodiments of the present invention;

15 Figures 6(a) and 6(b) show connection of a dynamic riser connection to an offshore floating structure via the system according to embodiments of the present invention; and

Figure 7 shows a plan view of the offshore floating structure of
20 Figure 1 with three dynamic risers on the outriggers support structure and three mooring lines connected directly onto the offshore floating structure, according to an embodiment of the present invention.

25 Reference is initially made to Figure 1(b) of the drawings which shows an offshore floating structure 20 including a system 22 having two outriggers 24a,b according to an embodiment of the present invention. Each outrigger 24a,b has a unit 26a,b positioned a radial distance from the offshore floating structure 20 by a
30 support structure 25. Support structure 25 comprises support arms 28a,b, there being one for each unit 26a,b. Each unit 26a,b includes an inertial mass 1a,b. For clarity only two outriggers are shown

though it will be appreciated that there will be at least three. The three outriggers will typically be equally spaced.

A floating offshore structure 20, as shown in Figure 1(a), will be partly submerged in water 30 with a portion below the water line 32. In the embodiment shown, to provide static stability the structure 20 has its centre of gravity 34 below its centre of buoyancy 36. Consequently, in water subject to wave motion the structure will wish to rotate about a centre of rotation 38 between the centre of gravity 34 and the centre of buoyancy 36. This will provide a small radius of gyration 40 making the structure 20 dynamically less stable.

As shown in Figure 1(b), the present invention increases the dynamic stability of the floating structure 20 by positioning units 26 providing inertial masses 1 a distance either side of a vertical centreline through the structure 20. These masses 1 increase the rotational inertia of the overall structure and hence increase the natural period in pitch and roll. The masses 1 are entirely submerged and lie below the water line 32. In this embodiment the support structure 25 is also entirely submerged, lying below the water line 32. It is to be noted that the system 22 is an independent construction to the offshore floating structure 20 so it located around and attached to an offshore floating structure 20 when required. This also means that a suitable system 20 can be used and replaced if damaged or operating conditions change.

The inertial masses 1 can have appositive or negative mass (buoyant) in water, since they generally are not designed to alter the centre of gravity or centre of volume of the main structure.

Therefore the inertial masses 1 can be a combination of entrapped volume of water and/or combinations of ballast or air.

The inertial masses 1 also can be used to adjust the static trim of the floating structure 20 by having internal tanks in the units 26 which can be flooded or emptied of water to adjust the angle of the structure. Due to the larger lever arm 28 than ballast tanks internal to the main structure 20 less ballast fluid requires to be pumped to correct the trim of the structure 20. In this way, if the offshore floating structure 20 were a fuel supply or storage vessel, the inertial masses 1 as can be changed in individual units to counteract the change in the centre of gravity as fuel is brought on or off the offshore floating structure 20. Additionally, the inertial masses 1 can be changed i.e. increased or decreased to compensate for uneven loading of equipment on the offshore floating structure.

The ballast fluid can also be actively pumped in response to wave induced roll/pitch motions of the structure to reduce the pitch and roll motions. Thus the units 26 may fill with water which is either fully contained within a tank or able to flow in or out of an enclosed space via small holes. This space may be typically be a cylinder open at the top or bottom or a tank which has small gaps to allow movement of the water, but still retain the vast majority of the entrained water as the structure pitches or rolls. The outriggers 24 may be any geometric shape, but may typically be cylindrical.

Ideally the outriggers 24 position the inertial mass 1 as far away horizontally from the structure 20 as possible to maximise the moment of inertia; however practical considerations of the bending moment applied to the structure 20 and support structure 25 may limit this distance. If the outriggers 24 are fixed there can be an issue in the moment which has to be resisted as the structure

5 pitches and rolls. In addition to transport the structure 20 complete with the outriggers 24 attached becomes difficult due to the large dimensions of the assembly. Embodiments of the present invention have the outriggers 24 detachable or able to pivot to an angle, as shown in Figure 1(c) whereby the whole assembly can be transported much easier and fabrication of the individual items does not require to be performed at the same location.

10 The outriggers 24 can then be lowered or affixed at a convenient location using steel wires or structural arms 43, which help transfer the loads more evenly through-out the structure 20 and system 25.

15 The outriggers 24 may be designed such that they touch the water line as the structure 20 becomes free-floating (for example when flooding dry-dock) to give vertical stability. Alternatively the outriggers 24 may be positioned higher such that they clear the upper edge of dock gates when the dry-dock is fully flooded, which reduces the width of dock gates required.

20 In a preferred embodiment the offshore floating structure 20 is an offshore floating structure for use at an offshore oilfield development. The offshore floating structure may be a hydrocarbon production facility or one which provides services to enable production from a separate hydrocarbon facility 3. Such facilities may supply fuels, injection materials and/or power. They may store fuel or hydrocarbons. They may also be located over a well and act as a drilling, production or injection rig. These lists are not exhaustive.

30 Figure 2(a) illustrates a submerged production or service facility 3 and a system 122 with masses 1 at a radial distance from the centre of rotation. The masses are connected to the hull of the

production or service facility by structural braces 2 being support arms.

Figure 2(b) shows the facility 3 from a different direction and is a typical design with a main deck 4, access ladder 5, stores crane 6, telecommunications mast 7 and flare 8.

Figure 2(c) is a plan view of the same facility 3, showing three outriggers 124a,b,c spaced 120 degrees apart.

10

Figure 3(a) shows an alternative configuration of the system 222 on production facility 3 with the masses 1 supported by tubular sections in a frame configuration 2 of the support structure 225.

15 Figure 3(b) shows the facility 3 and system 222 from a different direction.

Figure 3(c) shows the facility in plan view, illustrating the typical interface of the supporting tubulars 2 with the facility hull.

20

Figure 4(a) illustrates the facility as described in the previous Figures with a system 322. System 322 has four outriggers 324a,b,c,d each providing a unit 326a-d with an inertial mass 1 connected to the structure 20 via a support arm 328a-d of the support structure 325. This provides four masses at radial distances.

25

Figure 4(b) shows the same facility as in Figure 4(a) but with five masses equally spaced. Each outrigger 424a-d has a unit 426a-e with an inertial mass. The support structure 425 now provides splayed support arms 428a-e for each outrigger 424a-e.

30

Figure 4(c) shows the same facility as in Figures 4(a) and 4(b) but with six masses equally spaced. Each outrigger 524a-f has a unit 526a-f with an inertial mass. The support structure 525 now provides tubular elements 42 arranged as tripods. There are two tripods connecting three units 526a,c,e and 526b,d,f respectively. The tripods are connected to form the support structure 525.

Figures 4(d) and 4(e) illustrate a further embodiment of a system 1022 on the same facility 3 as Figure 2(a) in elevation view and 2(c) in plan view, respectively. The support structure 25 now comprises a continuous toroid shaped structure 27 supported by four structural members 29a-d and tied back to the offshore floating structure 3. The inertial mass 1 can be evenly distributed around the circumference within the toroid or segmented into separate internal compartments to adjust the centre of gravity of the whole assembly.

Figure 5(a) shows a schematic illustration of an embodiment of a unit 626. This is one embodiment and those skilled in the art will note there are different configurations and functionality to achieve the inertial masses which are potentially available. Figure 5(a) illustrates an open central shaft 14, which may be considered as a filler tank, which will fill with water due to open ports 15 at the top and bottom; however when the facility 3 rotates the water will move with the facility giving a damping effect to its motion but without adding weight. This may be considered as a variable mass on the inertial mass to provide dynamic stability to the facility 3. The permanent weight of steel 8, acting as a fixed mass, is to keep the centre of gravity as low as practical. The addition of sand, gravel or other loose, removable and dense material 9 can be added to finely tune the masses as required post fabrication. Additional

ballast tanks 11 may be fitted to give the opportunity to adjust the trim of the structure when offshore.

Figure 5(b) shows a similar arrangement of a unit 726, except using the whole footprint of the unit to have a greater mass of steel 8 and sand/gravel 9 and with an open vent 15 at the top. Optionally additional vent ports can be added at the sides to allow free-flooding / emptying.

Figure 5(c) shows a similar arrangement of a unit 826, except the mass of steel 8 and sand/gravel 9 is higher up in the structure to match the centre of rotation of the facility 3. The lower part of the tank is a ballast tank 11, which is normally empty for load-out of the facility and is of such a height that it penetrates the water surface prior to the facility floating, thus giving a vertical stability to the whole assembly. In service the tank will be flooded with the level of ballast water controlled by opening the valves 12 and 13.

The unit 826 of Figure 5(c) provides an arrangement which also shows mooring chain 7 laid in a compartment 10 on top of the unit one end of which will typically be connected to the facility 3 on the main hull 4 with a suspended portion 5, secured temporarily to the side 6 of the unit and hung-off at the top of the unit. In field the chain 7 can be lifted out of the compartment 10 and connected to pre-installed sections of a mooring line on the seabed.

Figure 6(a) shows a dynamic flexible riser 54 and associated bending stiffener 55 being connected to a diverless bend stiffener connector 56. This bend stiffener connector is attached to a brace 2 of the support structure 25 between the unit 926 of the outrigger 924 and the main facility hull 4 of the offshore floating structure, production facility 3. The tension in the riser is taken by the end

fitting 58 which is secured to the support structure 2, inside a diver accessible recess 57. The dynamic flexible riser end fitting is connected to an angled spool 59 and then onto fixed pipework 60, which goes through the bulkhead into the facility. A dropped object protection structure 61, as is known in the art, can be placed on top for protection.

Figure 6(b) shows an alternative configuration in which the diver accessible recess 57 is replaced with a cylindrical I-tube 67, through which the end fitting 58 passes. The end fitting is hung-off at the top face of the brace 2 of support structure 25 for connection to the spool 59, which is connected to the fixed pipework 60. A dropped object panel 61 can be either installed after hook-up of the spool and riser or be a permanent fixture.

Figure 7 illustrates the layout of the same facility 3 as figure 2(c) in plan view. The spools for the dynamic flexible risers 54 are shown on one brace 2 of support structure 25. The typical mooring line 64 azimuth is illustrated with the typical connection point location onto the facility hull 4. Thus the outriggers supporting structures may be used as the interface point for supporting flexible riser terminations.

The principal advantage of the present invention is that it provides a system for improving the static and dynamic stability of an offshore floating structure which is fully submerged in use, by way of reducing the roll and pitch motions.

A further advantage of the present invention is that it provides a system for improving the static and dynamic stability of an offshore floating structure in which by allowing water to enter and exit a tank in an outrigger, the stability can be dynamically controlled with the outriggers being free-flooding and/or open.

A further advantage of the present invention is that it provides a system for improving the static and dynamic stability of an offshore floating structure in which the outriggers ballast and position can be
5 adjusted during tow, installation and in operation to compensate for changes in the horizontal centre of gravity of the floating structure, minimises the structural change required to the floating structure to centralise the horizontal centre of gravity.

10 A further advantage of the present invention is that it provides a system for improving the static and dynamic stability of an offshore floating structure in which the outriggers can be manufactured separate from the floating structure and transported separately or connected to the floating structure.

15 It will be appreciated by those skilled in the art that modifications may be made to the invention herein described without departing from the scope thereof. For example, the offshore floating structure may be an energy generating structure such as a wind turbine or
20 offshore solar panel mooring.

CLAIMS

1. A system for improving the static and dynamic stability of an offshore floating structure comprising:
5 a plurality of outriggers, each outrigger having a unit, the unit having an inertial mass; and
a support structure, the support structure locatable to the offshore floating structure and holding the units at a radial distance from a centre of rotation of the offshore floating
10 structure;
characterised in that:
the plurality of units are entirely submerged in use.
2. A system according to claim 1 wherein the inertial mass
15 includes a fixed mass.
3. A system according to claim 2 wherein the unit includes a weight to provide the fixed mass.
4. A system according to claim 3 wherein the weight is one or
20 more materials selected from a group comprising: steel, concrete, sand, gravel and water.
5. A system according to any preceding claim wherein the inertial mass includes a variable mass.
6. A system according to claim 5 wherein the unit includes a
25 filler tank and the variable mass is provided by water entering and exiting the filler tank.
7. A system according to claim 6 wherein the filler tank includes one or more ports or valves to control the entry and exit of water to and from the unit.

8. A system according to any preceding claim wherein there is a ballast tank in a unit.
9. A system according to claim 8 wherein the ballast tank is sealed.
- 5 10. A system according to claim 8 wherein the ballast tank includes one or more valves.
11. A system according to any preceding claim wherein the units are identical.
12. A system according any preceding claim wherein there are at
10 least three outriggers.
13. A system according to any preceding claim wherein there are an even number of outriggers.
14. A system according to any preceding claim wherein there are an odd number of outriggers.
- 15 15. A system according to any preceding claim wherein the outriggers are arranged to provide an evenly distributed mass around the offshore floating structure.
16. A system according to claim 15 wherein the evenly distributed mass lies on a circumference.
- 20 17. A system according to any preceding claim wherein the support structure comprises a plurality of support arms, each arm having a first end for connection to the offshore floating structure and a second end for connection to a unit.
18. A system according to any one of claims 1 to 16 wherein the
25 support structure comprises a plurality of support struts wherein the support struts connect between units and to the offshore floating structure.

19. A system according to any preceding claim wherein the support structure is horizontal with the units.
20. A system according to any preceding claim wherein the support structure is adapted to raise and lower the outriggers.
- 5 21. A system according to claim 20 wherein the support structure is arranged to tilt each unit to an angle to the horizontal.
22. A system according to any preceding claim wherein the support structure is detachable from the floating offshore structure.
- 10 23. A system according to any preceding claim wherein the offshore floating structure is an offshore hydrocarbon production or supporting facility.
24. A system according to claim 23 wherein the support structure includes connection means for one or more dynamic flexible
15 risers.
25. A system according to claim 24 wherein there is a dropped object protection system arranged over the connection means.
26. A system according to any preceding claim wherein one or
20 more units include a compartment, the compartment having one or more elements of a mooring line and an end of the mooring line is connected to the offshore floating structure.
27. A system according to any preceding claim wherein the system includes a vertical tether mooring system and the
25 outriggers are anchoring points for the vertical tether mooring system.

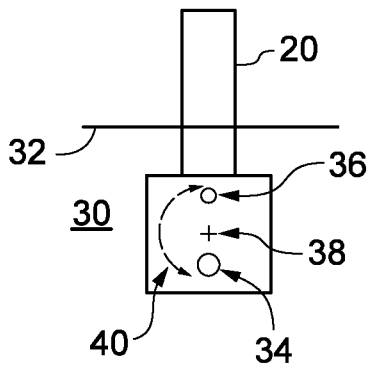

Fig. 1a

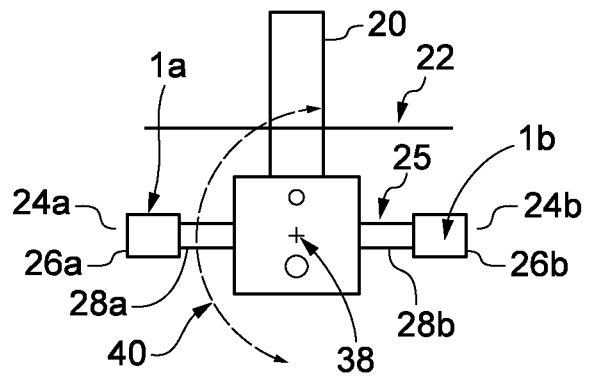

Fig. 1b

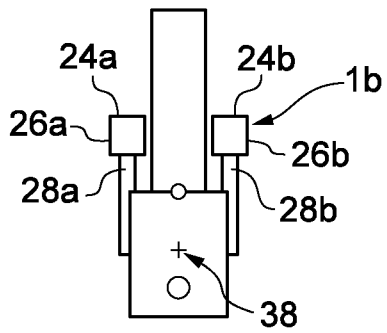

Fig. 1c

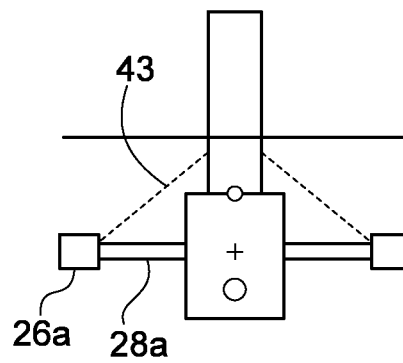

Fig. 1d

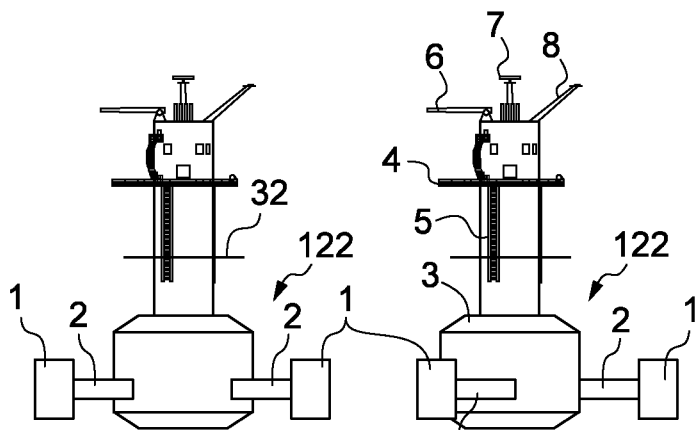

Fig. 2a

Fig. 2b

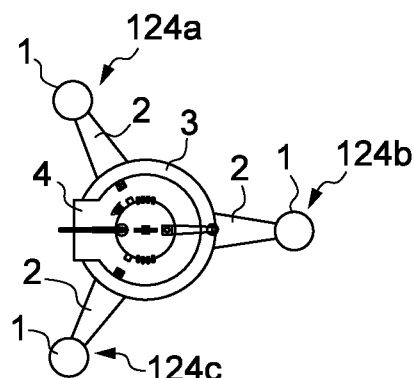

Fig. 2c

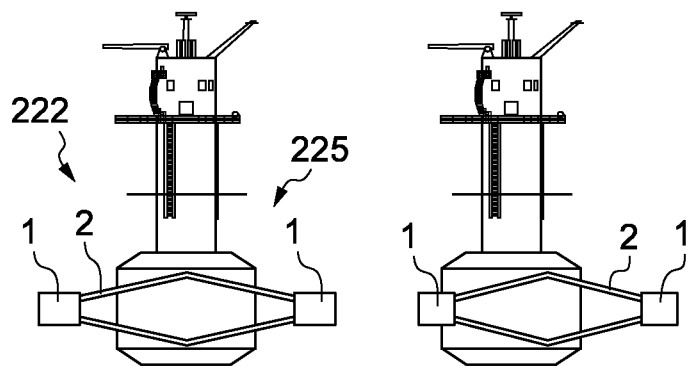

Fig. 3a

Fig. 3b

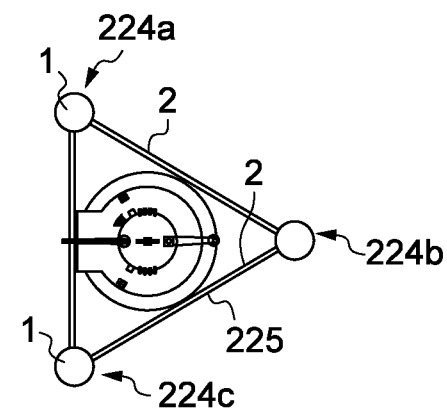

Fig. 3c

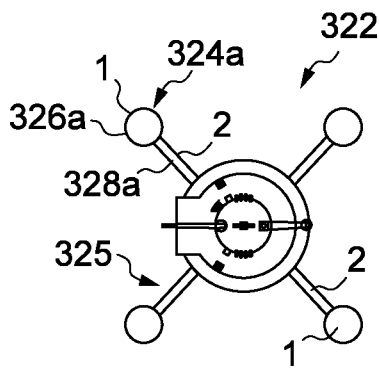

Fig. 4a

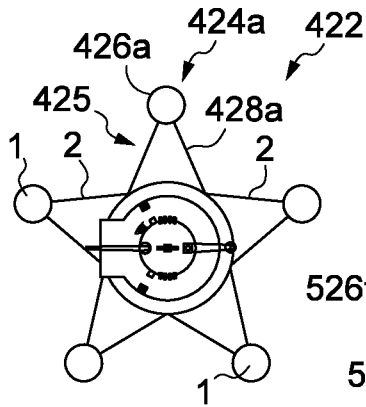

Fig. 4b

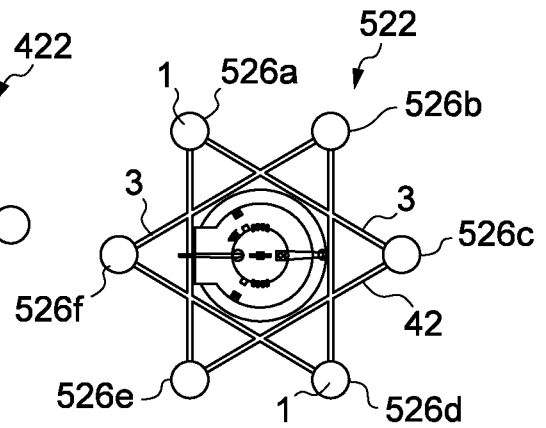

Fig. 4c

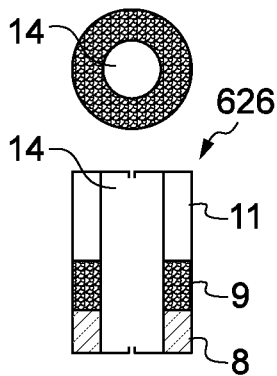

Fig. 5a

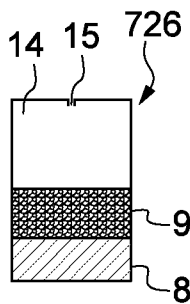

Fig. 5b

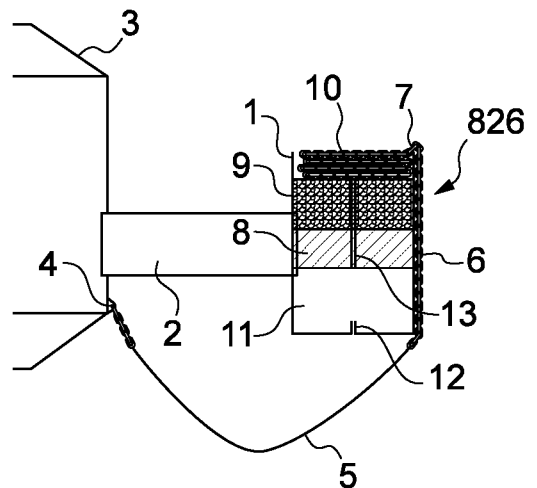

Fig. 5c

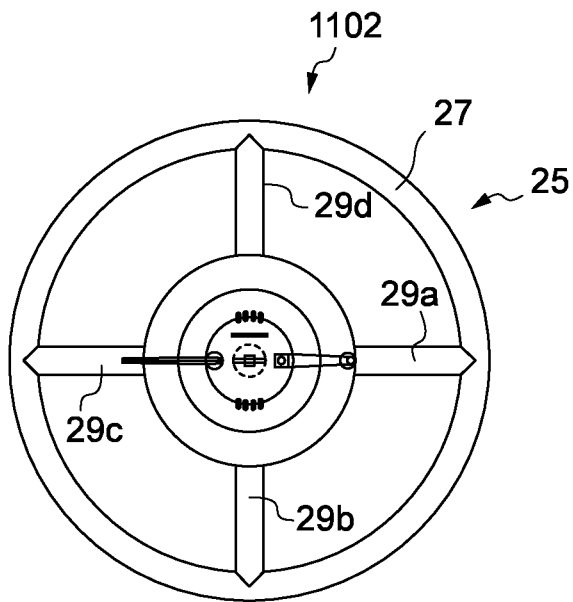

Fig. 4d

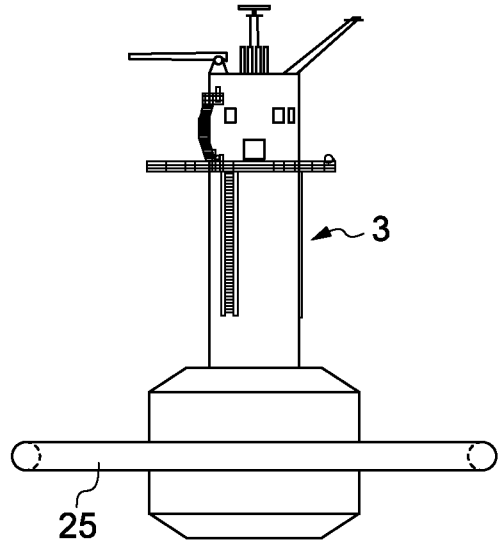

Fig. 4e

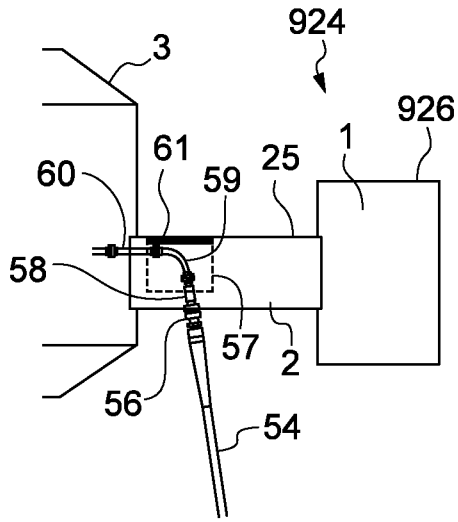

Fig. 6a

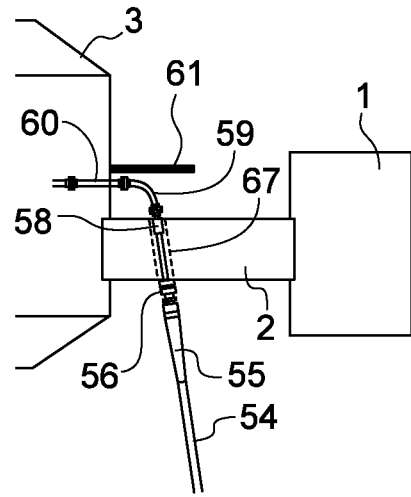

Fig. 6b

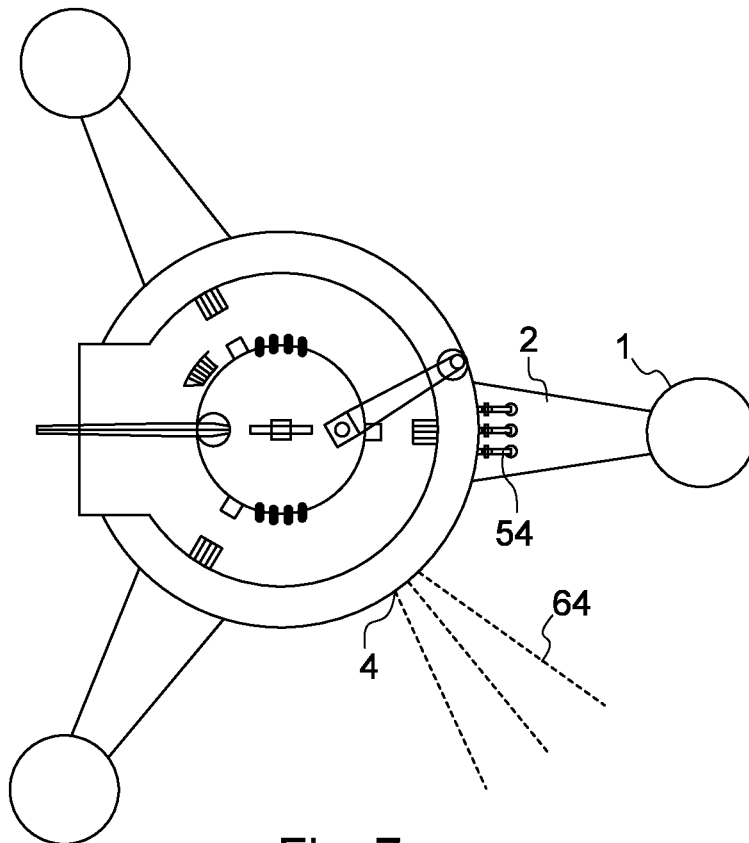

Fig. 7

INTERNATIONAL SEARCH REPORT

International application No PCT/GB2018/052465

A. CLASSIFICATION OF SUBJECT MATTER
INV. B63B39/06
ADD.

According to International Patent Classification (IPC) or to both national classification and IPC

B. FIELDS SEARCHED

Minimum documentation searched (classification system followed by classification symbols)
B63B

Documentation searched other than minimum documentation to the extent that such documents are included in the fields searched

Electronic data base consulted during the international search (name of data base and, where practicable, search terms used)
EPO-Internal, WPI Data

C. DOCUMENTS CONSIDERED TO BE RELEVANT

Category*	Citation of document, with indication, where appropriate, of the relevant passages	Relevant to claim No.
X	CN 205 418 007 U (OCEAN UNIV CHINA) 3 August 2016 (2016-08-03) figures 1-3	1-4,12, 13,15-17
X	-----	
X	JP 2012 091690 A (MITSUBISHI HEAVY IND LTD) 17 May 2012 (2012-05-17) figures 1-6	1-4,11, 12, 14-19,23
X	-----	
X	EP 2 708 742 A1 (ALSTOM WIND SLU [ES]) 19 March 2014 (2014-03-19) paragraphs [0029] - [0035]; figures 2,3,5-8	1,5-12, 14-20, 24,26,27

	-/--	

Further documents are listed in the continuation of Box C. See patent family annex.

* Special categories of cited documents :

<p>"A" document defining the general state of the art which is not considered to be of particular relevance</p> <p>"E" earlier application or patent but published on or after the international filing date</p> <p>"L" document which may throw doubts on priority claim(s) or which is cited to establish the publication date of another citation or other special reason (as specified)</p> <p>"O" document referring to an oral disclosure, use, exhibition or other means</p> <p>"P" document published prior to the international filing date but later than the priority date claimed</p>	<p>"T" later document published after the international filing date or priority date and not in conflict with the application but cited to understand the principle or theory underlying the invention</p> <p>"X" document of particular relevance; the claimed invention cannot be considered novel or cannot be considered to involve an inventive step when the document is taken alone</p> <p>"Y" document of particular relevance; the claimed invention cannot be considered to involve an inventive step when the document is combined with one or more other such documents, such combination being obvious to a person skilled in the art</p> <p>"&" document member of the same patent family</p>
---	---

Date of the actual completion of the international search 16 October 2018	Date of mailing of the international search report 25/10/2018
---	---

Name and mailing address of the ISA/ European Patent Office, P.B. 5818 Patentlaan 2 NL - 2280 HV Rijswijk Tel. (+31-70) 340-2040, Fax: (+31-70) 340-3016	Authorized officer Mauriès, Laurent
--	---

INTERNATIONAL SEARCH REPORT

International application No

PCT/GB2018/052465

C(Continuation). DOCUMENTS CONSIDERED TO BE RELEVANT		
Category*	Citation of document, with indication, where appropriate, of the relevant passages	Relevant to claim No.
X	CN 103 587 660 B (UNIV DALIAN TECH) 4 July 2017 (2017-07-04) figures 1-3 -----	1,4-13, 15-21, 23,24
X	US 3 429 127 A (DONKERS JACOBUS M) 25 February 1969 (1969-02-25) column 3, line 3 - line 43; figures 1,2 -----	1,5-11, 15-23

INTERNATIONAL SEARCH REPORT

Information on patent family members

International application No PCT/GB2018/052465

Patent document cited in search report	Publication date	Patent family member(s)	Publication date
CN 205418007	U	03-08-2016	NONE

JP 2012091690	A	17-05-2012	NONE

EP 2708742	A1	19-03-2014	EP 2708742 A1 19-03-2014
			US 2014079548 A1 20-03-2014

CN 103587660	B	04-07-2017	NONE

US 3429127	A	25-02-1969	DE 1634651 A1 17-09-1970
			GB 1135273 A 04-12-1968
			NL 6501996 A 18-08-1966
			US 3429127 A 25-02-1969
