

**DESCRIPTION**

**“SEMIAUTOMATIC ANTERIOR ANKLE FOOT ORTHOSIS”**

5

**FIELD OF THE INVENTION**

The present invention is enclosed in the area of orthosis. An orthosis or orthotics, as defined by ISO, is a support or external device applied to the body to modify the functional or structural aspects of the neuro musculoskeletal system to obtain some mechanical or orthopaedic advantage. In the present invention, is an anterior ankle foot orthosis.

**PRIOR ART**

15

Amyotrophic Lateral Sclerosis (ALS) is a progressive neurodegenerative and fatal condition, caused by the degeneration of the motor neurons, leading to the reduction of the voluntary movements. Due to the disease’s progression, subjects start presenting reduction of lower and upper limb strength and are advised during a period of time to use special technical aids to enhance their functional performance. In the early stages of lower limb deterioration of function, it's highly common to quickly lost the control (active force) to realize dorsiflexion of the foot. This means, for example, while walking, transferring, or performing any activity, if the foot is not externally supported it will turn into a drop foot.

25

Usually it is recommended the use of foot splints/lower limb orthotics that block the foot at a neutral position, avoiding the drop and the plantar flexion of the foot. The boxias are an effective solution and they allow driving, although they demand the user to produce an extra torque of strength induced by an oppositional resistance to the neutral position, which leads to a loss of agility and fatigue. And,

when the loss of strength is more noticeable, allied to a weak joint stabilization, the posterior splint is available, allowing effective stabilization of the joint, but does not allow plantarflexion, for instance while driving.

5                    Patent application US2005/0070834, discloses an active foot orthosis where the impedance of an orthotic joint is modulated throughout the walking cycle to treat ankle foot gait pathology, such as drop foot gait. The solution disclosed on this US patent application provides safe toe clearance in drop foot patients, but reduces muscle strength, by controlling its activity.

10                    The solution of the present invention provides an assistive device that promotes the control during gait movements and freedom during daily living activities, such as driving, for subjects that have ALS and the associated reduction of the voluntary movements as such drop foot. The orthosis of the present invention  
15 promotes the normal standards of human gait with amyotrophic lateral sclerosis (ALS). There are situations where the active plantar flexion of the foot is desired, and the actual solutions block or reduce it and does not adjust to different daily living activities. The object of the present invention is to provide a device capable of this adjustments without losing its safety. In view of this, we developed an active foot orthosis to avoid  
20 drop foot condition of the ALS disease. With the present solution the subjects with ALS keep their daily living activities during the progression of the injury, maintain foot support and promote a more active orthotic device that can be adapted to subjects' conditions.

                    The present solution creates varying degrees of plantar flexion limitation  
25 according to the user's muscular strength, which will stimulate an active muscle work and reduce the risk of muscle atrophy.

## **SUMMARY OF THE INVENTION**

It is therefore an object of the present invention an anterior ankle foot orthosis device comprising at least one pneumatic cylinder that is controlled by an electronic circuit.

The anterior ankle foot orthosis device of the present invention allows the release of plantar flexion muscles, helps to control dorsiflexion movement and improves the subjects ability for activities requiring plantar flexion, such as driving a car or rehabilitation techniques.

The purpose of this device is to promote the normal standards of human gait in subjects with amyotrophic lateral sclerosis (ALS), more specifically to avoid drop foot gait condition of the ALS disease.

The anterior ankle orthosis device of the present invention increases the capacity of proprioception and assists throughout the cycle of march because it allows the own user to control and achieve better movements.

It is also an object of the present invention process for manufacturing the anterior ankle foot orthosis that comprises the following steps:

- a) Cast the subject's lower limb;
- b) Cast modification;
- c) Mould the anterior ankle foot orthosis with a high-density thermoplastic;
- d) Place the pneumatic cylinders on the orthosis and adjust them according to subject's strength;
- e) Assemble the electromechanical actuated valve in the pneumatic chamber of the pneumatic cylinder; and
- f) Assemble the electronic circuit on the pneumatic cylinder and batteries.

## **DESCRIPTION OF FIGURES**

Figure 1 – representation of an embodiment of the anterior ankle foot orthosis, wherein A represents the superior portion of the orthosis which involves the anterior  
5 area of the leg; B represents the inferior portion of the orthosis which involves the instep, C represents the pneumatic cylinder and X is the link of the joint.

Figure 2 – illustrates an embodiment of the electronic circuit.

## 10 **DETAILED DESCRIPTION**

The more general and advantageous configurations of the present invention are described in the Summary of the invention. Such configurations are detailed below in accordance with other advantageous and/or preferred embodiments  
15 of implementation of the present invention.

In a preferred embodiment the semiautomatic anterior ankle foot orthosis of the present invention comprises at least one pneumatic cylinder that is controlled by an electronic circuit, and that works in two moments a) with an open  
20 circuit, wherein the flow control valve is open and the air travels in and out of the chambers freely with no additional pressure inside the cylinders; as such, the user has complete freedom of joint movement; or b) with a closed circuit, the generated pressure acts as a motion damper to the users movement. This effect is important so that the user can safely carry out the cycle, despite the progressive reduction of  
25 muscle strength.

In a preferred embodiment the anterior ankle foot orthosis device comprises at least one pneumatic cylinder that is centrally assembled, considering the leg and the instep, or at least two pneumatic cylinders that are laterally assembled, considering subjects' anthropometrics and regarding the centre of the malleoli 2 to 6

centimetres (distal and proximal) from the centre of the malleoli as being the articular centre of the ankle. In the case of the lateral assembling there are at least two pneumatic cylinders that are connected to the orthosis by a set of screws or rivets and rims assembled to the thermoplastic structure.

5

In another preferred embodiment at least one pneumatic cylinder comprises at least one pneumatic chamber or the at least two pneumatic cylinders comprises at least two pneumatic chambers. The pneumatic cylinder allows an easy control of plantar flexion and dorsiflexion through regulation of the volume inside the pneumatic chambers and the user of this orthosis can practise all daily activities without restrictions. Associated to ALS disease is the drop equine foot condition that the pneumatic circuit prevents, since the pressure inside in the at least two pneumatic chambers is lower than air pressure, and self regulates the resistance to move the foot. In another way, when necessary, for instance when there is reduced movement or when freedom of movement is required in a rehabilitation process, the pneumatic circuit can work at air pressure, resulting on a low resistance motion of the pneumatic circuit.

In another preferred embodiment the at least one pneumatic chamber comprises at least one electromechanically actuated valve and the at least two pneumatic chambers comprises at least two electromechanically actuated valve. This electromechanically actuated valves controls the amount of air that flows inside the at least two pneumatic chambers, providing free feet movement of the users orthosis of the present invention. In fact, a resistance effect is introduced by the addition of the electromechanically actuated valves into the at least two pneumatic chambers. The electromechanically actuated valves is electronically tighten to offer a controlled resistance to the air flow in and out of the pneumatic chambers. The pneumatic cylinders provide control over the freedom of movement of the feet by using the pressure inside the pneumatic chambers.

In a most preferred embodiment the electromechanically actuated valve of the pneumatic chambers is chosen from valves L16 or B25.

5 In another preferred embodiment the electromechanically actuated valve is controlled by an electronic circuit that opens or closes the amount of input of air into the pneumatic chambers, which is controlled through a mobile application via Bluetooth® Low Energy technology. Relieving the pressure on the foot allows a more proprioceptive contact area and improves the muscle movement, and at same time reduces the velocity of muscle atrophy that is linked to ALS disease. An increased  
10 proprioceptive contact area allows subjects to be more autonomous in their daily living activities.

The electronic circuit opens or regulates the electromechanically actuated valve state accordingly to the desired moment.

15 In another preferred embodiment the electromechanically actuated valve is preferably a stepper-controlled needle valve, which are fast transitioned between positions and only consume energy while switching positions, allowing for better power savings. This actuated valve opens or closes the pneumatic chambers depending the necessity of the patient. The amount of air that enters or leaves the  
20 pneumatic chambers is thus controlled through a mobile application via Bluetooth® Low Energy technology. This allows the user to control the status of the orthosis in any day-to-day situation and adjusts to their needs immediately. With this system we intend to manage the pressure and reduce/increase the resistance applied in the orthosis, according to muscular strength and level of disease progression and/or  
25 physical limitation.

In another embodiment the electronical circuit comprises an Arduino nano, a HC-05 Bluetooth module, and a relay. Figure 2 shows the circuit connections. The instructions concerning the amount of air that enters or leave of the pneumatic chambers is given trough a mobile application via Bluetooth® and using a specific app

that was built for this purpose. User can control the opening or closing the electromechanically actuated valve.

In another preferred embodiment the structure of the anterior ankle  
5 foot orthosis of the present invention is manufactured with a high density thermoplastic, to provide a good fit for the users' foot and allows to insert the orthosis inside the shoes.

In a most preferably embodiment the high-density thermoplastic is  
10 polyethylene or polypropylene.

In another preferred embodiment the structure of the anterior ankle  
foot orthoses is connected to the foot and leg with at least two bands of Velcro, one  
part is fixed in the anterior part of the thermoplastic in the area of the calf and in the  
15 metatarsal heads using rivets and the second part surrounds the limb in the calf and  
the metatarsal heads and is fixed to the first part.

In a preferred embodiment of the present invention the process for  
manufacturing the anterior ankle foot orthosis comprises the following steps:

20

- a) Cast the subjects lower limb using wet plaster bandages, from the distal part of the foot until the proximal area of the head of the fibula, rounding the limb. After the thermoplastic dries, a negative impression of the limb is obtained and the bonne areas are marked;
- 25 b) Cast modification with filing the negative impression with plaster and the plaster bandages are taken off when the moisture is dry;
- c) Mould the anterior ankle foot orthosis with a high-density thermoplastic, defining the limits of ankle foot orthosis and cutting it;

d) Assemble the pneumatic cylinders on the orthosis, to make sure that the plantar flexion and dorsiflexion are achieved without trouble or pain; and adjust them according to subject's strength; and

5 e) Assemble the electromechanical actuated valve in the pneumatic cylinder which is controlled by the electronic component.

In a preferred embodiment on casting of step a) each area of the limb is rounded by three layers of bandages, so the cast can be strong enough and each bandage is linked in the middle of the previous bandage.

10

In a preferred embodiment after step b) is made a 2 to 3 mm flat area of plaster, in length, from the head of the fibula until 2 cm to the centre of the malleoli in both lateral and medial sides. This procedure is repeated for the areas from the metatarsal heads until 2 cm of the head of the malleoli. After finishing  
15 this process, a plaster is inserted between the two areas, rounding the area of the tibia, tarsal and metatarsal bones, creating an area of 3-7 mm, in both lateral and medial sides. To finish the cast modification process a metal net and a wet plaster bandage are used, to ensure all structures are evenly distributed.

20

As will be clear to one skilled in the art, the present invention should not be limited to the embodiments described herein, and several changes are possible, which remains within the scope of the present invention.

25

Of course, the preferred embodiments shown above are combinable, in the different possible forms, being herein avoided the repetition of all such combinations.



**CLAIMS**

1. A semiautomatic anterior ankle foot orthosis, characterised in that it comprises at least one pneumatic cylinder controlled by an electronic circuit  
5 wherein the at least one pneumatic cylinder is centrally assembled from the upper portion of the orthosis corresponding to the leg to the instep of the orthosis, or at least two pneumatic cylinders controlled by an electronic circuit wherein the at least two pneumatic cylinders are laterally assembled from the centre of the malleoli as being the articular centre of the ankle.

10

2. The ankle foot orthosis according to previous claim wherein the at pneumatic cylinders comprises at least one pneumatic chamber.

3. The ankle foot orthosis according to any of the preceding claims  
15 wherein the at least one pneumatic chamber comprises at least one electromechanically actuated valve, preferably a stepper-controlled needle valve.

4. The ankle foot orthosis according to claim 3 wherein the stepper-controlled needle valve is chosen from L16 or B25.

20

5. The ankle foot orthosis according to any of the preceding claims wherein the at least one electromechanically actuated valve is controlled by an electronic circuit that opens or closes the amount of input of air into the pneumatic chambers.

25

6. The ankle foot orthosis according to any of the preceding claims wherein the electronical circuit is controlled through a mobile application via Bluetooth® Low technology.

7. The ankle foot orthosis according to claim 6 wherein electrical circuit comprises an Arduino nano, a HC-05 Bluetooth module, and a relay.

8. The ankle foot orthosis according to any of the preceding claims  
5 wherein the structure of the anterior ankle foot orthosis is a high density thermoplastic.

9. The ankle foot orthosis according to claim 8 wherein the high density thermoplastic is polyethylene or polypropylene.  
10

10. The ankle foot orthosis according to any of the preceding claims wherein the structure of the ankle foot orthosis is connected to the foot and leg with at least two bands of Velcro, one part is fixed in the anterior part of the high density thermoplastic in the area of the calf and in the metatarsal heads using rivets and the  
15 second part surrounds the limb in the calf and the metatarsal heads and is fixed to the first part.

11. A process for manufacturing the semiautomatic anterior ankle foot orthosis, characterised in that it comprises the following steps:  
20

a) Cast the subject's lower limb using wet plaster bandages, from the distal part of the foot until the proximal area of the head of the fibula, rounding the limb. After the thermoplastic dries, a negative impression of the limb is obtained and the bonne areas are marked;

25 b) Cast modification with filing the negative impression with plaster and the plaster bandages are taken off when the moisture is dry;

c) Mould the anterior ankle foot orthosis with a high-density thermoplastic, defining limits of ankle foot orthosis and cutting it;

d) Assemble the pneumatic cylinders on the orthosis and adjust them according to subject's strength;

e) Assemble the electromechanical actuated valve in the pneumatic chamber of the pneumatic cylinder;

5 f) Assemble the electrical circuit on the pneumatic cylinder and batteries.

12. A process for manufacturing the semiautomatic anterior ankle foot orthosis according claim 9 wherein the casting of step a) each area of the limb is rounded by three layers of bandages.

10 13. A process for manufacturing the semiautomatic anterior ankle foot orthosis according any claims 9-10 wherein after step b) is made a 2 to 3 mm flat area of plaster, in length, from the head of the fibula until 2 cm to the centre of the malleoli in both lateral and medial sides this procedure is repeated for the areas from the metatarsal heads until 2 cm of the head of the malleoli and after finishing this  
15 process, a plaster is inserted between the two areas, rounding the area of the tibia, tarsal and metatarsal bones, creating an area of 3-7 mm, in both lateral and medial sides.

14. A semiautomatic anterior ankle foot orthosis according any preceding claims wherein the orthosis is used to treat a patient with drop foot gait  
20 condition associated to amyotrophic lateral sclerosis (ALS).

**ABSTRACT**

**“SEMIAUTOMATIC ANTERIOR ANKLE FOOT ORTHOSIS”**

The present invention discloses a semiautomatic anterior ankle foot orthosis that comprises at least one pneumatic cylinder controlled by an electronic circuit wherein the at least one pneumatic cylinder is centrally assembled from the upper portion of the orthosis corresponding to the leg to the instep of the orthosis, or at least two pneumatic cylinders controlled by an electronic circuit wherein the at least two pneumatic cylinders are laterally assembled from the centre of the malleoli as being the articular centre of the ankle. The present invention also discloses a process for manufacturing the semiautomatic anterior ankle foot orthosis.

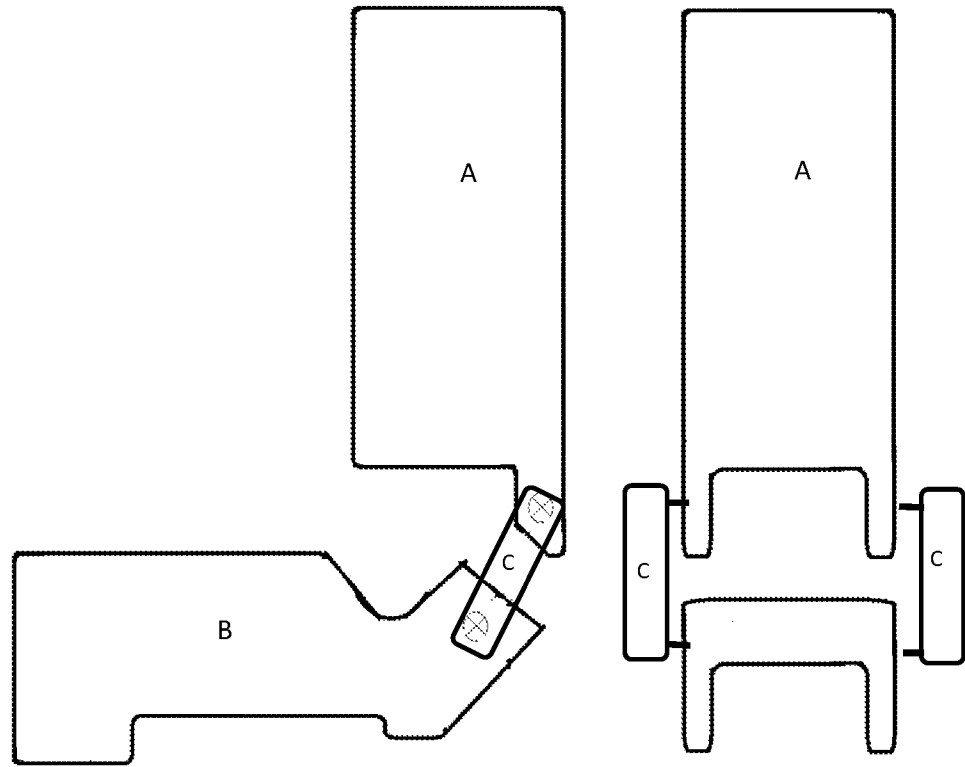

Figure 1

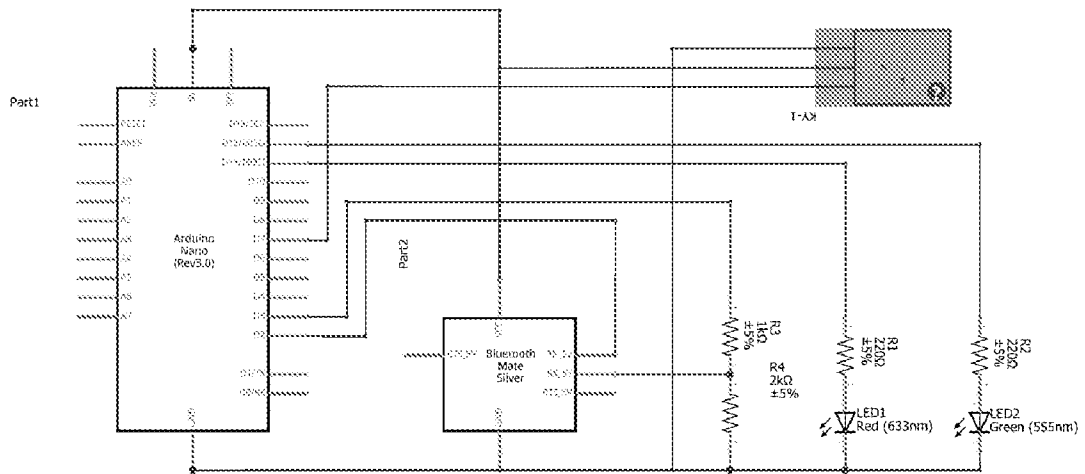

Figure 2