

DOCUMENT MADE AVAILABLE UNDER THE PATENT COOPERATION TREATY (PCT)

International application number:	PCT/MY2017/050014
International filing date:	04 April 2017 (04.04.2017)
Document type:	Certified copy of priority document
Document details:	Country/Office: MY
	Number: PI 2017700605
	Filing date: 22 February 2017 (22.02.2017)
Date of receipt at the International Bureau:	19 April 2017 (19.04.2017)

Remark: Priority document submitted or transmitted to the International Bureau in compliance with Rule 17.1(a),(b) or (b-bis)



PERBADANAN HARTA INTELEK MALAYSIA
INTELLECTUAL PROPERTY CORPORATION OF MALAYSIA
(Agensi di bawah KPDNKK)
Unit 1-7 & Mezzanine, Aras 12-19
Tower B, Menara UOA Bangsar
No. 5, Jalan Bangsar Utama 1
59000 KUALA LUMPUR
MALAYSIA



Tel : +603 - 2299 8400
Faks (Fax) : +603 - 2299 8989
Laman Web (Web) : www.myipo.gov.my

SASHIKUMAR RAO A/L RAMARAV
C/O NBS INTELLECTUAL SDN. BHD
I-3-3, BLOCK I, SETIAWALK,
PERSIARAN WAWASAN PUSAT BANDAR PUCHONG
47160 PUCHONG
SELANGOR DARUL EHSAN
MALAYSIA

PATENT APPLICATION NO. : PI 2017700605
APPLICANT NAME : DIAMOND STAR GLOBAL SDN. BHD

This is to certify that annexed hereto is a true copy from the records of the Patent Registration Office, Malaysia of the application as originally filed which is identified therein.

By authority of the
REGISTRAR OF PATENTS

YUHANES BIN MOHD ROZALI
CERTIFYING OFFICER
Date: 15 March 2017

(Agensi di bawah Kementerian Perdagangan Dalam Negeri, Koperasi dan Kepenggunaan)



Patents Form No.1 PATENTS ACT 1983 REQUEST FOR GRANT OF PATENT (Regulations 7(1)) To: The Registrar of Patents Patents Registration Office Kuala Lumpur, Malaysia	For Official Use APPLICATION NO: PI 2017700605 Filing Date: 22/02/2017 Fee received on: 22/02/2017 Amount: RM400
Please submit this Form in duplicate together with the prescribed fee	Applicant's file reference: NBS/DiamondStar2

THE APPLICANT(S) REQUEST(S) THE GRANT OF A PATENT IN RESPECT OF THE FOLLOWING PARTICULARS:

I. TITLE OF INVENTION: **METHOD OF USING A MAGNETIZED ANIONIC MINERAL WATER FOR IMPROVING ORGANOLEPTIC PROPERTIES OF ALCOHOLIC BEVERAGES**

II. APPLICANT(S) (the data concerning each applicant must appear in this box or , if the space insufficient, in the space below):

Name: **DIAMOND STAR GLOBAL SDN. BHD**
 I.C./Passport No:
 Address: **LOT 3734, TUPAI LIGHT INDUSTRIAL AREA, 34000 TAIPING PERAK MALAYSIA**
 Nationality: **MALAYSIA**

Address for service in Malaysia: **C/O NBS INTELLECTUAL SDN. BHD., I-3-3, BLOCK I, SETIAWALK, PERSIARAN WAWASAN PUSAT BANDAR PUCHONG, SELANGOR 47160 PUCHONG MALAYSIA**

* Permanent resident or principal place of business:

Telephone Number (if any) Fax Number (if any) Additional Information (if any)

Additional Information (if any)

III. INVENTOR:

Applicant is the inventor: Yes No

If the applicant is not the inventor

Name: **CHUAH CHONG KWIK**
 Address: **DIAMOND STAR GLOBAL SDN. BHD, LOT 3734, TUPAI LIGHT INDUSTRIAL AREA, 34000 TAIPING PERAK MALAYSIA**

Applicant is the inventor: Yes No

If the applicant is not the inventor

Name: **LOH SHIN SIONG**
 Address: **DIAMOND STAR GLOBAL SDN. BHD, LOT 3734, TUPAI LIGHT INDUSTRIAL AREA, 34000 TAIPING PERAK MALAYSIA**

A statement justifying the applicant's to the patent accompanies this Form

Yes No

Additional Information (if any)

IV. AGENT OR REPRESENTATIVE:

Applicant has appointed a patent agent in accompanying Form No. 17 Yes No

Agent Registration No:

Applicant has appointed to be their representative: **SASHIKUMAR RAO A/L RAMARAV**

V. DIVISIONAL APPLICATION:

This application is a divisional application

The benefit of the filing date priority date

of the initial application is claimed in as much as the subject-matter of the present application is contained in the initial application identified below :

Initial Application No:

Date of filing of initial application:

Additional Information (if any)

VI. DISCLOSURE TO BE REGARDED FOR PRIOR ART PURPOSES:

(a) Disclosure was due to acts of applicant or his predecessor in title

Date of disclosure:

(b) Disclose was due to abuse of rights of applicant or his predecessor in title

Date of disclosure:

A statement specifying in more detail the facts concerning the disclosure accompanies this Form.

Yes No

Additional Information (if any)

VII. PRIORITY CLAIM (if any)

The priority of an earlier application is claimed as follows :
Country (if the earlier application is a regional or international application, indicate the office with which it is filed) :

Filing Date:

Application No:

Symbol of the International Patent Classification:

If not yet allocated, please tick

The priority of more than one earlier application is claimed

Yes No

The certified copy of the earlier application(s) accompanies this Form

Yes No

If No, it will be furnished by Date:

Additional Information (if any)

VIII. CHECK LIST

A. This application contains the following:

1. Request	1	sheets
2. Description	10	sheets
3. Claim	2	sheets
4. Abstract	1	sheets
5. Drawings	2	sheets
Total	16	sheets

B. This Form, as filed, is accompanied by the items checked below :

- (a) Signed Form No. 17
- (b) Declaration that inventor does not wish to be named in the patent
- (c) Statement justifying applicant's right to the patent
- (d) Statement that certain disclosure be disregarded
- (e) Priority document (certified copy of earlier application)
- (f) Cash, cheque, money order, bank draft or postal order for the payment of application fee
- (g) Other documents (specify)

IX. SIGNATURE:

mail=sashi@nbs.com.my, cn=Sashi Rao, ou=Contact Number - 0165572744, ou=Identity Card / Passport No - #####, ou=Terms of use at www.msctrustgate.com/rpa (c)00, ou=Bahagian Teknologi Maklumat V2, o=Perbadanan Harta Intelek Malaysia, l="NBS INTELLECTUAL SDN. BHD., I-3-3, Block I, Setiawalk, Persiaran Wawasan, Pusat Bandar Puchong," st=47160 Selangor, c=MY, CertSerialNo=2894accb83a1b8abc67700daa5ffc85] **(~~Applicant~~/Agent)

22/02/2017

(Date)

If Agent, indicate Agent's Registration No.:

For Official Use

Date application received: 22/02/2017

Date of receipt of correction, later filed papers or drawings completing the application: -

* Delete whichever do not apply

** Type name under signature and delete whichever do not apply

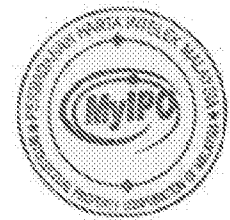

Attached Document

[D025-889779-20170221_Form17_MethodOfUsing.pdf](#)
[D037-889779-Final2_Tannis_Abstract_15Feb2017.pdf](#)
[D038-889779-Tannis_Draft_Drawing_15Feb2017.pdf](#)
[D062-889779-Final2_Tannis_Description_15Feb2017.pdf](#)
[D063-889779-Final2_Tannis_Claims_15Feb2017.pdf](#)
[D093-889779-DiamondStar_Form22_METHOD OF USING.pdf](#)
[D093-889779-DiamondStar_Form22_MethodOfUsing.pdf](#)
[DiamondStar_Form22_METHOD OF USING.pdf](#)

METHOD OF USING A MAGNETIZED ANIONIC MINERAL WATER FOR IMPROVING ORGANOLEPTIC PROPERTIES OF ALCOHOLIC BEVERAGES

FIELD OF INVENTION

5

This present invention relates to a system and method for improving the organoleptic properties of various alcoholic beverages by using a liquid having magnetic properties.

BACKGROUND OF THE INVENTION

10

In general, all wine and liquor contains a certain degree of tannins that add bitterness and astringency as well as complexity to the wine or liquor. Tannin, a naturally occurring polyphenols in plants, seeds, bark, wood, leaves and fruit skins such as grapes. Although, polyphenols have been recognized as anti-oxidants that have many health promoting properties in human, tannins in wine render the alcoholic beverages bitter, harsh, astringent, dry tasting that may reduce the acceptance to some consumer. It is well known that the older wine generally has softer texture, smoother and fruitier taste than the same wine at a younger age due to the degree of tannins polymerization that occur during wine aging. It is notable that the tannins will disperse throughout the years and in this manner all in all a more older wine will have a milder, smoother and fruitier taste than it did as a younger wine.

15

There are few patents describing alteration of tannins composition in alcoholic beverages by exposing the alcoholic beverages to magnetic forces had been filed previously. In fact, the use of magnets to change the tannins composition in wine using a magnetic wine drinking cup was developed that remove the piquant flavour of alcoholic beverages and therefore make the perception of astringency less (U.S. Pat. No. 655413). U.S. Pat. No. 5556654 describes another approach by passing the alcoholic beverages through a magnetic field created by tubular permanent magnets prior to bottling to enhance the flavour.

20

25

30

- However, the use of magnetized anion mineral water for improving the organoleptic properties of alcoholic beverages are not known, as various of these prior art devices require direct contact of alcoholic beverages to the magnetic devices that were either by pouring the alcoholic beverages to a magnetic container (U.S. Pat. No. 655413), dipping a magnetic blade into the alcoholic beverages (U.S. Patent application 2006/0172041 A1) or pouring the wine through tubular permanent magnets during bottling (U.S. Pat. No. 5556654). Hence, the direct contact of alcoholic beverages with the magnetic devices could introduce contaminants to the drink and might have hygienic concerns.
- 10 Therefore, the present invention has solved the problem of the prior art devices by omitting the method of having direct contact of alcoholic beverages with magnetic devices and provides a more convenient and hygienic manner to improve the organoleptic properties of alcoholic beverages.

SUMMARY OF THE PRESENT INVENTION

One aspect of the present invention relates to a method for improving an organoleptic properties of beverage substance, comprising steps of; pouring a magnetized liquid into a container; and soaking the beverage substance into the container, in such way that the magnetized liquid weaken the intra-molecular bonding and enhance the inter-molecular bonding of molecules in alcoholic beverages such as polyphenols, water and alcohol molecules, such that the organoleptic properties of the beverage substance improved without having direct contact to the substance using a magnetized liquid.

Preferably, the beverage substance is stored in a container or original packaging such as bottle, glass or cups before soaking into the first container.

Preferably, the container is a closed or open ended container.

A further aspect of the present invention relates to a method of producing the magnetized liquid using a plurality of filtration medium, comprising steps of: passing the liquid through ion-exchange medium for releasing negative ions of the liquid to form an ionized liquid; enhancing the micro-nutrient density of the ionized water using an alkalizing minerals; forming the liquid into a smaller water molecule cluster with higher vibrational energy at molecular level and increase oxygen content of the liquid by using FIR emitting ceramic; and forming a magnetic field for increasing zeta potential of calcite and changing physical and chemical properties of the liquid molecules by using a magnetized medium.

Preferably, the steps of improving the organoleptic properties of beverage substance by modification of tannins structures and content.

Further, the present invention relates to method for improving an organoleptic properties of beverage substance, comprising steps of using a magnetized ball to increase viscosity and water vaporization rate, and reducing water tension of the magnetized water.

Another aspect of the present invention relates to a system for improving an organoleptic properties of beverage substance comprising a magnetized liquid poured into a container, wherein the beverage substance soaked into the container, in such way that the magnetized liquid weaken intra-molecular bonding and enhance the inter-molecular bonding of the liquid molecules to form a magnetic field such that the organoleptic properties of the beverage substance improved without having direct contact to the substance using a magnetized liquid.

Preferably, the magnetized liquid produced using a plurality of filtration medium, in which the filtration medium comprising: ion-exchange medium for releasing negative ions of the liquid to form an ionized liquid, alkalizing minerals for enhancing the micro-nutrient density of the ionized liquid; Far Infrared Rays (FIR) ceramic balls emitting far infrared energy for assisting the liquid form into smaller water molecule cluster with higher vibrational energy at molecular level and increasing oxygen content of the liquid; and magnetized medium for increasing zeta potential of calcite and changing physical and chemical properties of the liquid molecules to form a magnetic field.

Preferably, the organoleptic properties of beverage substance is improved by modification of tannins structures and content.

Preferably, the magnetized medium further increase viscosity and water vaporization rate, and reduce water tension of the magnetized water.

The present invention consists of features and a combination of parts hereinafter fully described and illustrated in the accompanying drawings, it being understood that various changes in the details may be made without departing from the scope of the invention or sacrificing any of the advantages of the present invention.

BRIEF DESCRIPTION OF THE DRAWINGS

To further clarify various aspects of some embodiments of the present invention, a more particular description of the invention will be rendered by references to specific
5 embodiments thereof, which are illustrated in the appended drawings. It is appreciated that these drawings depict only typical embodiments of the invention and are therefore not to be considered limiting of its scope. The invention will be described and explained with additional specificity and detail through the accompanying drawings in which:

10 Figure 1 illustrates a block diagram for producing Magnetized Water for improving organoleptic properties of alcoholic beverages.

Figure 2 illustrates one embodiment of an apparatus for producing Magnetized Water for improving organoleptic properties of alcoholic beverages.

15

Figure 3 illustrates another embodiment of an apparatus for producing Magnetized Water for improving organoleptic properties of alcoholic beverages.

DETAILED DESCRIPTION OF THE INVENTION

The present invention relates to a method and system for improving the organoleptic properties of various alcoholic beverages such as wine and liquor in a container by using a liquid having magnetic properties. In particular, the container of the alcoholic beverages are in contact with the magnetized liquid or soaked into the magnetized liquid, so that the magnetic properties can be transferred to alcoholic beverages across the container to improve the organoleptic properties of alcoholic beverages. Preferably, the alcoholic beverage container are made of glass or ceramic or any similar material that can transfer the effect of the magnetic properties.

The magnetized liquid contains higher energy potential of water molecules compared to normal water. The energy potential of water molecules of magnetized liquid can be increased majorly by Far Infrared Radiation (FIR) irradiation and magnetizing process when passing through the apparatus.

FIR energy (photons with quantum energy levels of 12.4 meV –1.7 eV) are preferably emitted by the FIR ceramic, which is absorbed by water molecules and increases the vibrational level of bonds in molecules.

There are preferably six vibrational modes covering symmetric and anti-symmetric stretching, scissoring, rocking, wagging and twisting. The dielectric properties of water molecules and the large dipole moment that generates this form of effects, which are the dominant factor in its activity.

Generally, the water molecules able to rotate or move freely in an oscillating electric field with little or almost no energy loss at lower frequency. However, if the frequency of the electric field reaches about 108 Hz levels, the rotational mode becomes hindered due to “dielectric friction” effect, hence the absorbed energy starts dissipating by colliding or striking to the nearest neighbouring solution [A.R. Sheppard, M. L. Swicord, Q. Balzano. Health Phys., 2008; 95(4):365–96]. The dielectric relaxation of water at 310 K is around

25 GHz where the rotational response of the dipoles to the electromagnetic field is spread over to a broad frequency range. The effect of this phenomenon in water is amplified by later subjecting the FIR irradiated water to magnetic field in the apparatus.

5 Further, magnetic exposure was also recognized to increase the coagulation rate of polystyrene lattices in solution [K. Higashitani, K. Okuhara and S. Hatade, *J. Colloid Interface Sci.*, 152 (1992) 125.], formation of CaCO₃ crystals from CaCl₂ and Na₂CO₃ solutions [K. Higashitani, A. Kage, S. Katamura, K. Imai and S. Hatade, *J. Colloid Interface Sci.*, 156 (1993) 90.], and the zeta potential and diffusivity of polystyrene
10 lattices in electrolyte solutions [K. Higashitani, H. Iseri, K. Okuhara, A. Kage and S. Hatade, *J. Colloid Interface Sci.*, 172 (1995) 383.]. The effect of the magnetic field on the physical and chemical properties of water could be explained on the basis of quantum field theory [A.C. Cefalas, S.Kobe,G.Drazic, E. Sarantopoulou, Z. Kollia, J. Strazisar, A. Meden, *Appl. Surf. Sci.* 254 (2008) 6715–6724., E. Del Giudice, G. Preparata, G. Vitiello,
15 Water as a free electronic dipole laser, *Phys. Rev. Lett.* 61 (1988) 1085–1088., A. Meden, *J. Comput. Theor. Nanosci.* 7 (2010) 1800–1805.], that describes the amplification of magnetic fluctuations inside the liquid by exchanging energy of external magnetic field with the angular momentum of a single water molecular rotor. Magnetized water has an increased viscosity and enthalpies, reduced surface tension of water [A.
20 Szczes , E. Chibowski, L. Hołysz, P. Rafalski, *Chemical Engineering and Processing* 50 (2011) 124–127.] and an increased water vaporization rate [J. Nakagawa, N. Hirota, K. Kitazawa, M. Shoda, *J. Appl. Phys.* 86 (1999) 2923–2925.]. Clearly, magnetized water has altered characteristics, in term of energy potential of water molecules. Thus, magnetized water has been claimed to have beneficial effects to health and other
25 applications.

When magnetized water containing water molecules with higher energy potential is used to soak container containing alcohol beverage, where the container preferably in a glass or ceramic container, the energy from water molecules of magnetized water is
30 transferred through continuous collision with the neighbouring molecules in the water through glass/ceramic to the alcohol beverage such as liquor. The various molecules in

the liquor, including tannin, proteins and alcohols, will receive the energy that increases their vibration that cause a change in their molecular structure particularly the large and complex molecules of tannin in liquor. The specifically located charged groups of complex molecules associate with the water molecules, and the absorbed energy affect the dielectric behaviour of the whole molecular-assembly. This is the major factor that enhances the organoleptic properties of alcohol beverage.

Numerous scientific research was conducted formerly to examine the effects of a magnetic field on aqueous solutions and also biomaterials. It was found that magnetic exposure increased the coagulation rate of polystyrene lattices in solution, formation of CaCO_3 crystals from CaCl_2 and Na_2CO_3 solutions, and the zeta potential and diffusivity of polystyrene lattices in electrolyte solutions. The effect of the magnetic field on the physical and chemical properties of water could be explained on the basis of quantum field theory, which describes the amplification of magnetic fluctuations inside the liquid by exchanging energy of external magnetic field with the angular momentum of a single water molecular rotor. Magnetized water has an increased viscosity and enthalpies, reduced surface tension of water and an increased water vaporization rate. Clearly, magnetized water has altered characteristics, in term of energy potential of water molecules. Thus, magnetized water has been claimed to have beneficial effects to health and other applications.

This present invented apparatus involves increasing the concentration of anions and minerals in the water before magnetized by permanent magnetic field to produce magnetized anionic mineral water with stronger energy that can be transferred to alcoholic beverages across the container (glass or ceramic) to improve the organoleptic properties of alcoholic beverages. Based on the professional examination report by a first-class Chinese certified sommelier and the Chinese Bureau of Wine, the Chinese Maotai spirit that has been soaked for 10 minutes in Diamond Star magnetized anionic mineral water has a smoother texture with a more blended taste with reduced bitterness and astringency as compared to the non-treated Maotai spirit of the same type; while the unique aroma of Maotai spirit and the other chemical properties were not affected.

Activated Charcoal Granules

Granular activated carbon is commonly used for removing organic constituents and residual disinfectants in water supplies via adsorption and catalytic reduction. Organics
5 are removed by adsorption and residual disinfectants are removed by catalytic reduction.

Anion Balls

Negative ion ceramic ball is made from natural stones through the nanometer processing, which can be continuously produced negative ions. The amount of
10 generating negative ions ranges from 1200 to 40000 p/s.cm³.

Maifan Mineral Rocks

Also known as "bakuhanseki", Maifan mineral rock is a special mineral rock used in Chinese medicine to treat various skin diseases. It is composed of minerals including but
15 not limited to plagioclase feldspar, orthoclase feldspar, hornblende and biotite (silicate minerals). Maifan mineral rock contains plenty of micronutrient elements, such as calcium, iron, zinc, magnesium, copper, and selenium that are essential to health. It increases the micronutrient density in the water.

Far Infrared Energy Ceramic Balls

Far infrared ceramic ball can release weak electric current (0.06mA) in the process of treating water. It has an effective adsorption of lead, Chromium and other toxicity heavy metals. The far-infrared mineralization can release the far-infrared ray, which can have resonance with water molecules and enables the water to form smaller molecule groups
25 and increase the oxygen content of water.

Magnetized Energy Balls

It provides permanent magnetic field to water and weaken the intra-molecular bonding while enhances the inter-molecular bonding in the water molecules. This causes
30 formation of smaller aggregates of water molecules and therefore increases the viscosity and water vaporization rate but reduces the water tension of magnetized water.

Figure 1 illustrates a perspective view of the apparatus (100) to generate magnetized anionic mineral water showing 5 types of water-processing materials packed in three tubular filter housing with a raw water inlet (101) and a water outlet. The water inlet (101) for attachment to the feeding water source is first passed through the activated carbon medium (102) in the first filter housing to remove unwanted organic constituents and chemical contaminants in the feeding water. Then the water enters the second filter housing that contained anion balls or ion-exchange medium (103) that release negative ions in the water. Thereafter, the ionized water flows into the third filter housing that contained layers of plurality medium such as Maifan mineral rocks or alkalizing minerals (104), far infrared energy ceramic balls (105) or Ceramics are known to generate passively Far Infrared Rays (FIR), and magnetized balls (106) which increases the zeta potential of calcite and changes the physical and chemical properties of water molecules into magnetized water (107).

15

Figure 2 illustrates a method of soaking of the alcoholic beverages in the original de-capped bottle (202) in the magnetized water (201) generated by the apparatus. The alcoholic beverages in its own container or bottle could be soaked directly in the magnetized anionic mineral water for 10 minutes to significantly improve the organoleptic properties of the alcoholic beverages. Figure 3 illustrates a method of soaking of the alcoholic beverages in a glass (302) in the magnetized water (301) generated by the apparatus. The alcoholic beverages in its own glass could be soaked directly in the magnetized anionic mineral water for 10 minutes to significantly improve the organoleptic properties of the alcoholic beverages.

25

The present invention may be embodied in other specific forms without departing from its essential characteristics. The described embodiments are to be considered in all respects only as illustrative and not restrictive. The scope of the invention is, therefore indicated by the appended claims rather than by the foregoing description. All changes, which come within the meaning and range of equivalency of the claims, are to be embraced within their scope.

30

CLAIMS

1. A method for improving an organoleptic properties of beverage substance, comprising steps of;
5 pouring a magnetized liquid into a container; and
 soaking the beverage substance into the container, in such way that the magnetized liquid weaken intra-molecular bonding and enhance the inter-molecular bonding of the liquid molecules to form a magnetic field such that the organoleptic properties of the beverage substance improved without having direct contact to the substance
10 using a magnetized liquid.
2. The method according to claim 1, the beverage substance is stored in another container before soaking into the first container.
- 15 3. The method according to claim 1, the container is a closed or open ended container.
4. The method according to claim 1, further includes producing the magnetized liquid using a plurality of filtration medium, comprising steps of:
 passing the liquid through ion-exchange medium (103) for releasing negative ions of
20 the liquid to form an ionized liquid;
 enhancing the micro-nutrient density of the ionized water using an alkalizing minerals;
 forming the liquid into a smaller water molecule cluster with higher vibrational energy at molecular level and increase oxygen content of the liquid by using FIR emitting
25 ceramic (105); and
 forming a magnetic field for increasing zeta potential of calcite and changing physical and chemical properties of the liquid molecules by using a magnetized medium.
- 30 5. The method according to claim 1, the steps of improving the organoleptic properties of beverage substance by modification of tannins structures and content.

6. The method according to claim 1, further comprising steps of using a magnetized ball to increase viscosity and water vaporization rate, and reducing water tension of the magnetized water (107).
- 5 7. A system for improving an organoleptic properties of beverage substance comprising a magnetized liquid poured into a container,
wherein the beverage substance soaked into the container, in such way that the magnetized liquid weaken intra-molecular bonding and enhance the inter-molecular bonding of the liquid molecules to form a magnetic field such that the organoleptic
10 properties of the beverage substance improved without having direct contact to the substance using a magnetized liquid.
8. The system (100) according to claim 7, wherein the magnetized liquid produced using a plurality of filtration medium, in which the filtration medium comprising:
15 ion-exchange medium (103) for releasing negative ions of the liquid to form an ionized liquid,
alkalizing minerals for enhancing the micro-nutrient density of the ionized liquid;
Far Infrared Rays (FIR) ceramic balls emitting far infrared energy for assisting the liquid form into smaller water molecule cluster with higher vibrational energy at
20 molecular level and increasing oxygen content of the liquid; and
magnetized medium (106) for increasing zeta potential of calcite and changing physical and chemical properties of the liquid molecules to form a magnetic field.
9. The system (100) according to claim 7, wherein the organoleptic properties of
25 beverage substance is improved by modification of tannins structures and content.
10. The system (100) according to claim 7, wherein the magnetized medium (106) further increase viscosity and water vaporization rate, and reduce water tension of the magnetized water (107).

ABSTRACT**METHOD OF USING A MAGNETIZED ANIONIC MINERAL WATER FOR IMPROVING
5 ORGANOLEPTIC PROPERTIES OF ALCOHOLIC BEVERAGES**

The present invention relates a method for improving an organoleptic properties of beverage substance, comprising steps of; pouring a magnetized liquid into a container; and soaking the beverage substance into the container, in such way that the magnetized
10 liquid weaken intra-molecular bonding and enhance the inter-molecular bonding of the liquid molecules to form a magnetic field such that the organoleptic properties of the beverage substance improved without having direct contact to the substance using a magnetized liquid.

15 **Figure 1.**

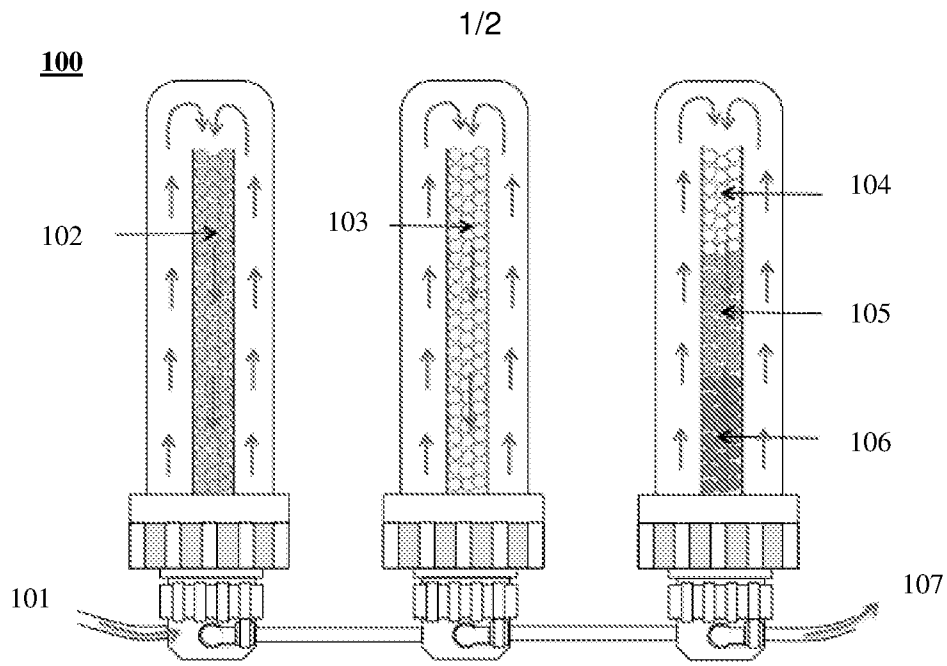

Figure 1.

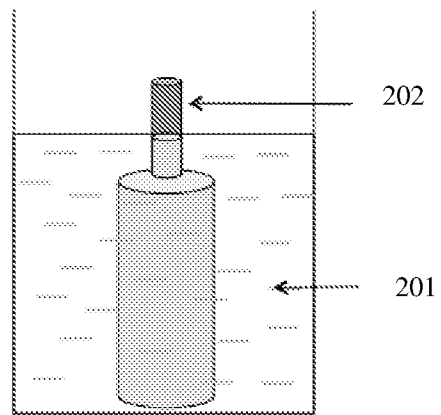

Figure 2.

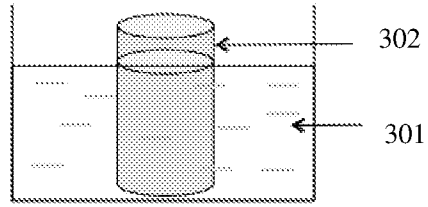

Figure 3.