

DOCUMENT MADE AVAILABLE UNDER THE PATENT COOPERATION TREATY (PCT)

International application number:	PCT/FI2016/050591
International filing date:	29 August 2016 (29.08.2016)
Document type:	Certified copy of priority document
Document details:	Country/Office: FI
	Number: 20155623
	Filing date: 31 August 2015 (31.08.2015)
Date of receipt at the International Bureau:	20 September 2016 (20.09.2016)

Remark: Priority document submitted or transmitted to the International Bureau in compliance with Rule 17.1(a),(b) or (b-bis)

Helsinki 08.09.2016

ETUOIKEUSTODISTUS
PRIORITY DOCUMENT

Hakija Applicant	David Health Solutions Oy HELSINKI
Patentihakemus nro Patent application no	20155623
Tekemispäivä Filing date	31.08.2015
Kansainvälinen luokka International class	A63B
Keksinnön nimitys Title of invention	

"ARRANGEMENT AND METHOD FOR ADJUSTING LOAD IN TRAINING EQUIPMENT"

Täten todistetaan, että oheiset asiakirjat ovat tarkkoja jäljennöksiä Patentti- ja rekisterihallitukselle alkuaan annetuista selityksestä, patenttivaatimuksista ja piirustuksista.

This is to certify that the annexed documents are true copies of the description, claims and drawings, originally filed with the Finnish Patent Office.

Maksu 70 EUR
Fee 70 EUR

Maksu perustuu työ- ja elinkeinoministeriön antamaan asetukseen Patentti- ja rekisterihallituksen maksullisista suoritteista.

The fee is based on the Decree with amendments of the Ministry of Employment and the Economy concerning the chargeable services of the Finnish Patent and Registration Office.

Postiosoite	P.O. Box 1160	Katuosoite	Arkadiankatu 6 A	Puhelin	+358 9 6939 500
Postal address	00101 Helsinki, FINLAND	Street address	00101 Helsinki, FINLAND	Telephone	
Pankki	IBAN: FI47 5000 0120 2535 79			Telefax	+358 9 6939 5328
Bank	BIC: OKOYFIHH				

ARRANGEMENT AND METHOD FOR ADJUSTING LOAD IN TRAINING EQUIPMENT

5 TECHNICAL FIELD

The present disclosure relates to an arrangement and a method for adjusting load in training equipment. Particularly, the invention relates to adjusting load in training equipment with
10 a monolithic weight, especially in training equipment situated outdoors.

BACKGROUND OF THE INVENTION

Load adjustment in training equipment is
15 typically achieved by weight plates or other removable, stackable or otherwise attachable loose, disconnectedly organized weight units. These kinds of solutions are habitually utilized in gyms and other indoor training facilities. In outdoor equipment,
20 there are typically no specific arrangements or methods for load adjustment. Instead, the load is derivable from the user of the equipment, either directly from the weight of the user, the weight of the moving parts of the equipment, or by for example,
25 adjusting the length of a torque arm by gripping it from different positions along the arm. This places serious limitations to the load adjustment of the training equipment, and may inhibit users for utilizing pieces of equipment when the fixed load is
30 not suitable for them.

On the other hand, weight plates and other such loose or removable weights are not suited for use in outdoor training equipment. Apart from storing, changing and maintenance issues, safety

issues restrict their use in outdoor training equipment. Also indoors, these kinds of weights for loading training equipment may cause accidents to the users. Furthermore, changing loose weights or weight
5 plates is time-consuming and can be even difficult for users with impaired abilities or simply less strength.

European standard EN 16630 concerning permanently installed, freely accessible outdoor
10 fitness equipment specifies general safety requirements for the manufacture, installation, inspection and maintenance of the equipment. Loose weights such that are commonly used in indoor training equipment, such as weight training equipment
15 in gyms, are not allowed in equipment intended for outdoor use according to EN 16630. Therefore, training equipment installed outdoors must have either monolithic, undividable weights for creating the load, employ other load adjustment arrangements,
20 or function without any adjustable load or weight arrangements. The latter naturally limits the utilization of such equipment.

SUMMARY OF THE INVENTION

25 An objective of the present invention is to provide an improved arrangement for adjusting load in training equipment, and a method for the same. The arrangement and the method is in particular, but not only, intended for training equipment fitted with a
30 monolithic or undividable weight, for example for outdoor weight training equipment with at least one movable arm. However, the arrangement and the method

are equally suitable for indoor use, and for training equipment of numerous different configurations.

The arrangement for adjusting load in training equipment comprising at least one moving arm
5 pivotably connected to a frame presented here is characterized by comprising at least one load unit, an elongated guideway along which the load unit is arranged to move, a locking device with which the load unit is secured into a position corresponding
10 the desired load of the training equipment, and a connector with which the guideway is pivotally connected to the training equipment via a fulcrum; and further characterized in that the guideway is connected both to the moving arm and to the frame of
15 the training equipment via the fulcrum.

In one embodiment of the invention, the guideway extends to both sides of the fulcrum, and the load unit is movable lengthwise on the guideway to a position on either side of the fulcrum.

20 In one embodiment of the invention, the load unit comprises a monolithic weight, at least one actuator with which the load unit is moved along the guideway, and a cover.

In one embodiment of the invention, the
25 locking device is arranged directly onto the load unit.

In one embodiment of the invention, the locking device comprises a gripping part with which the load unit is manually moved along the guideway,
30 an arm arranged to extend inside the load unit through the cover, an attaching element with which the arm is attached pivotably to the cover, and an

end part attachable into a counterpart (35a-c) arranged on the guideway.

In another embodiment, the end part and the counterpart form a form-lock when the load unit is secured into a position.

In yet another embodiment, the counterparts are a series of pre-determined locking positions corresponding to the desired load of the training equipment.

In another embodiment, the locking device is spring-loaded so that the end part is automatically secured into one counterpart in case the locking device is unintentionally set into a position between two adjacent counterparts.

In another aspect of the invention, there is disclosed a method for adjusting load in training equipment characterized by comprising at least one moving arm pivotably connected to a frame, at least one load unit, an elongated guideway along which the load unit is arranged to move, a locking device with which the load unit is secured into a position corresponding the desired load of the training equipment, and a connector with which the guideway is connected pivotally to the training equipment via a fulcrum; further characterized in the load unit is moved on the guideway extending to both sides of the common fulcrum, through which guideway and the moving arm are connected to the frame, to a position on either side of the fulcrum.

In one embodiment of the invention, the load unit is secured to a pre-determined locking position arranged onto the guideway to adjust the load in

stepwise manner within the pre-determined locking positions.

The invention according to the present disclosure offers specific advantages over prior art.

5 The disclosed arrangement for adjusting load in training equipment has a simple structure which makes it straightforward to manufacture, install and maintain once in use. The arrangement and method are easy to utilize. Safety requirements are fulfilled.

10 The disclosed arrangement enables adjusting the load of training equipment so that a relatively small change in length of a torque arm causes a significant change in load. This enables efficient and user-specific weight training. Also the dimensions of the training equipment can be kept
15 relatively small, and the equipment can be installed in places where only limited space is available.

BRIEF DESCRIPTION OF DRAWINGS

20 The accompanying drawings, which are included to provide a further understanding of the invention, and which constitute a part of this specification, illustrate embodiments of the invention. Together with the description the drawings
25 are meant to help to explain the principles of the invention. The invention is not limited to the specific embodiments illustrated in the drawings.

In the drawings:

30 **Fig. 1** presents a schematic side view of an arrangement for adjusting load in training equipment in one embodiment according to the present disclosure.

Fig. 2 presents a schematic, partially sectional overview of an embodiment of the arrangement according to the present disclosure, where the arrangement is viewed from behind the training equipment.

Fig. 3 presents a schematic, partially sectional overview of the load unit in one embodiment of the invention. In the figure, the load unit is viewed from the side of the training equipment.

The following reference symbols have been used to annotate different parts of the invention throughout the figures:

	1	training equipment unit
	10	moving arm
15	11	frame
	12	seat
	120	foot of the seat
	13	lower support frame
	14	handles
20	15	support arm
	2, 2b	load unit
	21	weight
	22	actuator
	23	cover
25	3, 3b	guideway
	35a-e	counterparts/locking positions
	4	connector
	5	locking device
	51	gripping part
30	52	arm
	53	attaching element
	54	end part
	6	fulcrum
	61	first side of the fulcrum
35	62	second side of the fulcrum

DETAILED DESCRIPTION OF THE EMBODIMENTS

Fig. 1 presents a piece of training equipment 1, more specifically a front press type strength training unit comprising a seat 12, its foot 120, a frame 11 which in this embodiment is a

vertical frame, a lower support frame 13, a moving arm 10 (in Fig. 1 flush behind a guideway 3 and therefore not directly visible), handles 14 arranged onto the moving arm 10 and the guideway 3, a support arm 15 for the moving arm and a load unit 2. The specific frame structure of the different training equipment units naturally depends on the type of exercise for which it is intended.

Typically, the frame structure 10, 11, 12, 13, 14, 15 of the training equipment is constructed of tubular steel tubes or pipes, bars, beams or similar elongated hollow pieces with either round, square, rectangular or other cross-sections. The pieces may also be solid. Also aluminum, wood or any wood-based material, or engineered composite materials such as plastic composites or any such durable materials are conceivable for the aforementioned structures.

In the embodiment of Fig. 1, the support arm 15 is arranged to receive the moving arm 10 and the guideway 3 at the start-off of the weight training movement so that the moving arm 10, the guideway 3 or the handles 14 do not hit or hurt the user should their grip from the handles slip. The movement of the training equipment unit 1 or its trajectory is therefore restricted by the support arm 15 on one end, and on the other end, by the user, or by a mechanical or structural restrictor or stop.

In the embodiment presented in Fig. 1, the training equipment unit 1 comprises a vertical frame 11 to which the guideway 3 and the moving arm 10 are pivotably connected via a common fulcrum 6 by any suitable connector. The connector can for example be

a bar or a rod, extending from the guideway 3 through the frame 11 to the moving arm 10, bearing-mounted on the moving arm 10, the guideway 3 and the frame 11, such as the one depicted in Fig. 2. Other possible
5 connectors enabling a pivotable or hinged connection through a common fulcrum or hub are conceivable.

The guideway 3 is an elongated structures made from the same type of material as the frame parts. The guideway 3 may for example be a hollow
10 metal rod made from steel or other metal, such as aluminum. It can also be made from wood or plastic or any other suitable durable material. The guideway 3 is connected both to the frame 11 and to the moving arm 10 via the common fulcrum 6 as described
15 previously. The guideway 3 extends to both sides 61, 62 of the fulcrum 6.

The load unit 2 is presented more closely in Fig. 2 and Fig. 3. The load unit 2 comprises an integral monolithic, i.e. undividable weight 21, at
20 least one actuator with which the load unit is moved along the guideway 3, and a cover 23.

The weight 21 can be any suitable monolithic piece of material, for example any metal, concrete, lead or stone. The weight 21 is integrally and
25 fixedly arranged into the load unit 2, 2b.

The actuator 22 or actuators in the embodiment presented in Fig. 2 and Fig. 3 are rolls, more specifically three rolls bearing-mounted on the cover 23 of the load unit with any suitable devices
30 and accustomed manner. The rolls 22 enable the movement of the load unit 2 along the guideway 3. The actuators may also be any other suitable means for

moving the load unit 2, such as wheels, a cable, a chain or a belt.

The cover 23 surrounds the weight 21, the parts of a locking device 5 located within the cover 5 23 and the actuators 22 in such a manner that they are protected from the weather and for example from vandalism. Furthermore, the cover 23 prevents the user from accidentally inserting fingers or other parts between the actuators 22 and the guideway 3 or 10 between the locking device 5 and counterparts 35a-e on the guideway 3.

The load unit 2 is moved along the guideway 3 by a locking device 5 arranged onto the load unit 2. The locking device 5 comprises a gripping part 51 15 or a handle with which the user engages and moves the load unit to a position 35a-3 along the guideway 3, the position 35a-e corresponding a desired load for the training equipment unit 1.

The locking device 5 further comprises an 20 arm 52 that extends inside of the load unit 2, i.e. into the part of the load unit 2 covered by the cover 23. The locking device 5 is attached pivotably to the cover 23 with an attaching element 53, for example by a pin, screw or bolt that extends through holes 25 arranged into the arm 52 and the cover 23 and that is secured to place either permanently or detachably.

The pivot connection enables two-directional 30 movement of the locking device 5: a first direction engages or fastens the locking device with the guideway 3, and the second, opposite direction removes or releases the locking device 5 from connection with the guideway 3.

The locking device 5 further comprises an end part 54 at the end of the arm 52 located inside the load unit 2. The end part 54 is a connecting part which is connectable with a counterpart 35a-e arranged onto the guideway 3 in such a way that the locking device 5 is attached into and removed from a counterpart 35a-e when the locking device 5 is pivoted by turning the gripping part 51.

The counterparts 35a-e can be holes, notches, indentations or similar machined or otherwise arranged into the guideway 3. The counterparts 35a-e are a series of pre-determined locking positions 35a-e that each correspond to a desired pre-determined load of the training equipment.

Optionally, the guideway may include markings indicating the load and/or weight each of the counterparts/locking positions 35a-e represent, so that the user can get an indication of the load they are employing in the weight training.

The dimensions of the counterparts 35a-e correspond to the dimensions of the end part 54 so that secure fastening of the load unit 2 into the guideway 3 is achieved through the connection of the end part 54 and the counterparts 35a-e.

The end part 54 and the counterpart 35a-e form a form-lock when the load unit 2 is secured into a desired position by turning the gripping part 51 to the first direction. The form-lock is deactivated or unlocked when the locking device 5 is pivoted to the second, opposite direction.

The locking device 5 is spring-loaded to enable automatic securing of the end part 54 to any

one counterpart 35a-e if the user accidentally or unintentionally tries to set or secure the load unit 2 into a position between two adjacent counterparts 35a-3. The spring-loading is achieved in any conventional manner, for example in connection with the attaching element 53.

In another embodiment of the arrangement for adjusting load in training equipment, also presented in Fig. 1, the training equipment unit 1 may comprise two load units 2, 2a. In that case, the second load unit 2b is arranged onto the moving arm 10, which acts as a second guideway 3b for the load unit 2b (the guideway 3b is not visible in Fig 1 since it is flush behind the guideway 3).

The moving arm 10 or the second guideway 3b is connected to the frame 11 and to the first guideway 3 via a common fulcrum 6. The second guideway 3b is arranged to extend to both sides 61, 62 of the fulcrum 6. The two load units 2, 2b are separately and independently movable along their respective guideways 3, 3b.

The second load unit 2b, its structure and operational details, is identical to the load unit 2 described above. Similarly, the second guideway 3b corresponds the guideway 3. For example, the second guideway 3b also comprises counterparts 35a-e which act as a series of pre-determined locking positions 35a-e that each correspond to a desired pre-determined load of the training equipment.

Optionally, the guideway 3b may also include markings indicating the load and/or weight each of the counterparts/locking positions 35a-e represent,

so that the user can get an indication of the total load they are employing in the weight training.

The method for adjusting load in training equipment disclosed herein is employed as follows:

5 The training equipment comprises a frame (11) and a moving arm (10). Together with the guideway 3 the moving arm 10 forms a torque arm or a training arm for the piece of training equipment, and the user can operate this training arm by engaging
10 the handles 14 arranged on the free ends of the moving arm 10 and the guideway 3. The moving arm 11 and the guideway 3 are pivotably connected to the frame 11 via a common fulcrum 6 by a connector 4.

15 The guideway 3 extends on both sides 61, 62 of the fulcrum 6, and the load unit 2 is arranged on the guideway 3 in such a way that it is freely movable along the guideway 2 on both sides 61, 62 of the fulcrum 6.

20 The load unit 2 comprises a locking device 5 with which the load unit 2 is moved and secured into a position 35a-e corresponding the desired load of the training equipment 1.

25 The selected load of the training equipment is therefore based on the position 35a-e of the load unit 2 and its weight 21 along the guideway 3: the closer to the handles 14 of the training equipment 1 the load unit 2 is positioned, the higher the load becomes, as the torque arm made up by the moving arm 10 and the guideway 3 shortens. Respectively, the
30 farther from the handles 14 the load unit 2 is positioned, the lower the load becomes, as the torque arm becomes longer.

In an alternative embodiment, adjusting the load may also be achieved continuously, i.e. without any pre-determined locking positions 35a-e arranged into the guideway 3. Then, a form-lock is formed
5 directly between the end part 54 of the locking device 5 and the guideway 3, which enables a wider range of possible training loads.

In another alternative embodiment where two load units 2, 2b are utilized, the two load units 2,
10 2b are separately and independently movable, load unit 2 on guideway 3 and load unit 2b on guideway 3b (i.e. moving arm 10). Both load units 2, 2b are movable on both sides of the fulcrum 6.

The load units 2, 2b can be moved to and
15 secured into positions on both sides 61, 62 of the common fulcrum 6. More specifically, load unit 2 may be arranged on the first side 61 and the second load unit 2b may be arranged to the second side 62, as is the case in Fig. 1, or vice versa. Alternatively,
20 both load units 2, 2b may be positioned on the first side 61 or on the second side 62.

The positioning of the two load units 2, 2b will naturally depend on the load the user of the training equipment unit 1 desires to employ in their
25 training. Two load units 2, 2b increase the range of possible training loads of the training arrangement unit 1 without affecting the dimensions or space requirements of the training equipment unit 1.

The above-described arrangement and the
30 above-described method are to be understood as only possible embodiments of the arrangement and the method for adjusting load in training equipment. It is to be understood that the arrangement may comprise

other parts or alternative assemblies, and that the method may comprise other steps or alternative ways of carrying out the method.

5 The arrangement for adjusting load can be arranged on any kind of weight training equipment, where a torque arm is employed to move a weight or a load in order to train one's body or parts of the body.

10 Instead of a single frame 11, the equipment unit 1 can also be arranged as a part of a training stand comprising several pieces of equipment utilizing at least partly the same support or frame structures. Furthermore, instead of a vertical frame 11, the moving arm 10 and the guideway 3 can be
15 arranged onto a wall, column, pillar or any other vertical surface in a pivotable manner.

Instead of a single moving arm 10 the training equipment may also comprise two or more moving arms, connected to each other to form an
20 extended torque arm with pivot points. The torque arm formed by the moving arm 10 and the guideway 3 may enable several different trajectories or paths of movement.

25 A basic structure, such as the one in the above-described embodiment, may also include different additional structures, pieces or arms for implementing or executing different paths of movement. A training equipment unit may for example include a secondary moving arm and transmitting
30 elements which transmit the load from the primary moving arm or torque arm to the secondary moving arm, in which case the primary moving arm acts as the load unit.

The structure, setup and layout of the moving arm, arms or other functional parts of the training equipment unit will naturally depend wholly on the type of strength training to which it is intended. The basic principle of the present invention remains, however, the same: the load unit 2, 2b is movable on both sides 61, 62 of the fulcrum 6 through which the different parts 3, 3b, 10, 11 are interconnected by the connector 4.

Instead of fastening the load unit 2, 2b into pre-determined positions 35a-e arranged onto the guideway 3, 3b as holes, indentations, grooves or other such definite locking positions 35a-e, to adjust the load in a stepwise manner, the load unit 2, 2b can also be arranged to be secured to any desired position along the guideway 3, 3b freely selectable for adjusting the load continuously.

The arrangement and method for adjusting load in training equipment according to the invention are especially suitable for outdoor installations, where conditions (weather, wear, infrequent maintenance, vandalism etc.) place certain requirements for the load unit. Since the load unit is fully covered and therefore shielded from outside elements, and since it comprises an integrated monolithic weight with no moving or detachable parts, it is durable and requires very little maintenance. Furthermore, the equipment comprising the arrangement according to the invention is both easy and safe to the user to manipulate, and fulfills the requirements of the European standard EN 16630.

With the disclosed invention, a relatively small change in length of the torque arm causes a

significant change in load. Therefore only a short or very limited movement area is needed to achieve a maximum load for an individual user. Hence, that the dimensions of the training equipment, especially perpendicular to the movement of the particular training method can be kept small, and the equipment can be installed in places where only limited space is available.

The specific positioning of the fulcrum in relation to the user's range of movement in each exercise is used to provide a biomechanically optimal and safe resistance curve during the execution of each movement. This resistance curve is individual for each movement and is based on the following facts:

1. the force/length relationship of the skeletal muscles
2. change in the mechanical leverage (referring to the human musculoskeletal system) during any given movement
3. utilization of the potential energy during any given movement (stretch/shortening cycle)
4. effect of fatigue on the force production during a set of repetitions.

The above embodiments are to be understood as illustrative examples of the invention. Further embodiments of the inventions can be conceived. It is to be understood that any feature described herein in relation to any one embodiment may be used alone, or in combination with other features described, and may also be used in combination with one or more features of any other of the embodiments, or any combination of any other of the embodiments. Furthermore,

equivalents and modifications not described above may also be employed without departing from the scope of the invention, which is defined in the accompanying claims.

CLAIMS

1. An arrangement for adjusting load in training equipment (1) comprising at least one moving arm (10) pivotably connected to a frame (11), the arrangement comprising at least one load unit (2), an elongated guideway (3) along which the load unit (2) is arranged to move, a locking device (5) with which the load unit (2) is secured into a position corresponding the desired load of the training equipment (1), and a connector (4) with which the guideway (3) is pivotally connected to the training equipment (1) via a fulcrum (6), **characterized** in that the guideway (3) is connected both to the moving arm (10) and to a frame (11) of the training equipment (1) via the fulcrum (6).

2. The arrangement according to claim 1, **characterized** in that the guideway (3) extends to both sides (61, 62) of the fulcrum (6), and that the load unit (2) is movable along the guideway (3) to a position on either side (61, 62) of the fulcrum (6).

3. The arrangement according to claims 1 or 2, **characterized** in that the load unit (2) comprises a monolithic weight (21), at least one actuator (22) with which the load unit is moved along the guideway (3), and a cover (23).

4. The arrangement according to any of the claims 1 - 3, **characterized** in that the locking device (5) is arranged directly onto the load unit (2).

5. An arrangement according to any of the claims 1 - 4, **characterized** in that the locking device (5) comprises a gripping part (51) for

manually moving the load unit along the guideway (3),
an arm (52) arranged to extend inside the load unit
(2) through the cover (23), an attaching element (53)
with which the arm (52) is attached pivotably to the
5 cover (23), and an end part (54) attachable into a
counterpart (35a-c) arranged on the guideway (3).

6. An arrangement according to claim 5,
characterized in that the end part (54) and the
counterpart (35a-e) form a form-lock when the load
10 unit (2) is secured into a position.

7. An arrangement according to claim 5 or 6,
characterized in that the counterparts (35a-e) are a
series of pre-determined locking positions (35a-e)
corresponding to the desired load of the training
15 equipment unit.

8. An arrangement according any of the
claims 5 - 7, **characterized** in that the locking
device (5) is spring-loaded sot that the end part
(54) is automatically secured into one counterpart
20 (35a-e) in case the locking device (5) is
unintentionally set into a position between two
adjacent counterparts (35a-e).

9. A method for adjusting load in training
equipment (1) comprising at least one moving arm (10)
25 pivotably connected to a frame (11), at least one
load unit (2), an elongated guideway (3) along which
the load unit (2) is arranged to move, a locking
device (5) with which the load unit (2) is secured
into a position corresponding the desired load of the
30 training equipment (1), and a connector (4) with
which the guideway (3) is connected pivotally to the
training equipment (1) via a fulcrum (6),
characterized in the load unit (2) is moved on the

guideway (3) extending to both sides (61, 62) of the common fulcrum (6) through which guideway (3) and the moving arm (10) is connected to the frame (11), to a position on either side (61, 62) of the fulcrum (6).

5 10. The method according to claim 8, **characterized** in that the load unit (2) is secured to a pre-determined locking position (35 a-e) arranged onto the guideway (3) to adjust the load in stepwise manner within the pre-determined locking positions
10 (35a-e).

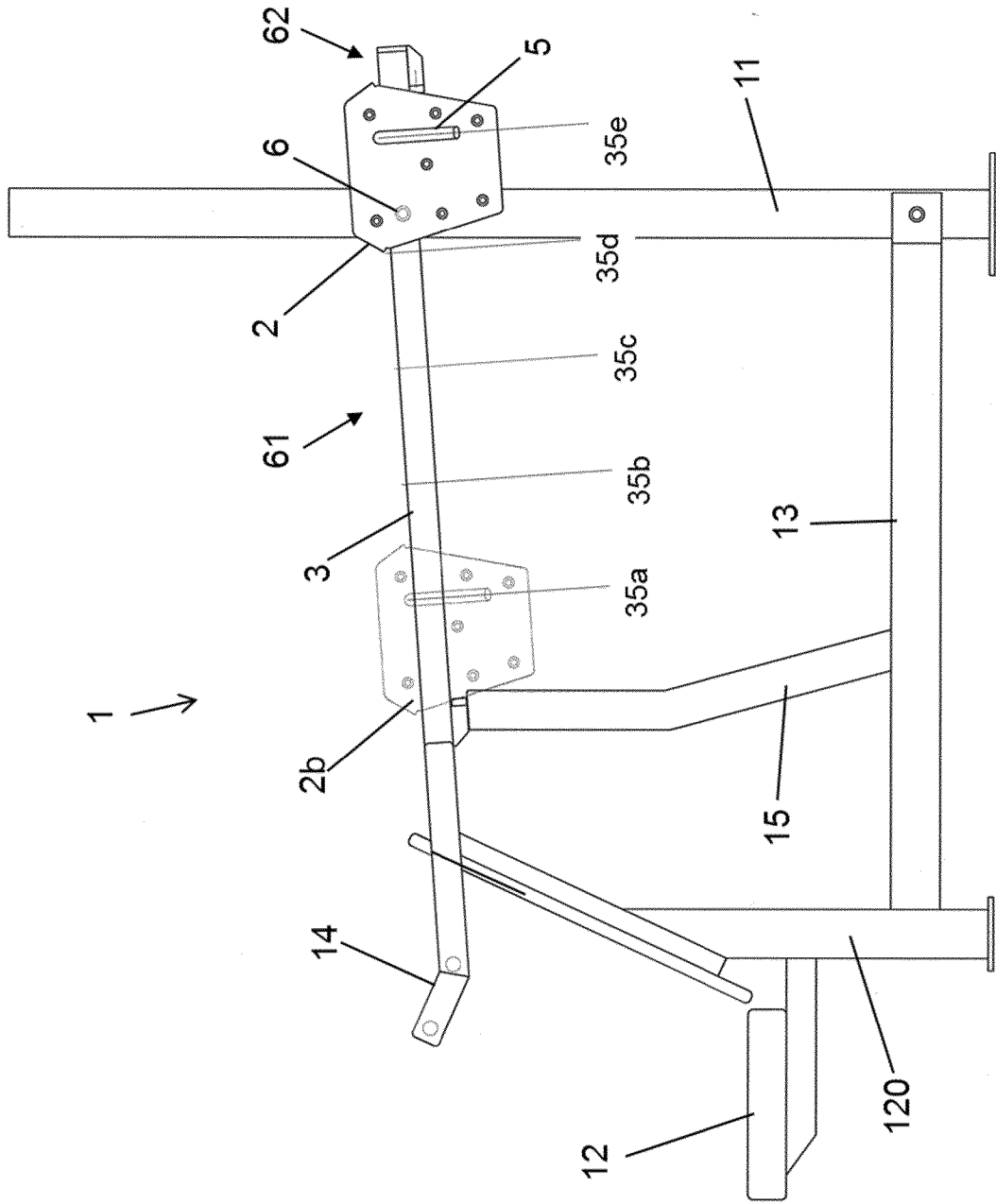

Fig.1

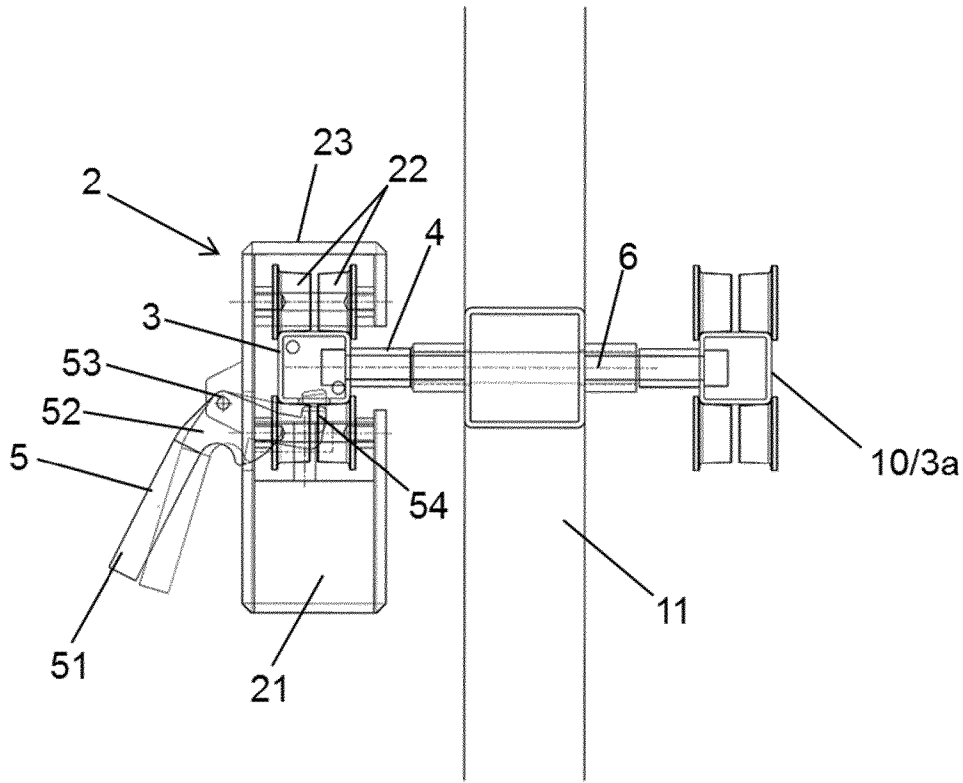

Fig. 2

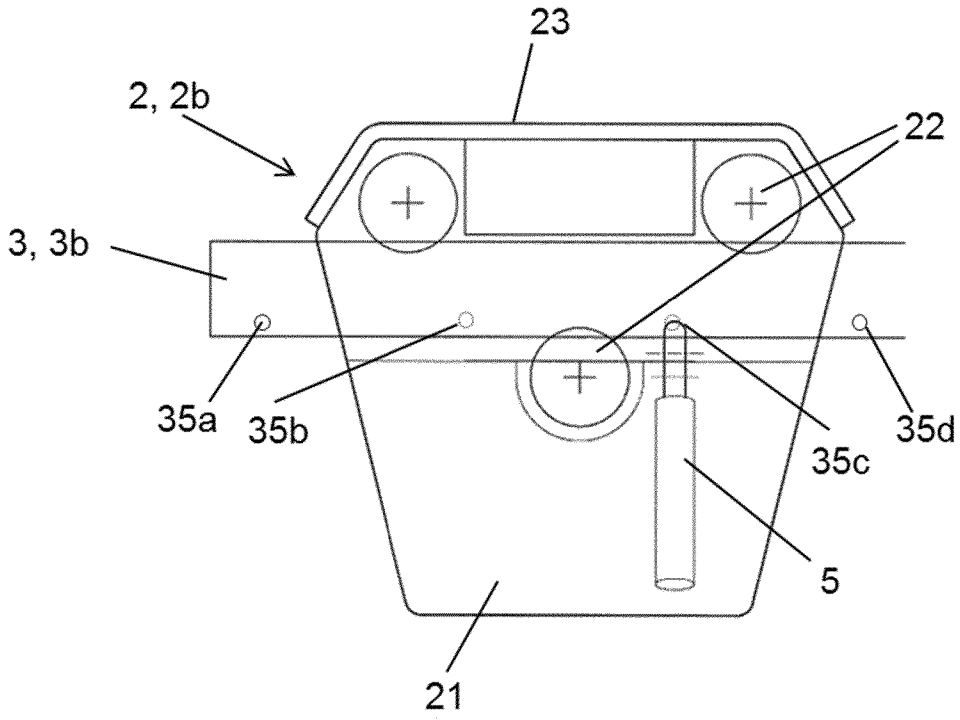

Fig. 3