

PORTAL CRANE FOR INTERVENTIONS

The invention refers to a portal crane for interventions, which can work autonomously as an electric vehicle, gantry crane, domed work area or folded within specific overall dimensions for road transportation; all functions are provided by the invention-related mechanisms designed for excellent performance outside specifically arranged areas, under harsh weather conditions; it can be used for rapid interventions on heavy equipment or vehicles of any nature, confined at the work sites because of accidental failure, or in heavy machinery and vehicle parks for the handling of sub-assemblies, including transportation for repairs. It can also be used as lifting and transport means in factory sheds not provided with a gantry crane.

Currently, the majority of gantry cranes are of self propelling type which, in very few cases only, can be equipped with wheel and tires steering system, and all lifting mechanisms are fitted to the outer side of the cantilever, based on a wrapped-around –the-drum system driven by an electric motor through a gear reducer; the crane is kept in place under load by means of the brakes; the CN200951934, CN201817210, EP1873112 patents are known as being specific technical solutions for portal cranes used for certain products.

The disadvantages of the current systems arise from the low versatility of portal cranes which, in almost all cases, can perform lifting and transport function strictly in a limited area determined by the distance between the supporting foots; they can only operate on suitably prepared areas, that is on runways or concrete platforms, all their mechanisms being exposed to harsh weather conditions, unprotected from residues and material deposits.

This invention cancels the disadvantages listed above by means of a new concept of lifting and transport equipment, to be used outdoors, as an alternative to the pair of machines employed up to now: the crane for lifting and forklift for transportation; to

achieve this goal, the portal crane for interventions has been designed with a folding steel portal frame equipped with specific mechanisms which allows it to function as an autonomous electric vehicle, gantry crane, domed work area, with the possibility of folding the entire unit for road transportation, all of which has been designed to output excellent performance outside specifically prepared areas and under harsh weather conditions.

As regards the versatile operation of the equipment we highlight that:

- the metallic folding portable structure consists of a rectangular pipe-type cantilever, a fork-foot and pole-foot; to fulfil the folding function the fork foot is fixed against the cantilever by means of a hinge, the front pole-foot is fixed to cantilever with a hinge; latching in the open position is obtained through a locking mechanism; the folding / unfolding action is provided a driving mechanism that consists of a hoist cable passed over a back-travel pulley and fixed through the eyelets on the foot;

- the autonomous electric vehicle is obtained by providing the metal structure with two drive pulleys fitted on the fork foot and a double-drive wheel on the pole-foot, all enabled by servo disc motor driven by a command and control unit, powered by an autonomous power source; as regards the operation position, the axis of the wheel and double-drive wheel are fixed parallel to the cantilever, their contact with the ground is arranged in an isosceles triangle pointing the double-drive wheel; the cinematic trajectory is obtained by performing swing motions, by controlling the speed rotation of the servo disc motor, which generates the rotation toward an instant centre of rotation positioned on a line segment that begins at half the height of the isosceles triangle, passes through the ground contact of the double-drive wheel and goes on towards infinity;

- the portal crane is powered by an independent source driven by a control and command system; it gets formed by providing the metallic structure with a single cable fixed to the eyelets at the cantilever ends; part of the cable is positioned beneath the cantilever and, along with the translation motion mechanism, they support the hook and enables it to get in motion beneath the cantilever; the other cable side stays inside the cantilever as part of a lifting mechanism which varies the free length of the cable and determines its vertical motion; the translation motion mechanism covers the outer part of

the cantilever, it rests on two rollers which, on one side sustain the two back-travel pulleys of the hook cable and, on the other, sustain the servo disc motor with end pinion geared with a rack; the lifting mechanism consist on the one hand, of the special nut provided on the side with two symmetrical cable pulley and on the front side with a rotation-blocking plate and is linearly driven by a ball screw controlled by an servo disc motor and, on the other hand, from a back-travel pulley and a cable entry pulley;

- the domed work area has a stiffening frame part of the metallic structure, and is consider as being a fix element on which, on the left and right side, it gets fixed a fan-shaped folding dome.

The advantages offered by the portal crane for interventions, as per the invention, are the following:

- fulfils the functions of lifting and transportation with the possibility to move on raw surfaces and under harsh weather conditions; it can successfully replace the crane and forklift tandem, with the advantage of a domed work area for work-related activities;

-simple design of the mechanism able to reach any trajectory, construction simple design of lifting mechanism and translation motion mechanism;

-all the mechanisms that make up the portal crane for harsh working conditions are completely insulated from the outside environment, advantage that enables excellent operation despite these conditions.

Hereafter it is given an example of the invention according to figures fig.1, fig 2, fig 3, fig 4, fig 5, fig 6, which represent:

fig 1: folded portal crane for interventions;

fig. 2: construction details of the metallic folding portable structure;

fig. 3: details regarding the autonomous electric vehicle structure;

fig. 4: constructive details of the translation motion mechanism;

fig 5: constructive details of the lifting mechanism;

fig. 6: constructive details of the domed work area.

For better clarity and understanding of the invention content, concepts, phenomena and objects in the state of the art will not be explained nor designated as follows: rectangular pipe, folding/unfolding, wheels axis, wheel axis, parallelism, contact

with the ground, isosceles triangle, pivoting, rotation per minute, rotation, endless, steering, metal structure, fixed element, profile, algorithm.

Regarding the design, the portal crane for interventions, with reference to fig. 1 ... fig 6, is a metallic structure (A) in the form of a folding portal, equipped with specific invention means that enables it to operate as an autonomous electric vehicle (B) as portal crane (C) and as domed work area (D), all designed for excellent performances outside specifically arranged areas and under harsh weather conditions.

The folding portable metallic structure (A) consists of a cantilever (a), on which there can be distinguished the rectangular pipe-like cantilever (1), leaning the ends on a short beam (2) and a long beam (3) closed at the ends, with a cover (4) and the cover (5) and stiffened on the outside with an upper frame (6), equipped with two lifting eyelets (7) and, on one side of the fork-foot (b), consisting of the beam (8) with two fixing ends (9), stiffened with an outer beam (10), positioned in the continuation of the upper frame (6) and, on the other side, the pole-foot (c) with the fixing ends (11), stiffened with a beam (12), positioned as well in the continuation of the upper frame (6); to fulfil the folding function the fork foot (b) is fixed against the short beam (2) by means of a hinge (13), the pole-foot (c) is fixed against the long beam (3) with the hinge (13); latching in the open position is obtained through a locking mechanism (d) between the upper frame (6) and the beam (10), respectively beam (12), through interlocking eyelets (14) and crossing bolt (15); the folding / unfolding action is made by means of a driving mechanism (e) which consist of an electric block and tackle (16), positioned on the beam (2), respectively beam (3) with the cable (17), passed over a back-travel pulley (18), connected to the cantilever (a) fixed under through eyelet (19) on the fork-foot (b), respectively the pole-foot (c).

The autonomous electric vehicle (B) is obtained by providing the metal structure (A) with two drive pulleys (20) fitted on ends (9) of the fork foot (b) and a double-drive wheel (21) on the end (11) of the pole-foot (c), all enabled by servo disc motor (22) driven by a command and control unit (23), powered by an autonomous power source (24) consisting of an electrical generator or a batteries group; as regards the operation position, the axis of the wheels (20) and of the wheel (21) are fixed parallel to the

cantilever (a), their contact with the ground is arranged in an isosceles triangle pointing the double-drive wheel (21); from the cinematic viewpoint, the trajectory is obtained by performing swing motions, controlling the speed rotation of the servo disc motor (22) which generates the rotation toward an instant centre of rotation (25) positioned on a line segment (26) that begins at half the height of the isosceles triangle, passes through the ground contact of the double-drive wheel (21) and goes on towards infinity.

The portal crane (C) is powered by the independent source (24) and steered by a control and command system (23); is made up by providing the metallic structure (A) with a single cable (27) fixed at its ends with eyelets (28) on the cover (4), respectively the long beam (3); one part of the cable (27) is positioned beneath the cantilever (1) and, along with the translation motion mechanism (f), they support the hook (29) and enables it to get in motion beneath the cantilever (1); the other cable (27) part stays inside the cantilever (1) as part of a lifting mechanism (g) which varies the free length of the cable (27) and determines its vertical motion of the hook (29).

The translation motion mechanism (f) is a metallic construction which covers the outer part of the cantilever (1), it rests on two rollers (30) and which, on one side, sustains the operation position, the two back-travel pulleys (31), the two back-travel pulleys of the cable (27) that bears the hook (29) and, on the other side, sustain the servo disc motor (32) with end pinion (33) geared with a rack (34) positioned beneath the cantilever (1).

The lifting mechanism (g) consist on the one hand, of the special nut (35) provided on the side with two symmetrical cable pulley (36) and on the front side with a rotation-blocking plate (37) and is linearly driven by a ball screw (38) controlled by an servo disc motor (39), with stress release on the cover (5) and, on the other hand, from a back-travel pulley (40) and a cable entry pulley (41), both fixed with a fork (42) to the cover (4).

The domed work area (D) is provided with a stiffening frame (43) which consist of an upper frame (6), the beam (10) and beam (12) considered as being part of the metallic structure on which, on the left and right side, it gets fixed a fan-shaped folding dome (44), each being made up of, on one side, the ribs (45), which opens in a fan and

two joints (46), fastened at the base of the beam (10), respectively, of the beam (12) and, on the other side, of an easy-folding membrane (47); the folding domes (44) open and close by means of standardized actuator mechanisms.

From the functional viewpoint, the portal crane for interventions fulfils two different and autonomous functions: the function of electric vehicle (B) through the specific machineries for this function, and the function of gantry crane (C) also through the specific machineries, both machinery categories are positioned on a command and control unit (23) that sends the commands via wires or wireless.

The reaching of any trajectory on a given surface is achieved by varying the rotations per minute of the servo disc motor (22) enabled by the command and control unit (23) on the basis of an algorithm, and thus being obtained motions on all trajectories, including straight line.

The lifting mechanism (g) fulfils the motion function on the vertical axis of the hook (29) by pulling the cable (27), between the special nut (35) with cable pulley (36), driven into motion by the screw (38) in connection with the servo disc motor (39) and the wheels unit, the back-travel pulley (40) and the cable entry pulley (41), fixed on the cover (4).

The translation motion mechanism (f) which has the function of moving the hook (29) along the cantilever (1), its shifting being enabled by the servo disc motor (32) with end pinion (33) geared with a rack (34).

CLAIMS

R1. The portal crane for interventions, with reference to fig. 1 ... fig n, is a metallic structure (A) in the form of a folding portal, equipped with specific invention means that enables it to operate as an autonomous electric vehicle (B) as portal crane (C) and the domed work area (D), all designed for excellent performances outside specifically arranged areas and under harsh weather conditions.

R2. The folding portable metallic structure (A), as per the claim 1, characterized by the fact that consists of a cantilever (a), on which there can be distinguished the rectangular pipe-like cantilever (1), leaning the ends on a short beam (2) and a long beam (3) closed at the ends, with a cover (4) and the cover (5) and stiffened on the outside with a upper frame (6), equipped with two lifting eyelets (7) and, on one side the fork-foot (b), consisting the beam (8) with two fixing ends (9), stiffened with an outer beam (10), positioned in the continuation of the upper frame (6) and, on the other side, the pole-foot (c) with the fixing ends (11), stiffened with a beam (12), positioned as well in the continuation of the upper frame (6); to fulfil the folding function the fork foot (b) is fixed against the short beam (2) by means of a hinge (13), the pole-foot (c) is fixed against the long beam (3) with the hinge (13); latching in the open position is obtained through a locking mechanism (d) between the upper frame (6) and the beam (10), respectively beam (12), through interlocking eyelets (14) and crossing bolt (15); the folding / unfolding action is made by means of a driving mechanism (e) which consist of an electric block and tackle (16), positioned on the beam (2), respectively beam (3) with the cable(17), passed over a back-travel pulley (18), connected to the cantilever (a) fixed under through eyelet (19) on the fork-foot (b), respectively the pole-foot (c)

R3. Autonomous electric vehicle (B) characterized by the fact that it is obtained by providing the metal structure (A) with two drive pulleys (20) fitted on ends (9) of the fork foot (b) and a double-drive wheel (21) on the end (11) of the pole-foot (c), all enabled by servo disc motor (22) driven by a command and control unit (23), powered by an autonomous power source (24) of electrical generator or batteries group type; as regards the operation position, the axis of the wheels (20) and of the wheel (21) are fixed parallel to the cantilever (a), their contact with the ground

is arranged in an isosceles triangle pointing the double-drive wheel (21); the cinematic trajectory is obtained by performing swing motions, by controlling the speed rotation of the servo disc motor (22) which generates the rotation toward an instant centre of rotation (25) positioned on a line segment (26) that begins at half the height of the isosceles triangle, passes through the ground contact of the double-drive wheel (21) and goes on towards infinity

R4. The portal crane (C), as per the claim 1, is powered by an independent source (24) and steer by a control and command system (23); is made up by providing the metallic structure (A) with a single cable (27) fixed at its ends with eyelets (28) on the cover (4), respectively the long beam (3); one part of the cable (27) parts is positioned beneath the cantilever (1) and, along with the translation motion mechanism (f), they support the hook (29) and enables it to get in motion beneath the cantilever (1); the other cable (27) part is positioned inside the cantilever (1) as part of a lifting mechanism (g) which varies the free length of the cable (27) and determines its vertical motion of the hook (29).

R5. The translation motion mechanism (f), as per the claim 1 and 4, characterized by the fact that it represents a metallic construction which covers the outer part of the cantilever (1), it rests on two rollers (30) and which, on one side, sustains the operation position, the two back-travel pulleys (31), the two back-travel pulleys of the cable (27) that bears the hook (29) and, on the other side, sustain the servo disc motor (32) with end pinion (33) geared with a rack (34) positioned beneath the cantilever (1).

R6. The lifting mechanism (g), as per the claim 1 and 4 and characterized by the fact that it consist on the one hand, of the special nut (35) provided on the side with two symmetrical cable pulleys (36) and on the front side with a rotation-blocking plate (37) and is linearly driven by a ball screw (38) controlled by an servo disc motor (39), with stress release on the cover 5 and, on the other hand, from a back-travel pulley (40) and a cable entry pulley (41), both fixed with a fork (42) to the cover (4).

R7. The domed work area (D), according to the claim 1, characterized by the fact that it is

provided with a stiffening frame (43) which consist of an upper frame (6), the beam (10) and beam (12) is considered as being part of the metallic structure on which, on the left and right side, it gets fixed a fan-shaped folding dome (44), each being made up of, on one side, the ribs (45), with opens in a fan and two joints (46), fastened at the base of the beam (10), respectively, of the beam (12) and, on the other side, of an easy-folding membrane (47); the folding domes (44) open and close singularly by means of standardized actuator mechanisms.

ABSTRACT

The portal crane for interventions, with reference to fig. 1 ... fig n, is a metallic structure (A) in the form of folding portal, equipped with specific invention means that enable sit to operate as an autonomous electric vehicle (B) as portal crane (C) and the domed work area (D), all designed for excellent performances outside specifically arranged areas and under harsh weather conditions.

Fig. 2 to be published here.

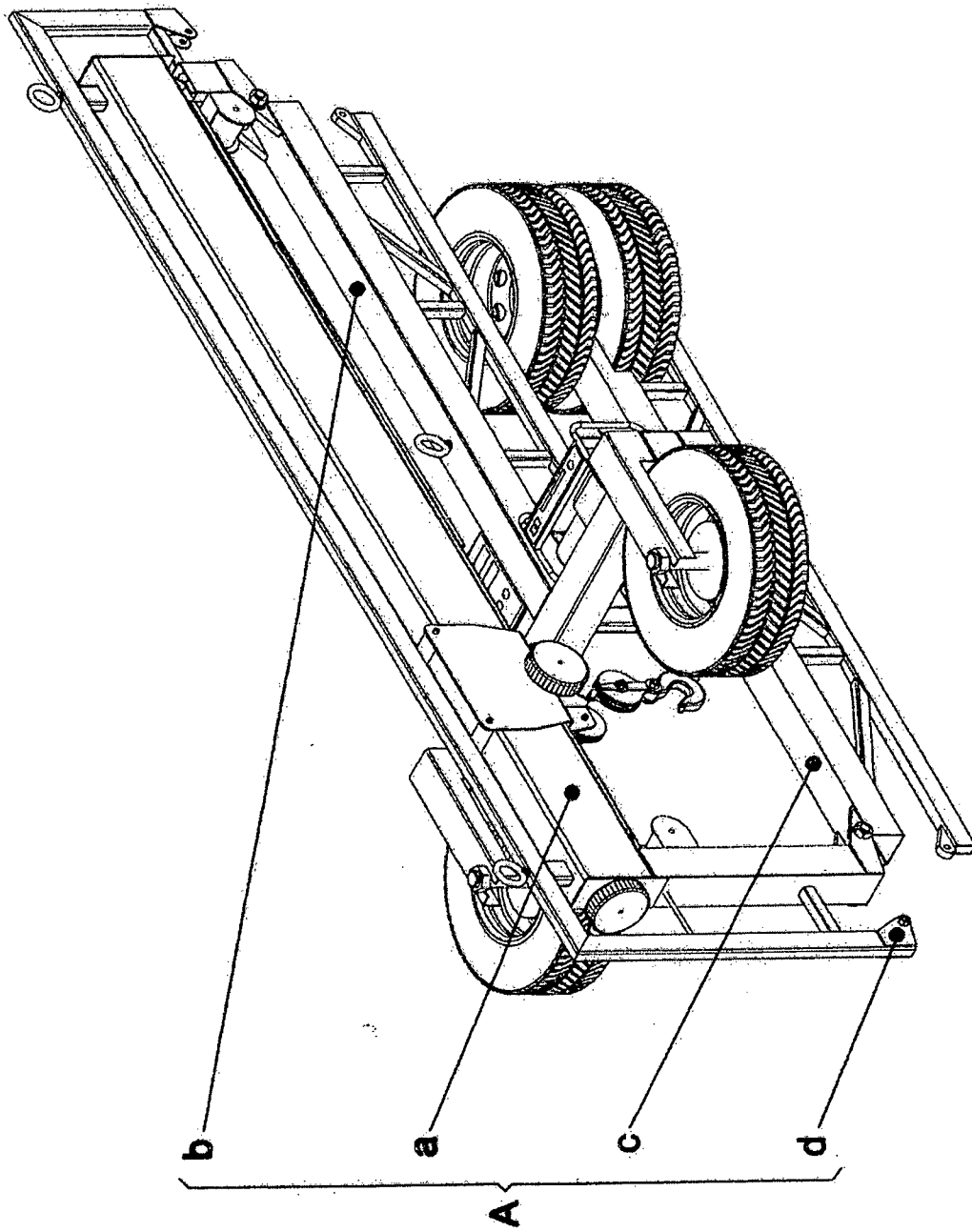

Fig. 1

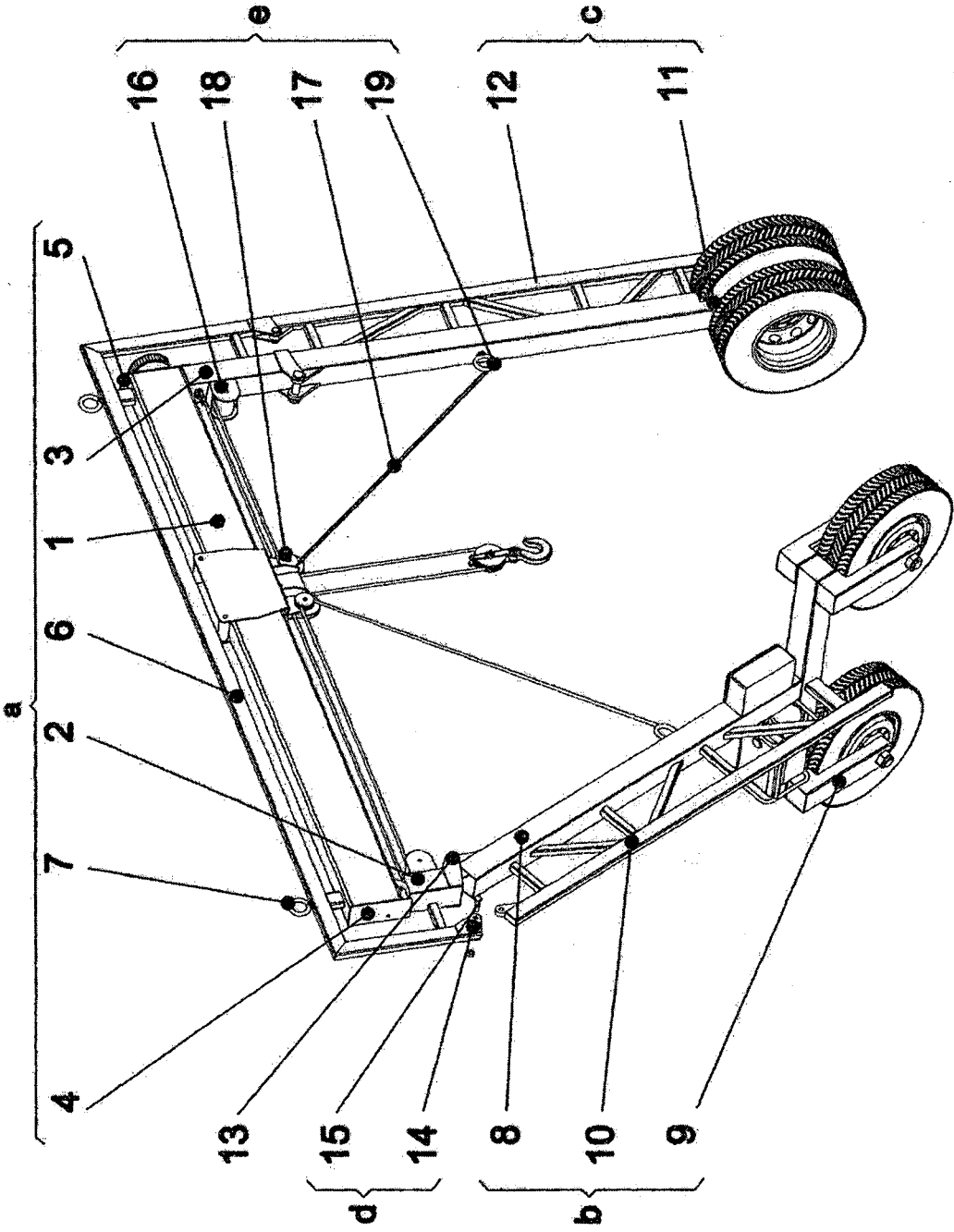

Fig. 2

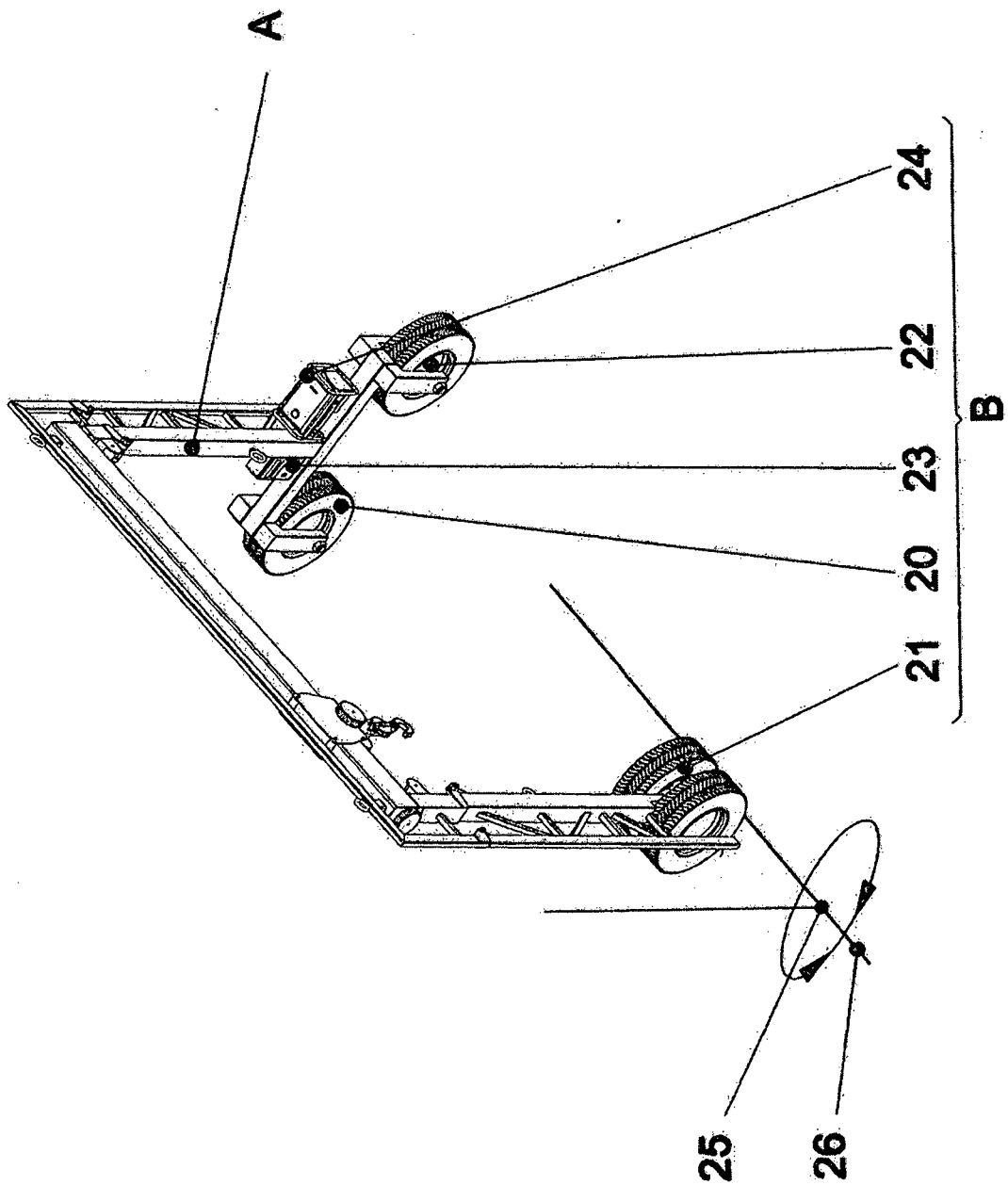

Fig. 3

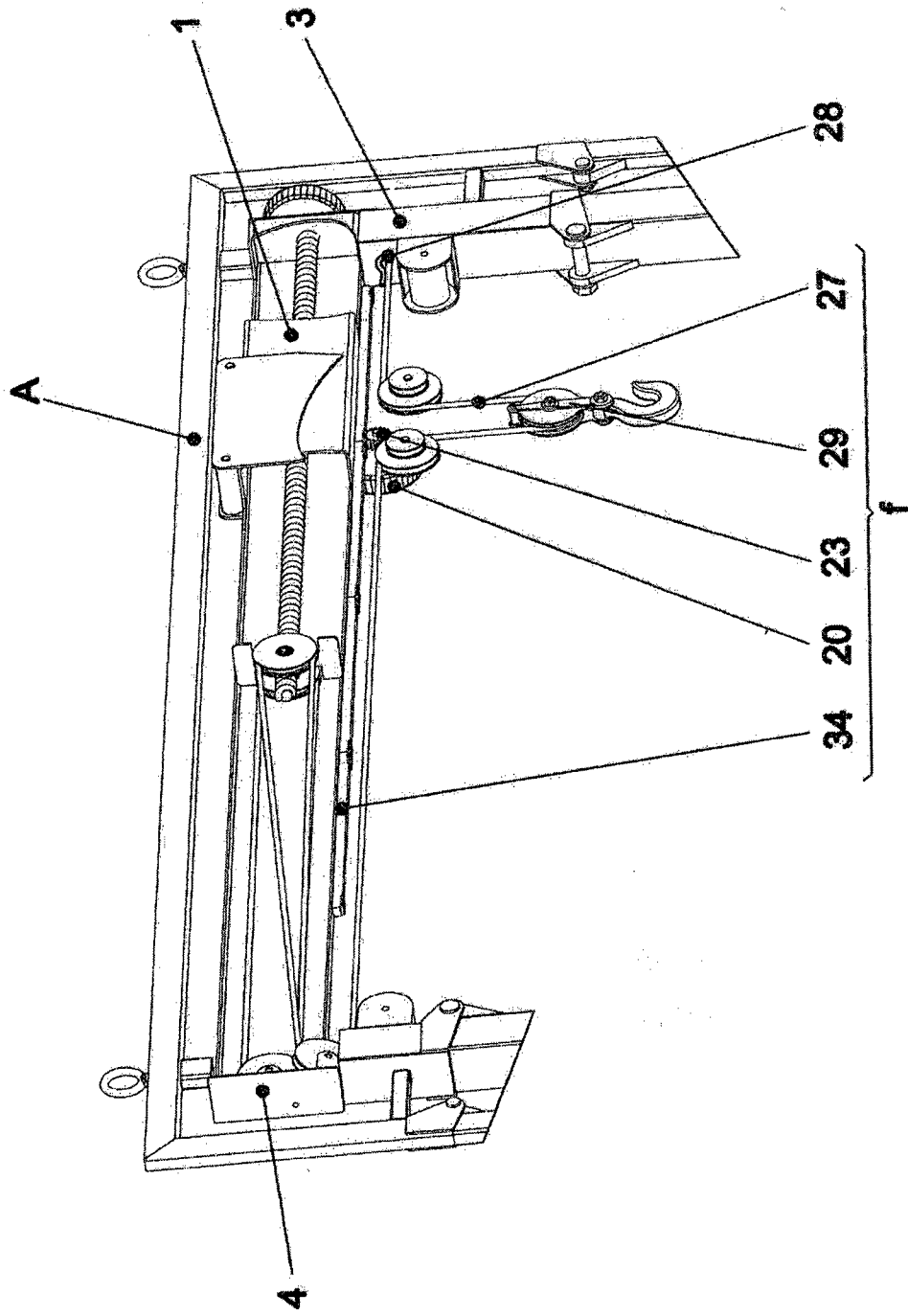

Fig. 4

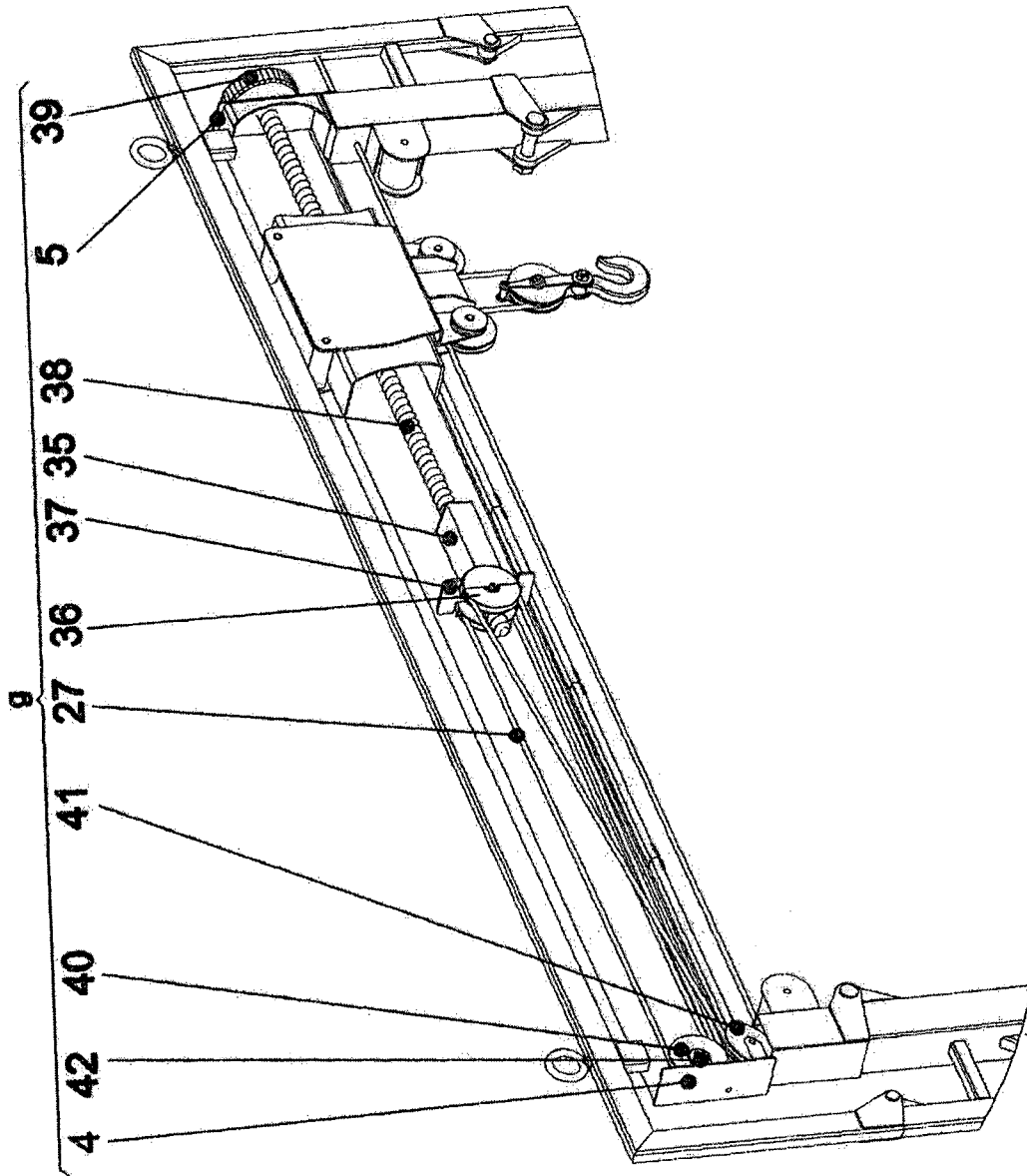

Fig. 5

