

DOCUMENT MADE AVAILABLE UNDER THE PATENT COOPERATION TREATY (PCT)

International application number:	PCT/EP2013/066365
International filing date:	05 August 2013 (05.08.2013)
Document type:	Certified copy of priority document
Document details:	Country/Office: DK
	Number: PA 2012 00492
	Filing date: 07 August 2012 (07.08.2012)
Date of receipt at the International Bureau:	19 August 2013 (19.08.2013)

Remark: Priority document submitted or transmitted to the International Bureau in compliance with Rule 17.1(a),(b) or (b-bis)

EP 13 / 66365



Kongeriget Danmark

Patent application No.: PA 2012 00492
Date of filing: 7 August 2012
Applicant: Cedrex A/S
(Name and address) Notgangen 3
DK-2690 Karlslunde
Denmark

Title: Test Tube Capping and De-Capping Apparatus

IPC: B 67 B 7/18; B 01 L 3/00; G 01 N 35/02; G 01 N 35/10

This is to certify that the attached documents are exact copies of the above mentioned patent application as originally filed.

Patent- og Varemærkestyrelsen
Økonomi- og Erhvervsministeriet

6 August 2013

Handwritten signature of Maria Limneos in black ink.
Maria Limneos



TEST TUBE CAPPING AND DE-CAPPING APPARATUSFIELD

5

The present invention relates to a capping and de-capping device and a method for attaching and removing caps from tubes, and, more particularly, a device and method for removing screw-threaded caps from test tubes such as
10 micro tubes used in laboratories or micro-biological systems.

BACKGROUND

15 High value biological samples are often stored and processed using so-called SBS format racks containing a plurality of test tubes. Such racks may contain, for example, 96 test tubes in an array of 8 by 12 apertures designed to hold the tubes securely. The test tubes and
20 their contents may be maneuvered in a processing system, for example between a cold store and various processing stations and may be required to be filled (partly or fully) or processed simultaneously or individually.

25 Conventionally, capping and de-capping has either been carried out by hand or else by means of a capping and de-capping unit one test tube at a time, either while they are still held in the rack or after they have been separated from the rack. This is not only tedious
30 (particularly in the case of manual capping and de-capping), but also slow as it is usual for multiple tubes to require processing in the same way at the same time.

It is known to provide a linear array of capping and de-capping units to allow for the capping and de-capping of a row of tubes, but such systems have been bulky as a result of the dimensions of the drive mechanisms for the capping and de-capping units, the close spacing of the test tubes requiring the drive mechanisms of the capping and de-capping units to be remote from the capping and de-capping heads and disposed over a larger footprint than the rack because of their size.

10

EP 1882949 disclose a capping and de-capping apparatus having a test tube rack support for supporting a rack containing a plurality of capped test tubes in a given position. A head unit supports a two-dimensional array of capping and de-capping spindles, each of which includes a clutch and a capping and de-capping spigot or socket, the spindles being aligned with the test tube positions defined in the rack. A drive mechanism moves the tubes and the head unit relatively towards and away from one another in use, when a rack containing capped test tubes is disposed in the rack support, causing engagement and disengagement of the spigots or sockets with and from the tube caps. A spindle drive system provides simultaneous rotation of the spigots or sockets together after engagement with the caps, either to attach caps to the tubes or detach caps from the tubes. Ejection of the caps from the spigots is caused by moving an external net in the opposite direction to the spindle translational movement thereby detaching all sockets from all caps in one movement.

30

SUMMARY

On this background the present applicants realized the need for a simple and customizable apparatus for capping and de-capping one or more test tubes held within the tight confinement of standard laboratory test tube racks; which will permit each tube to be individually capped and de-capped for some laboratory uses while retaining the ability to cap or de-cap all tubes within the rack at the same time for other uses.

This object is achieved by providing a apparatus for capping and de-capping test tubes having one or more capping and de-capping grippers equipped with a capping and de-capping socket unit wherein said one or more grippers each are configured with an ejector pin moveably arranged within said one or more grippers and wherein said ejector pin may perform a translational movement relative to the said one or more grippers effecting the release from the socket unit of a cap retained by the socket unit.

This object is further achieved by providing a capping and de-capping gripper equipped with a capping and de-capping socket unit said gripper and socket unit so arranged as to permit said ejector pin to perform a translational movement relative to the said gripper and socket unit effecting the release from the socket unit of a cap retained by the socket unit.

30

This object is further achieved by providing said ejector pin with an actuator unit capable of rotating said ejector pin.

This object is further achieved by providing said capping and de-capping socket unit with a socket for grabbing and retaining a test tube cap adaptable to a plurality of different laboratory test tube systems.

5

This object is further achieved by combining the above apparatus with a programmable logic controller, microprocessor, or computer application, either internal or external to said apparatus, for controlling the
10 movement of the gripper units and ejector pins individually, in subgroups of the total array of gripper units and ejector pins, or the totality of the gripper units and ejector pins and by providing a user interface permitting the user to select which gripper or grippers
15 within the array of grippers that shall engage a corresponding tube within the rack.

Further objects, features, advantages, and properties of the apparatus and method according to the present
20 disclosure will become apparent from the detailed description.

BRIEF DESCRIPTION OF THE DRAWINGS

25 In the following detailed portion of the present description, the teachings of the present document will be explained in more detail with reference to the exemplary embodiments shown in the drawings, in which:

30 Figures 1a and 1b present two different views of the capping and de-capping apparatus according to the teachings herein. In Figure 1a the combination of the apparatus according to the present invention with an

external control unit is exemplarily shown without this embodiment being thereby considered preferred,

Figure 2 is a view of a capping and de-capping gripper
5 according to the teachings herein,

Figure 3a is an exemplary view of three of the capping and de-capping socket units according to the teachings herein, and

10

Figure 3b is an exemplary view of a capping and de-capping socket unit combined with an external spring encircling the capping and de-capping socket.

15 DETAILED DESCRIPTION

In the following detailed description the capping and de-capping apparatus, the capping and de-capping gripper, the capping and de-capping socket unit and the
20 application for controlling the capping and de-capping grippers individually are described in detail with reference to the exemplary embodiments.

An embodiment of the capping and de-capping apparatus 100
25 according to the invention is depicted in detail in Figure 1a and 1b. In Figure 1a an external control unit 160 is shown for illustrative purposes. As is clear to the skilled person, the control unit 160 can be external to the apparatus 100 for some purposes or can be
30 integrated into the apparatus for other purposes. Further the connection between the control unit 160 and the apparatus 100 may be a cable as shown in the figure or could be a WIFI-signal or other like options depending on

the skilled person's choice, such choices being considered trivial in a modern laboratory setting.

The capping and de-capping apparatus 100 is equipped with a rack support 110 for supporting a tube rack 111, preferably a test tube rack, for containing in at least one given position within the rack 111 at least one tube 112, preferably a test tube, fitted to receive and/or dispose of a cap 113, preferably a screw cap.

10 The capping and de-capping apparatus 100 is further equipped with a head unit 120 supporting a two-dimensional array 121 (in the present exemplary embodiment a 6 * 8 array) of capping and de-capping grippers 122, each capping and de-capping gripper 122 including a capping and de-capping socket unit 123 15 capable of engaging and retaining a cap, the capping and de-capping grippers 122 being aligned with the tube positions within the rack 111.

20 The capping and de-capping apparatus 100 is also equipped with a drive system 130 for moving the rack support 110 and head unit 120 relatively towards and away from one another in use, when a rack 111 containing at least one tube 112 is disposed in the rack support 110, to cause 25 engagement and disengagement of at least one capping and de-capping socket unit 123 with and from the at least one tube 112.

30 The capping and de-capping apparatus 100 is further equipped with a drive system 140 for rotating at least one capping and de-capping gripper 122 and the capping and de-capping socket unit 123 attached thereto, said rotation of the capping and de-capping socket unit 123, after engagement of the at least one capping and de-

capping socket unit 123 with at least one cap 113, can cause either attachment of the at least one cap 113 to the at least one tube 112 within the rack 111 when the at least one capping and de-capping gripper 122 rotate in
5 the one direction or detachment of the at least one cap 113 from the at least one tube 112 when the at least one capping and de-capping gripper 122 rotate in the other direction.

10 Further, the capping and de-capping apparatus 100 is further equipped with a drive system 150 internal to the head unit 120, permitting a first attachment body 151 and a second attachment body 152 to perform a movement towards and away from each other independently of the
15 movement of the head unit 120 when moved by the drive system 150.

Finally, the capping and de-capping apparatus 100 is further equipped with a control unit 160, said control
20 unit being preferably a programmable logic controller, a microprocessor, or a computer application, said control unit 160 being either internal or external to said apparatus 100, for controlling the movement, both translational and rotational, of the gripper units and
25 ejector pins individually, in subgroups of the total array of gripper units and ejector pins, or the totality of the gripper units and ejector pins and by providing a user interface permitting the user to select which gripper or grippers within the array of grippers that
30 shall engage a corresponding tube within the rack. In a preferred embodiment the control unit 160 is equipped with means 270 for measuring the torque associated with each rotating gripper, preferably by measuring the current supplied to the drive system 140 needed to

effectuate a continued rotation of at least one gripper, and means 280 for terminating the rotation of the at least one gripper if a given threshold value is exceeded.

5 An embodiment of the capping and de-capping gripper 122 according to the invention is depicted in detail in Figure 2.

The capping and de-capping gripper 122 comprises a
10 capping and de-capping socket unit 123 capable of engaging and retaining a cap, said capping and de-capping socket unit 123 having a through going passage 211, an ejector pin guide 220 also having a through going passage 221, and an ejector pin 230, and wherein the socket unit
15 123 and the ejector pin guide 220 are so arranged to permit said ejector pin 230 to perform a translational movement within said socket unit 123 and said ejector pin guide 220.

20 The ejector pin 230 is stationary with respect to the above mentioned first attachment body 151, for example because it is attached to said first attachment body 151. Likewise the ejector pin guide 220 is stationary with respect to said second attachment body 152, for example
25 because it is attached to said second attachment body 152. Accordingly, upon the activation of the drive system 150, said translational movement of said ejector pin 230 within said socket unit 123 and said ejector pin guide 220 can be effectuated.

30

While it is possible for said capping and de-capping socket unit 123 and said ejector pin guide to be manufactured in one piece, it is preferred that they are not. Therefore in a preferred embodiment the capping and

de-capping socket unit 123 is attachable and detachable to said ejector pin guide 220 such that when said capping and de-capping socket unit 123 is attached to said ejector pin guide 220, said ejector pin 230 may perform a translational movement within the said ejector pin guide 220 attached to the said capping and de-capping socket unit 123.

The drive system 140 for rotating the ejector pin 230 comprises a plurality of actuator units 240 coupled to said ejector pin 230, each actuator unit 240 comprising an actuator 250, preferably an electro motor, mechanically coupled to said ejector pin 230. In a preferred embodiment of the actuator unit 240, said actuator 250 is mechanically coupled to said ejector pin 230 by means of a gear 260. Additionally the drive system 140 may comprise internal or external means 270 for sensing the torque on said ejector pin 230, e.g. if the actuator 250 is an electro motor, by detecting a change in the current supplied to the actuator 250, and internal or external means 280 for halting the actuator movement if a certain threshold torque is exceeded. Preferably, however, the means 270 for sensing torque and the means 280 for halting the actuator movement are associated with the control unit 160.

In this further embodiment wherein said ejector pin 230 is rotated by said actuator unit 240, preferably in the configuration of an actuator 250 coupled to a gear 260, said ejector pin 230 includes means 231 for transferring the rotational movement created by said actuator unit 240 to said ejector pin guide 220 or said capping and de-capping socket unit 123. In one embodiment said means 231 for transferring the rotational movement of said ejector

pin 230 to said ejector pin guide 220 consists in a pin 232 protruding from said ejector pin 230 at a right angle and into a longitudinal groove 221 in the ejector pin guide 220.

5

In a further embodiment the ejector pin guide 220 further comprises means 222 for attaching a capping and de-capping socket unit 123 to said ejector pin guide 220. In a preferred embodiment the means 222 for attaching a capping and de-capping socket unit 123 further comprises a biasing means 223, preferably a coil spring.

An embodiment of the capping and de-capping socket unit 123 according to the invention is depicted in detail in Figure 3.

15

A capping and de-capping socket unit 123 capable of engaging and retaining a cap 113, preferably a test tube cap, for use with a capping and de-capping gripper 122 having a gripper connector 310 for attaching and detaching to said capping and de-capping gripper 122, or in the most preferred embodiment, to said ejection pin guide 220, is described in Figure 3. The less preferred embodiment of a capping and de-capping socket unit permanently attached to said ejection pin guide is not shown in the figure. It is however to be understood, and such is also clear from the contents of Figure 3, that the socket unit 123 is so conceived that the manner of which it engages and disengages a cap is independent of how it attaches to the ejector pin guide 220, and whether this attachment is permanent or not.

25

30

Both in the embodiment of a socket unit 213 permanently attached to said ejector pin guide 220 or in the

preferred embodiment of a socket unit 123 which is attachable and detachable to said ejector pin guide 220, said socket unit 123 comprises a socket 320 for connecting to a cap, preferably a test tube cap, and even
5 more preferably a screw cap for a test tube. In the preferred embodiment of an attachable or detachable socket unit 123, the socket unit 123 may further comprise a mechanical connection 330 between said gripper connector 310 and said socket 320, said gripper connector
10 310, said socket 320 and said optional mechanical connection 330 each having a through going passage 211.

The socket unit 123 and ejector pin guide 220 are preferably manufactured from a plastics material,
15 preferably in a molding process such as injection molding. When the socket unit is permanently attached to said ejector pin guide 220, also this assembly may be manufactured from a plastics material, preferably in a molding process such as injection molding. When the
20 socket unit 123 is not permanently attached to said ejector pin guide 220, said ejector pin guide 220 may also be manufactured from a material different from plastics, including metals such as but not limited to, aluminum or stainless steel, and using other means for
25 manufacturing of said ejector pin guide 220 than injection molding.

Known plastics materials which are useful in the manufacture of the socket unit 123 and ejector pin guide
30 220 can be PEEK (Polyetheretherketone) or POM (Polyoximethylene) but also other plastics materials will be known to the skilled person.

The socket 320 is described in further detail in Figures 3a and b. A variety of test tube caps are known in the art and it is a further aim of the present invention to enable the attachment of the socket unit 123 in a simple
5 manner to the test tube caps by applying a simple and adaptable method of attachment.

To this purpose each socket 320 is equipped with at least one friction pin 321, but preferably with a plurality of
10 friction pins 321. A socket 320 according to the invention further has a through going passage 211, to permit the passage of the said ejector pin 230 through the said socket 320.

15 A socket 320 according to the present invention is so manufactured that upon engagement with a test tube cap 113, the socket 320 is squeezed over the test tube cap 113 and/or, where the test tube cap 113 contains a groove for inserting a socket into said groove, the socket 320
20 may further be inserted into said groove. Independently of the method of attachment for use with a specific test tube cap, the at least one friction pin 321 ensures a tight contact between the socket 320 and the test tube cap 113 such that when the capping and de-capping gripper
25 122 is undergoing a movement, either a translation or a translation combined with a rotation, the cap 113 is retained within the socket 320 until ejected using the ejector pin 230.

30 In one embodiment of the socket 320, for use with a test tube cap 113 that does not have a groove into which a socket can be inserted, the socket 320 has an inner geometrical shape that matches the outer geometrical shape of the test tube cap 113, that it is about to

engage with the at least one, but preferably a plurality of friction pins 321 arranged on the inner surface of the socket, such that the pins protrude towards the center of the ejector pin guide 211.

5

In another embodiment of the socket 320, for use with a cap 113 that does have a groove into which a socket can be inserted, the socket 320 has at least one, but preferably a plurality of friction pins 321 arranged on the surface of said socket 320 facing away from the said ejector pin guide 211.

10

In a further embodiment, for use with some test tube caps, it is preferable to combine the two previous modes of arranging the at least one friction pin 321.

15

Figure 3b shows an improvement of the socket unit 123 which offers enhanced attachment to a test tube cap 113, this being particularly useful when said cap is damaged or worn, wherein a spring 340 is placed externally to the socket 320, encircling said socket, thereby providing a compression force towards the center of the socket 320 and thus increasing the friction on said cap 113 exerted by the at least one friction pin 321. The shape of the spring is determined by shape of the socket 320 to which it is external. The spring 340 may be made from any elastic material, but preferentially it is made from an elastomer, such as (but not limited to) rubber or PVC, preferentially in the form of an O-ring, or circlips such as e.g. a metallic spring ring.

20

25

30

In operation, the head unit 120 is moved towards the rack support 110 by the drive system 130. A capping and de-capping gripper 122 engages an opposing cap 113 on an

opposing test tube 112 via the socket 320 on the socket unit 123. Disengagement of the cap 113 from the test tube 112 is brought about by the concerted movement of the drive system 130 moving now the head unit 120 away from
5 the rack support 110 and a rotational movement of the actuator unit 240 connected to said capping and de-capping gripper 122 in contact with said cap 113. Caps in contact with a capping and de-capping gripper 122 but not undergoing a rotation by the actuator unit 240 forming
10 part of such a capping and de-capping gripper 122 are not removed from their respective test tubes 112.

To attach a removed cap, the above procedure is reversed. It is stopped when the means 270 for sensing the torque
15 on the ejector pin registers that a certain threshold torque is exceeded. The tube 112 now having a cap has its cap ejected from the socket 320, by moving said tube 112 towards the ejector pin 230 by the drive mechanism 150, whereby the socket unit 123 and ejector pin guide 220 are
20 moved past that end of the ejector pin 230 that is in contact with the cap 113 and said cap is thereby released, freeing the capping and de-capping system 100 to perform a new cycle of capping and de-capping.

25 The term "comprising" as used in the claims does not exclude other elements or steps. The term "a" or "an" as used in the claims does not exclude a plurality. The controller may fulfill the functions of several means recited in the claims. The reference signs used in the
30 claims shall not be construed as limiting the scope.

Although the present invention has been described in detail for purpose of illustration, it is understood that such detail is solely for that purpose, and variations can be made therein by those skilled in the art without
5 departing from the scope of the invention.

CLAIMS:

1. A capping and de-capping apparatus (100) for capping
5 and de-capping capable tubes (112) disposed in a
rack (111) with a two dimensional array of apertures
for holding said tubes, said apparatus (100)
comprising:
- 10 - a rack support (110) for supporting said rack
(111),
- a head unit (120) supporting a two-dimensional
array (121) of capping and de-capping grippers
15 (122), each capping and de-capping gripper (122)
including a capping and de-capping socket unit
(123) configured for engaging and retaining a cap
(113), said capping and de-capping grippers (122)
being aligned with tube apertures defined by the
20 array in said rack (111),
- a drive mechanism (130) for moving the rack
support (110) and head unit (120) relatively
towards and away from one another, , to cause
25 engagement or disengagement of at least one
capping and de-capping socket unit (123) with or
from a cap (113) of at least one tube (112); and
- a drive system (140) for rotating at least one
30 capping and de-capping gripper (122) and the
capping and de-capping socket unit (123) attached
thereto, wherein rotation of the capping and de-
capping socket unit (123), after engagement of the
at least one capping and de-capping socket unit

(123) with at least one cap (113), causes attachment of the at least one cap (113) to the at least one tube (112) within the rack (111) when the at least one capping and de-capping gripper (122) rotates in one direction and causes detachment of the at least one cap (113) from the at least one tube (112) when the at least one capping and de-capping gripper (122) rotates in the opposite direction,

10 **characterized in that**

- the at least one capping and de-capping gripper (122) has a through going passage (221) extending through the at least one capping and de-capping gripper (122) and the capping and de-capping socket unit (123) attached thereto,
- an ejector pin (230) moveably arranged within said through going passage (221);
- and wherein said ejector pin (230) is configured to perform a translational movement relative to the at least one capping and de-capping gripper (122) and capping and de-capping socket unit (123) attached to said gripper (122) thereby effecting a release of a cap (113) retained within the capping and de-capping socket unit (123).

2. A capping and de-capping apparatus (100) according to claim 1 comprising a plurality of capping and de-capping grippers (122) each with a capping and de-capping socket unit (123) attached thereto so configured that each capping and de-capping gripper

(122) may engage and/or disengage a cap (113) independently.

- 5 3. A capping and de-capping apparatus (100) according to claim 1 or 2, configured such that each tube (112) received in said rack (111) can be capped and/or de-capped independently.
- 10 4. A capping and de-capping apparatus (100) according to any one of the claims 1 to 3 wherein said apparatus comprises a control unit (160) configured to control the operation of each of said capping and de-capping grippers (122) and each of said ejector pins (230) independently from one another.
- 15 5. A capping and de-capping apparatus (100) according to any one of the claims 1 to 4 wherein the said cap (113) is a screw cap.
- 20 6. The capping and de-capping apparatus (100) according to any one of the claims 1 to 5 further comprising a user interface associated with said control unit (160) and configured to permit a user to decide which capping and de-capping gripper (122) shall
- 25 engage and/or disengage a said tube (112) configured to receive and/or dispose of a cap (113) placed within said rack (111) at a position corresponding to the position of said capping and de-capping gripper (122) within said head unit (120).
- 30 7. A capping and de-capping gripper (122) comprising

- a capping and de-capping socket unit (123) capable of engaging and retaining a cap (113), having a through going passage (221),
- an ejector pin guide (220) also having a through going passage (221), and
- an ejector pin (230);

5
10
and wherein said socket unit (123) and said ejector pin guide (220) are so aligned that when said socket unit (123) is attached to said guide (220), said ejector pin (230) can perform a translational movement within the said guide (220) and said socket unit (123).

15
8. A capping and de-capping gripper (122) according to claim 7 wherein the said socket unit (123) is attachable and detachable to the said ejector pin guide (220).

20
9. A capping and de-capping gripper (122) according to either claim 7 or claim 8 further comprising

- an actuator unit (240) configured to induce a rotational movement in said ejector pin (230) upon actuation,
 - 25 - said actuator unit (240) comprising an actuator (250), preferably an electro motor, and optionally, a gear (260), and
 - said actuator unit (240) attached to said ejector pin (230), and

30

..... a means 231 for transferring a rotational movement of said ejector pin (230) to said ejector pin

guide (220) or to said capping and de-capping socket unit (123).

5 10. The capping and de-capping gripper of claim 9 further comprising a sensor configured to detect the torque on said actuator unit 240 and internal or external means for halting the rotational movement of said actuator unit 240 if a predetermined threshold value of torque acting on said actuator
10 unit 240 is exceeded.

11. A plurality of capping and de-capping grippers (123) according to any of the claims 7 to 10 so arranged within said capper and de-capper apparatus
15 (100) that each capping and de-capping gripper 123 is individually rotationally actuated and controlled.

12. A capping and de-capping socket unit (123)
20 capable of engaging and retaining a cap for use with a capping and de-capping gripper (122) according to any of the claims 7 to 11 comprising

- 25 - a gripper connector (310),
- a socket (320), and optionally
- a mechanical connection (330) between said gripper connector (310) and said socket (320);

30 each of said gripper connector (310), said socket (320), and said optional mechanical connection (330) having a through going passage (221)

characterized in that:

when the gripper connector (310), the socket (320), and the optional mechanical connection (330) are assembled to form said socket unit (123) the through going passages (221) are so aligned that when said capping and de-capping socket unit (123) is attached to said guide (220), said ejector pin (230) can perform a translational movement within the said guide (220) and said socket unit (123).

10 13. A capping and de-capping socket according to claim 12 further comprising a biasing means (223), preferably a coil spring, external to the said mechanical connection (330).

15 14. A capping and de-capping socket (320) for use in a capping and de-capping socket unit (132) according to any of the claims 12 or 13 comprising

- a through going passage (221), and
- 20 - at least one friction pin (321) oriented towards, away, or both towards and away, at right angles from the center line of said through going passage (221),

25 characterized in that

the said at least one friction pin (321) is oriented to either grab around a cap (113) or to be inserted into a cavity within said cap (113) or both to grab around and to be inserted into said cap (113).

30

15. A capping and de-capping socket (320) according to claim 14 further comprising an external spring

(340) encircling said capping and de-capping socket (320).

- 5 16. A capping and de-capping socket unit (123) or a capping and de-capping socket (320) according to any the claims 12 to 15 made from plastics, preferably PEEK or POM.
- 10 17. A capping and de-capping socket unit (123) or a capping and de-capping socket (320) according to claim 16 having been injection molded.
- 15 18. An apparatus (100) according to any of the claims 1 to 6 comprising at least one capping and de-capping gripper (122) according to any of the claims 7 to 11 and at least one capping and de-capping socket unit (123) according to any of the claims 12 to 17.
- 20 19. Use of an apparatus (100) according to any of the claims 1 to 6 or 18.
- 25 20. A method of operating an apparatus (100) according to any one of claim 1 to 6 or 18, to attach or detach at least on cap, said method comprising:
- moving the head unit 120 towards the rack support 110 by the drive system 130,
 - 30 - a capping and de-capping gripper 122 engages an opposing cap 113 on an opposing test tube 112 via the socket 320 on the socket unit 123, and
 - disengagement of the cap 113 from the test tube 112 is brought about by the concerted movement

of the drive system 130 moving the head unit 120 away from the rack support 110 and a simultaneous rotational movement of at least one gripper unit 122 caused by the at least one actuator unit 240 connected to said at least one capping and de-capping gripper 122 in contact with said cap 113, whereby

5
- caps in contact with a capping and de-capping gripper 122 but not undergoing a rotation by the actuator unit 240 forming part of such a capping and de-capping gripper 122 are not removed from their respective test tubes 112; and

10
- to attach a removed cap, the above steps are reversed and stopped when the means 270 for sensing the torque on the ejector pin registers that a certain threshold torque is exceeded; and

15
- to eject the tube 112 now having a cap by moving said tube 112 towards the ejector pin 230 by the drive mechanism 150, whereby the socket unit 123 and ejector pin guide 220 are moved past that end of the ejector pin 230 that is in contact with the cap 113 thereby releasing the said tube 112, freeing the capping and de-capping apparatus 100 to perform a new cycle of capping and de-capping.

20
25
30

ABSTRACT

TUBE CAPPING AND DE-CAPPING APPARATUS

5

An apparatus for automated capping and de-capping of test tubes having an ejector pin system for individualized cap ejection.

10

1/5

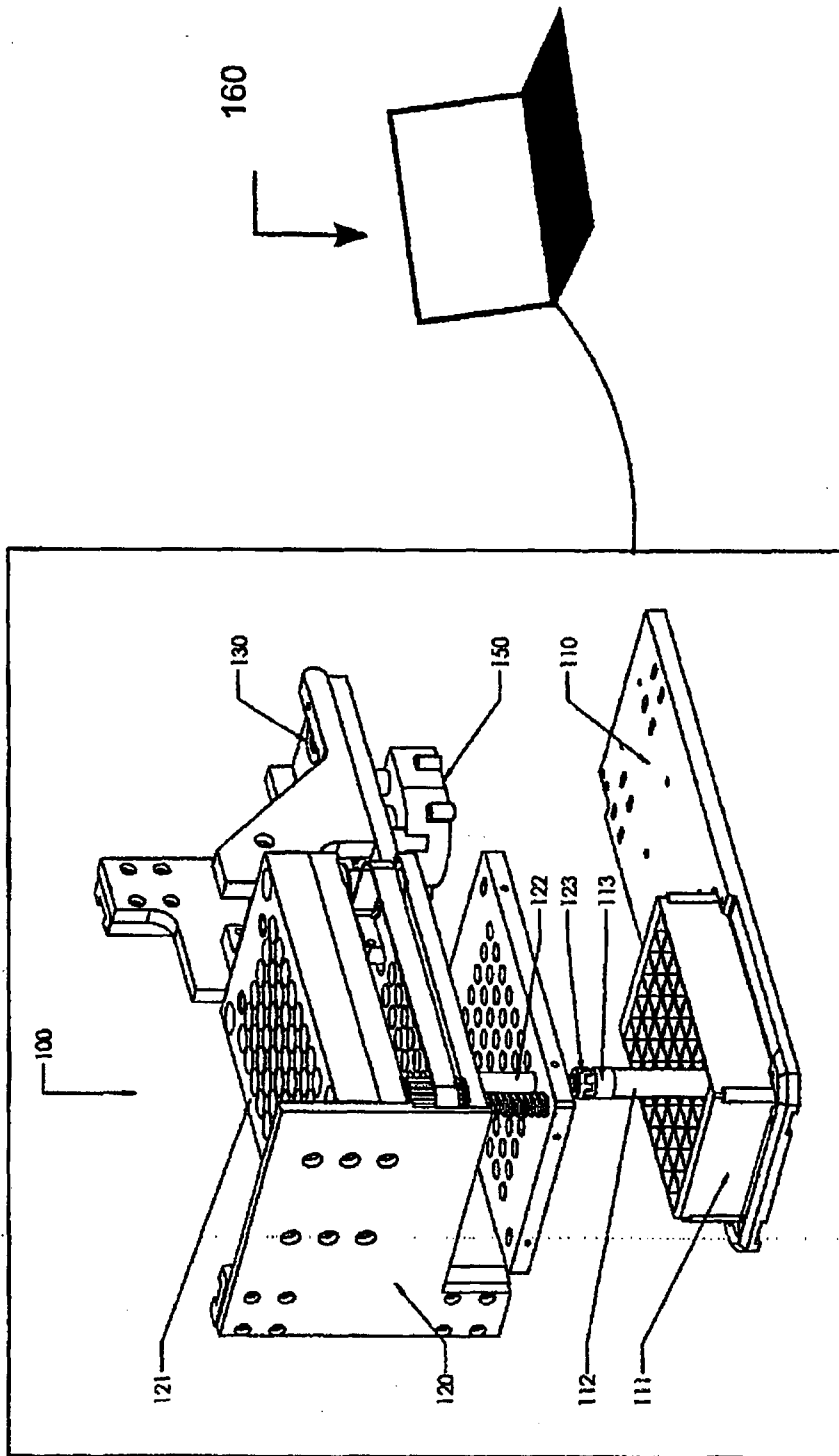

Figure 1a

2/5

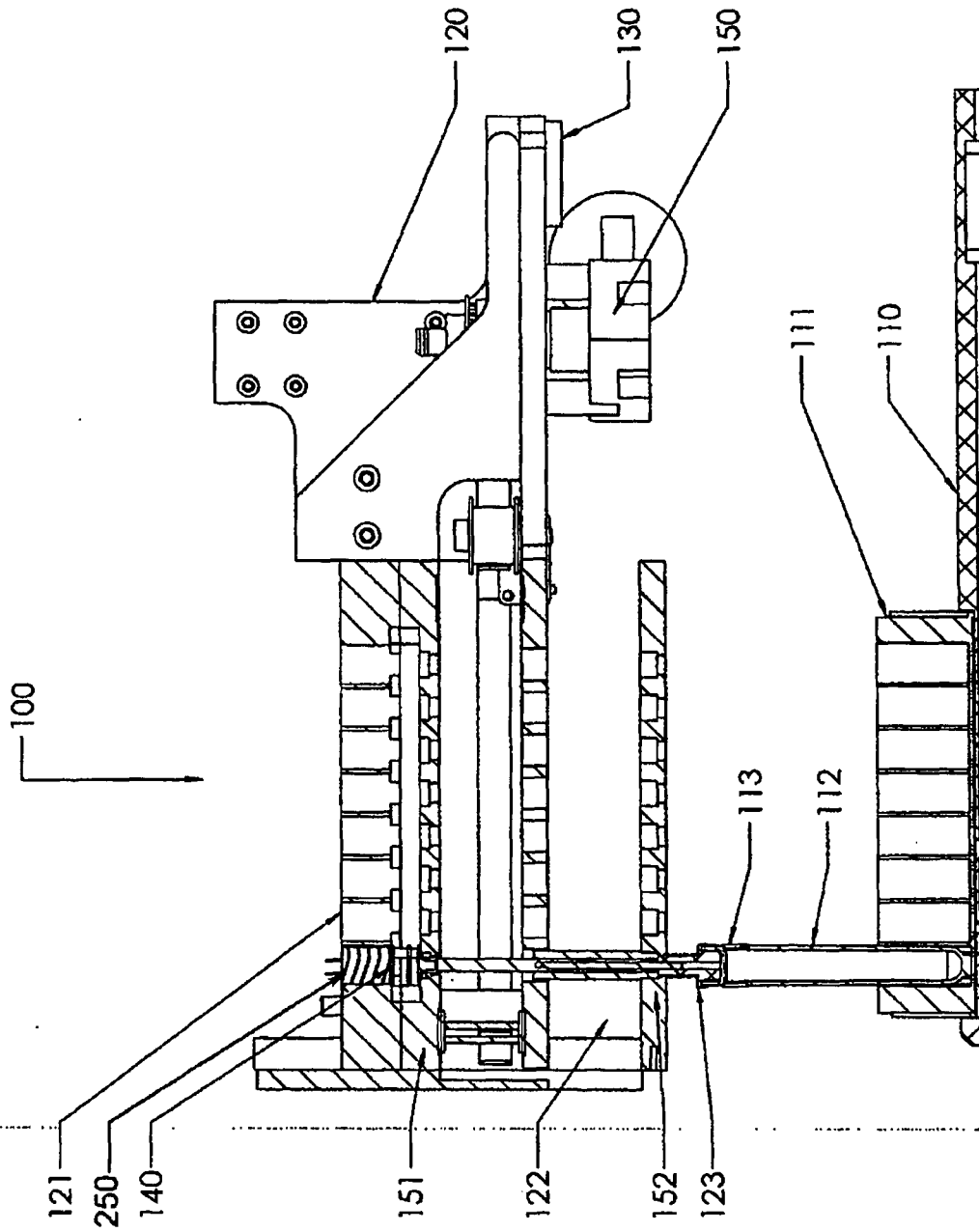

Figure 1b

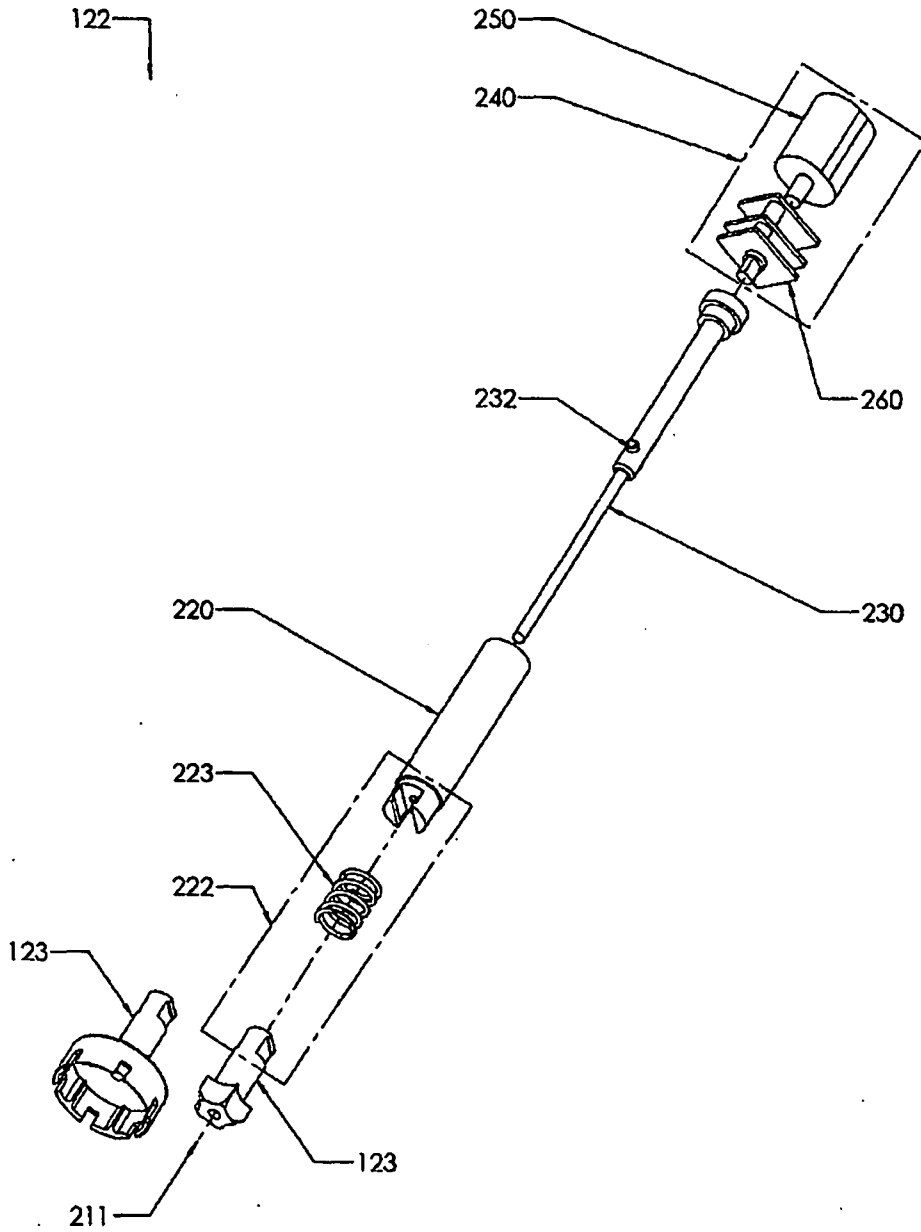

Figure 2

4/5

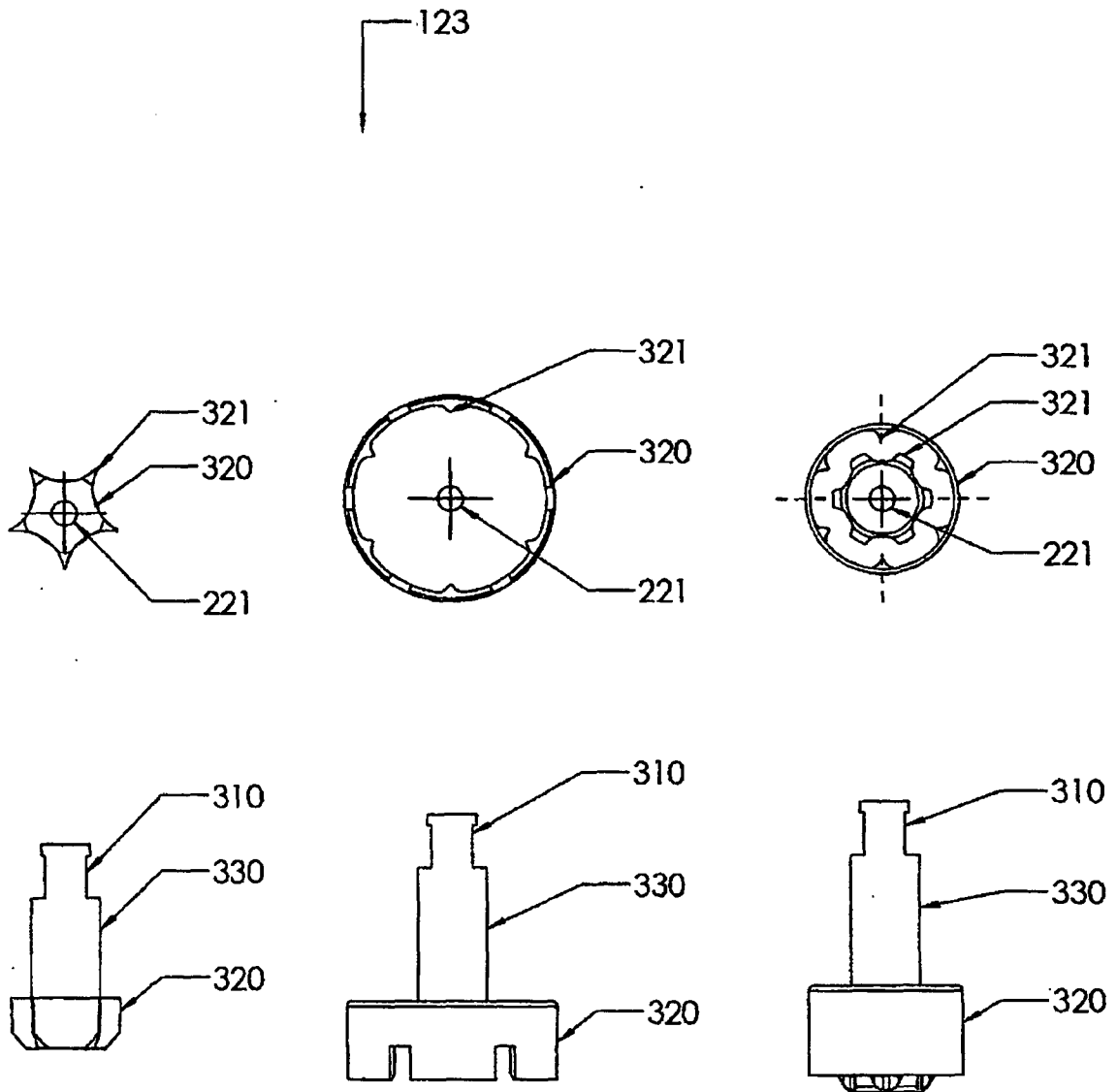

Figure 3a

5/5

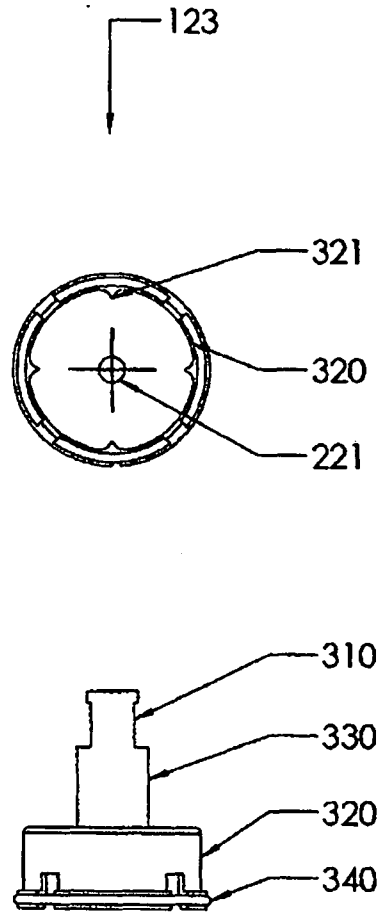

Figure 3b