

# **LED LIGHTING ASSEMBLY AND METHOD OF LIGHTING FOR A MERCHANDISE DISPLAY**

## **CROSS REFERENCE TO RELATED APPLICATIONS**

- [01] This Application is a continuation-in-part of U.S. Application Serial No. 13/162,076, filed June 17, 2011 which is a continuation-in-part of U.S. Application Serial No. 12/955,198, filed November 29, 2010. This application also claims priority to U.S. Provisional Application Serial No. 61/608,374, filed March 8, 2012.

## **FIELD OF INVENTION**

- [02] This invention relates generally to LED lighting assemblies for a merchandise display and methods of lighting. In particular, in one aspect of the invention, an LED light assembly is provided with a plurality of reflective surfaces located adjacent to the LEDs, wherein the reflective surfaces are positioned such that the LED projects a first light beam in a first direction and the reflective surface directs a second light beam in a second direction different than the first direction.

## **BACKGROUND**

- [03] In many retail stores it is desired to illuminate the front of product packages on merchandise display shelves to improve the product presentation, shopping environment, and to highlight products to ultimately improve the overall sales of the products.
- [04] Typically, this is accomplished with a fluorescent lighting fixture, which is located above a shelving unit and emits light down upon the front of the shelves. However, in most existing installations of this type, much of the light is not used because it is not captured and directed to the front of the shelves. Lack of focusing, specific reflectors, or beam modification results in product on higher shelves being too brightly illuminated and product on lower shelves receiving very little light at all.
- [05] Additionally, there are also significant costs with replacing lamps on fluorescent fixtures when they deteriorate or burn out including the costs of new lamps and labor to replace the lamps. In addition, when the lamps are replaced on the scale of a large

retail chain, replacement can become environmentally harmful since all fluorescent lamps contain mercury.

- [06] In one exemplary aspect of the present invention, more of the available light is directed to the front of products merchandised on a shelf and a higher illuminance per watt of power is output than with existing fluorescent fixtures. In another exemplary aspect of the present invention, a lower cost lighting solution is disclosed that uses less energy, directs and improves the illumination on the product packages, particularly on the lower shelves, and requires lower maintenance costs.

### SUMMARY

- [07] The following presents a general summary of aspects of the invention in order to provide a basic understanding of the invention and various features of it. This summary is not intended to limit the scope of the invention in any way, but it simply provides a general overview and context for the more detailed description that follows.
- [08] In one exemplary embodiment, a lighting assembly for a merchandise display is disclosed. The lighting assembly can comprise: (a) two opposing support arms and a lighting bar extending between the two opposing support arms, (b) a circuit board assembly having a plurality of LEDs mounted to the inside of the lighting bar, wherein the plurality of LEDs project a light in a beam pattern on a merchandise display; and (c) a plurality of reflective surfaces located adjacent to the LEDs, wherein the reflective surfaces are positioned such that the LED projects a first light beam in a first direction and the reflective surface directs a second light beam in a second direction different than the first direction. The lighting assembly may also include lenses placed over a corresponding one or more of the plurality of LEDs, and wherein the lenses capture the light from a respective LED, modify the beam pattern, and re-project the light.
- [09] In another exemplary embodiment, a lighting method for a merchandise display is disclosed. The method can comprise: (a) arranging a plurality of LEDs on a circuit board located within a lighting bar, wherein the plurality of LEDs project a light in a beam pattern on a merchandise display; (b) securing a plurality of reflective surfaces adjacent to the LEDs, wherein the reflective surfaces are positioned such that the LED

projects a first light beam in a first direction and the reflective surface directs a second light beam in a second direction different than the first direction. The lighting method may also include (c) securing a plurality of lenses to the circuit board; and (d) placing the plurality of lenses over one or more of the LEDs on the lighting bar so as to capture the light from a respective LED, modify a beam pattern emitted from the respective LED, and re-project the light emitted from the respective LED.

[10] Other objects and features of the invention will become apparent by reference to the following description and drawings.

### **BRIEF DESCRIPTION OF THE DRAWINGS**

[11] A more complete understanding of the present invention and certain advantages thereof may be acquired by referring to the following detailed description in consideration with the accompanying drawings, in which:

[12] Figure 1 shows a perspective view of exemplary lighting assemblies in use on a merchandise display;

[13] Figure 2 shows another perspective view of exemplary lighting assemblies;

[14] Figures 3A and 3B show top views of an exemplary circuit board assembly contained in the lighting assemblies;

[15] Figure 4 shows a perspective view of the exemplary circuit board assembly;

[16] Figure 5 shows a bottom perspective view of another exemplary lighting assembly;

[17] Figure 6 shows a top perspective view of the exemplary lighting assembly shown in Figure 5;

[18] Figure 7 shows a cross-section view of the exemplary lighting assembly from Figure 5;

[19] Figure 8 shows a bottom perspective view of another exemplary lighting assembly;

[20] Figures 9A through 9C show various beam angles for exemplary LEDs used in accordance with this disclosure;

- [21] Figures 10A and 10B show cross-section views of embodiments of the exemplary lighting assembly from Figure 8;
- [22] Figure 11A and 11B show cross-section views of other embodiments of the exemplary lighting assembly from Figure 8; and
- [23] Figure 12 shows a cross-section view of another embodiment of the exemplary lighting assembly from Figure 8.
- [24] The reader is advised that the attached drawings are not necessarily drawn to scale.

### **DETAILED DESCRIPTION**

- [25] In the following description of various example structures in accordance with the invention, reference is made to the accompanying drawings, which form a part hereof, and in which are shown by way of illustration of various structures in accordance with the invention. Additionally, it is to be understood that other specific arrangements of parts and structures may be utilized, and structural and functional modifications may be made without departing from the scope of the present invention. Also, while the terms “top” and “bottom” and the like may be used in this specification to describe various example features and elements of the invention, these terms are used herein as a matter of convenience, *e.g.*, based on the example orientations shown in the Figures and/or the orientations in typical use. Nothing in this specification should be construed as requiring a specific three dimensional or spatial orientation of structures in order to fall within the scope of this invention.
- [26] Figures 1 and 2 depict exemplary LED lighting assemblies 10 for a merchandise display. As shown in Figures 1 and 2, the LED lighting assemblies 10 each include a housing 12, a circuit board assembly 24, and a circuit board 16 having an LED driver circuit 22 (shown in Figure 3B). The housing 12 can include a series of clamps 28 for securing the housings above the area being illuminated. A plurality of LED emitters 20 are mounted to the circuit board 16 and are powered with the LED driver circuit 22. As shown in Figure 4, the LEDs are spaced apart from each other along the circuit board assembly 24. The circuit board assembly 24 is also connected to a power cord 18.

- [27] The lenses 14 can be secured over individual LED emitters 20 to provide different refractive properties for reflecting the light emitted by the LEDs in various angles and directions such as over product shelves. As shown in Figures 3A and 3B, the lenses 14 can be provided with different refractive configurations. However, alternatively, the lenses can all be provided with the same refractive configurations. In another alternative embodiment, the lenses may be placed over every other LED to modify the light pattern. Other arrangements are also contemplated to provide optimal lighting properties and configurations depending on the environment and desired results.
- [28] The lenses 14 may be secured to the circuit board assembly 24 via a snap fit or by any other known suitable connection. The lenses may be fixed individually, for example, one lens per one LED or one or more lenses may be connected together to create a uniform, one-piece lens assembly that is easier, faster, and more cost effective to install on the circuit board assembly.
- [29] The LED lighting housing can be adjustable in several ways to adjust the orientation of the housing and to fine tune the position of the projected light. First, the housing can be adjusted on horizontal arms (not shown) that are generally perpendicular to the long edge of the shelves and positioned above the top shelf in a set of shelves. This adjustment allows the LED lighting assembly to be moved closer to or farther from the plane being illuminated. The second adjustment allows the assembly to rotate about its horizontal axis 26 to direct light at a different angle in the plane. The two adjustments change the angle at which the light intercepts the product faces. Moving the lighting fixture away from the product on the horizontal arms can improve the lighting on the lower positioned product by reducing shadows on the product caused by the lower shelves.
- [30] Each of the LED lighting assemblies 10 modify the light output from the point source LED emitters 20 to illuminate an artificial planar surface area which can be represented by a front surface of product on a shelf in a retail store. Each LED lighting assembly can be approximately the length of a shelf in a retail store, typically 3ft or 4ft long, or even as short as 6 inches or as long as 20 feet. The LED lighting assemblies 10 can be positioned in a horizontal orientation above a product on the top shelf and slightly in front of an artificial plane. The LED lighting assembly 10 may also be positioned in any other location with respect to the product, not necessarily

only in alignment with the shelf. The light is modified by the plurality of lenses 14 fitted onto the circuit board 16 and over the LEDs 20 to capture the light from an LED, modify the beam pattern, and re-project the light evenly over a vertical plane in front of the product shelves.

- [31] In another exemplary embodiment, as illustrated in Figures 5 through 7, another lighting assembly 110 is depicted. The lighting assembly 110 (or illumination device) may include two opposing support arms 111 and a lighting bar 112 extending between the two support arms 111. The two support arms 111 may be mountable into the support posts of a gondola type merchandise display shelf. Typically, the support arms 111 and the lighting bar 112 are positioned above the top shelf of the merchandise display system. The support arms 111 and the lighting bar 112, however, can be located at any desired position on the merchandise display system.
- [32] The lighting bar 112 may define a C-shaped configuration in cross-section. The lighting bar 112 may define other shapes and other sized configuration in cross-section without departing from this disclosure. The lighting bar 112 may act as a housing to a plurality of light emitting diodes (LED) 120 and may be configured to mount these LEDs 120 on the inside of the C-shaped cross section, as illustrated in Figures 5 and 7. The lighting bar 112 may be made of metal or any other suitable material. The LEDs 120 may be spaced along the lighting bar 112 on the inside of the lighting bar 112 as shown in Figures 5 and 7. The LEDs 120 may be electrically coupled together by a circuit board 116 positioned on the lighting bar 112. The circuit board 116 may also incorporate the appropriate resistors to control the power supplied to each LED 120.
- [33] The LEDs 120 may provide any desired color, which may be controlled by the semiconductor material of the LED light 120. As illustrated in Figures 5 and 7, a reflector or lens 114 may be positioned around every other LED 120 on the lighting bar 112. The reflectors or lens 114 may also be placed intermittently around LEDs 120 on the lighting bar 112. The reflector or lens 114 may also be positioned in irregular patterns around LEDs 120 on the lighting bar 112. The reflector or lens 114 serves the purpose of directing the emitted light in a desired direction and angle. The reflector or lens 114 may be positioned and oriented at any of the numerous possible angles to direct light in the desired direction. With the use of the alternating

arrangement of LEDs 120 with reflectors 114 and without reflectors 114, it has been determined that the light emitted from the lighting bar 112 covers the entire merchandise display system, from the top shelf to the bottom shelf. As a result, all shelves of the merchandise display system are properly illuminated which makes the products on those shelves more visible and attractive to consumers. Additionally, the lens systems 14 as described in the first embodiment and illustrated in Figures 1 through 4 may be utilized with this lighting assembly.

- [34] It should be understood that other lighting configurations are possible with the lighting bar 112 to adequately direct light to the entire merchandise display system. For example, it is possible to position reflectors over every third or fourth LED 120, and so on. Also, it is possible for the lighting bar 112 to define other numerous shapes and configurations, depending on the type of shelf and merchandise display system on which the lighting bar 112 is used.
- [35] In another exemplary embodiment, as illustrated in Figures 8 through 12, another lighting assembly 210 is depicted. The lighting assembly 210 (or illumination device) may include two opposing support arms 211 and a lighting bar 212 extending between the two support arms 211. The two support arms 211 may be mountable into the support posts of a gondola type merchandise display shelf or any other similar display shelf. Typically, the support arms 211 and the lighting bar 212 are positioned above the top shelf of the merchandise display system. The support arms 211 and the lighting bar 212, however, can be located at any desired position on the merchandise display system.
- [36] Generally, the lighting bar 212 may define a C-shaped configuration in cross-section. The lighting bar 212 may act as a housing to a plurality of light emitting diodes (LED) 220 and may be configured to mount these LEDs 220 on the inside of the C-shaped cross section, as illustrated in Figures 5 and 7. The lighting bar 212 may be made of metal or any other suitable material. The LEDs 220 may be spaced along the lighting bar 212 on the inside of the lighting bar 212 as shown in Figures 5 and 7. The LEDs 220 may be electrically coupled together by a circuit board 216 positioned on the lighting bar 212.

- [37] Generally, LEDs 220 output a directional beam 222. The LED 220 may also include a given beam angle 224 that is output from the LED 220. As illustrated in Figures 9A-9C, LEDs 220 may have beam angles 224 of approximately 80 degrees, 120 degrees, or 180 degrees. LEDs with other beam angles 224 may be utilized or incorporated with the lighting system. Figure 9A illustrates a beam angle 224 of approximately 80 degrees. Figure 9B illustrates a beam angle 224 of approximately 120 degrees. Figure 9C illustrates a beam angle 224 of approximately 180 degrees.
- [38] A reflective surface 230 may be positioned near or adjacent the output of one or more of the LEDs 220. The reflective surface 230 may allow better control of a portion of the beam. The reflective surface 230 may also allow the deflection/reflection of a portion of the beam 222. Additionally, as will be explained in detail below, the reflective surface 230 may also allow the splitting or dividing of the beam 222 to thereby create multiple beams 222 projecting from the LED. As illustrated in Figures 10A and 10B, the reflective surface is positioned adjacent to the LED 220 and the projected beam 222 of the LED 220. As illustrated in Figures 10A and 10B, the reflective surface may direct a portion of the projected beam 222 from the LED 220 in a different direction, thereby creating two different beams of light 222A and 222B.
- [39] In one embodiment, the reflective surface 230 may be positioned parallel to the path of the beam 222, but only covering and/or reflecting a portion of the beam 222. For example, as shown in Figure 11A, the reflective surface 230 is positioned parallel to the path of the beam 222, but only covering and/or reflecting approximately half of the beam 222. The reflective surface 230 thereby allows approximately 50% of the beam 222 to project in the direction that the LED 220 is directionally pointing (downward in this illustration), while reflecting the other 50% of the beam 222 in a direction based on the position and angle of the reflective surface 230 (horizontal in this illustration). This use of the reflective surface 230 with one LED 220 thereby can create two different LED beams 222 using just one LED 220. Figure 10A illustrates a first beam 222A projecting in a downward or vertical direction, wherein the first beam 222A is not reflected from the reflective surface 230. Figure 10A also illustrates a second beam 222B projecting in a linear or horizontal direction, wherein the second beam 222B is reflected by the reflective surface 230. Furthermore, as illustrated in Figure 12, the LED 220 with the reflective surface 230 may create a first beam 222A



that projects as a down light and a second beam 222B that projects as a back light against product shelving.

- [40] Without departing from this disclosure, the amount that the reflective surface reflects can be varied. In one exemplary embodiment, as illustrated in Figure 11B, the reflective surface may allow approximately 30% of the beam to project in the direction that the LED is directionally pointing (downward in this illustration), while reflecting the other 70% of the beam in a direction based on the position and angle of the reflective surface (horizontal in this illustration). In another exemplary embodiment, the reflective surface may allow approximately 70% of the beam to project in the direction that the LED is directionally pointing, while reflecting the other 30% of the beam in a direction based on the position and angle of the reflective surface. The reflective surface may allow a minimal percent (just more than 0%) of the beam to 99% of the beam to project in the direction that the LED is directionally pointing, while reflecting the remaining portion of the beam.
- [41] Generally, the reflective surface 230 may be a mirror. The reflective surface 230 may be other surfaces without departing from this invention, such as white/shiny, textured, or an optical film with surface coatings. Other reflective surfaces 230 not contemplated at this time may also be utilized without departing from this disclosure. The reflective surface 230 may be a flat reflective surface, or a flat mirror. In another embodiment without departing from this disclosure, the reflective surface 230 may be a curved reflective surface, or a curved mirror. Other surface geometry may be utilized for the reflective surface 230 without departing from this disclosure. Figure 10A illustrates a curved reflective surface 232. Figure 10B illustrates a flat reflective surface 234. Additionally, the reflective surface 230 may be an intermittent mirror or a continuous mirror without departing from this disclosure.
- [42] For a series of LEDs 220 on a lighting bar 212, the reflective surfaces 230 may be utilized at different and specified intervals throughout the series of LEDs 220. In one embodiment, one individual reflective surface 230 may be utilized for each of the LEDs 220 on the lighting bar 212. In another embodiment, one continuous reflective surface 230 may be utilized for all of the LEDs 220 on the lighting bar 212. In another embodiment and as illustrated in Figure 8, one individual reflective surface 230 may be utilized on intermittent LEDs 220 on the lighting bar 212 at specified

intervals throughout the series of LEDs. For example, if there are ten LEDs 220 on the lighting bar 212, there may be five reflective surfaces 230 utilized with five of the ten individual LEDs 220 on the lighting bar 212. Other combinations may be utilized without departing from this disclosure, such as ten LEDs 220 on the lighting bar 212 with three of the ten individual LEDs 220 covered with a reflective surface 230 or ten LEDs 220 on the lighting bar 212 with seven of the ten individual LEDs 220 covered with a reflective surface 230.

- [43] In conjunction with reflective surfaces 230, the LEDs 220 may also include a reflector or lens 214 positioned around one or more of the plurality of LEDs 220 on the lighting bar 212. The reflector or lens 214 may serve the purpose of focusing and/or directing the emitted light in a desired direction and angle, and then projected onto the reflective surfaces 230. The reflector or lens 214 may be positioned and oriented at any of the numerous possible angles to direct light in the desired direction.
- [44] It should be understood that other lighting configurations and combinations are possible with the lighting bar 212 to adequately direct light to the entire merchandise display system. For example, it is possible to vary and/or combine different configurations of reflectors and reflective surfaces over various LEDs 220 on the lighting bar 212. Also, it is possible for the lighting bar 212 to define other numerous shapes and configurations, depending on the type of shelf and merchandise display system on which the lighting bar 212 is used.
- [45] The modified light projected onto the products on the retail shelf is relatively consistent in brightness over the planar surface and adds sufficient relative brightness beyond the general store luminaire lighting to call attention to or highlight the product merchandised on the shelf. Also, utilizing the reflective surfaces and the lensing technique directs the available LED light such that the lighting pattern produced on the planar surface and the product faces is far more homogenous than that of a fluorescent system. Top, center, and lower product on the shelves is relatively evenly illuminated providing the desired effect for the consumer shopper. The modified light projected onto the products may increase shopper awareness of the products, better present the products, and increase the sales of products.

- [46] By capturing and directing a higher percentage of total light output from the LEDs using appropriate lensing and/or reflective surfaces, the illuminance per watt can be higher than is generally possible with a fluorescent light, adding to a further reduction in necessary power input to achieve the desired lighting effect and energy savings. Additionally, by reflecting a portion of the total light output from the LED using appropriate reflective surfaces, the light beams can be more efficiently utilized, thereby adding to an even further reduction in the necessary power input to achieve the desired lighting effect and energy savings.
- [47] The LED circuit board and housing is designed to be thermally efficient and to remove as much heat from the LED as possible. Projected life of the LEDs is on the order of 4-6 times than that of typical existing fluorescent lamps. This reduces service call frequency by four to five times and commensurate cost.
- [48] Cost savings from reduced energy use and fewer service calls, along with improved sales from better product presentation may offset the cost of replacing existing fluorescent fixtures with an LED lighting fixture.
- [49] The reader should understand that these specific examples are set forth merely to illustrate examples of the invention, and they should not be construed as limiting the invention. Many variations in the lighting assemblies may be made from the specific structures described above without departing from this invention.
- [50] While the invention has been described in detail in terms of specific examples including presently preferred modes of carrying out the invention, those skilled in the art will appreciate that there are numerous variations and permutations of the above described systems and methods. Thus, the spirit and scope of the invention should be construed broadly as set forth in the appended claims.

## CLAIMS

We Claim:

1. A lighting assembly for a merchandise display comprising:

two opposing support arms and a lighting bar extending between the two opposing support arms, wherein the lighting bar is defined by a C-shaped configuration in cross section;

a circuit board assembly having a plurality of LEDs mounted to the inside of the lighting bar, wherein the plurality of LEDs project a light onto a merchandise display; and

a plurality of reflective surfaces located adjacent to the plurality of LEDs, wherein the plurality of reflective surfaces are positioned such that the LEDs project a first light beam in a first direction and the plurality of reflective surfaces direct a second light beam in a second direction different than the first direction.

2. The lighting assembly of claim 1, wherein the lighting bar adjusts the orientation of the circuit board assembly.

3. The lighting assembly of claim 1, wherein the plurality of reflective surfaces each individually fit over one of the plurality of LEDs to distribute the light emitted from the plurality of LEDs in a substantially even distribution in the first direction and the second direction.

4. The lighting assembly of claim 1, wherein the first light beam projects in a vertical direction and the second light beam projects in a horizontal direction.

5. The lighting assembly of claim 1, wherein the first light beam projects approximately 30% of the light in a vertical direction and the second light beam projects approximately 70% of the light in a horizontal direction.

6. The lighting assembly of claim 1, wherein the plurality of reflective surfaces are flat mirrors.

7. The lighting assembly of claim 1, wherein the plurality of reflective surfaces are curved mirrors.

8. A merchandise display lighting method comprising:

arranging a plurality of LEDs on a circuit board located within a lighting bar that defines a C-shaped configuration in cross section, wherein the plurality of LEDs project a light onto a merchandise display;

securing a plurality of reflective surfaces to the circuit board; and

placing the plurality of reflective surfaces adjacent to the plurality of LEDs, wherein the plurality of reflective surfaces are positioned such that the LEDs project a first light beam in a first direction and the plurality of reflective surfaces direct a second light beam in a second direction different than the first direction.

9. The lighting method of claim 8 further comprising adjusting the beams with the lighting bar.

10. The lighting method of claim 8, wherein the first light beam projects in a vertical direction and the second light beam projects in a horizontal direction.

11. The lighting method of claim 8, wherein the plurality of reflective surfaces are flat mirrors.

12. The lighting method of claim 8, wherein the plurality of reflective surfaces are curved mirrors.

13. An LED lighting system for a merchandise display comprising:

a lighting bar;

a circuit board assembly having a plurality of LEDs mounted to the inside of the lighting bar, wherein the plurality of LEDs project a light beam onto a merchandise display; and

one or more reflective surfaces positioned parallel to the path of the light beam from the LEDs and covering a portion of the light beam, wherein the plurality of LEDs project a first beam in a first direction and the one or more reflective surfaces direct a second beam in a

second direction different than the first direction, wherein the first direction is based on a direction the LED is directionally pointing and the second direction is based on a position and an angle of the one or more reflective surfaces covering the light beam.

14. The LED lighting system of claim 13, wherein the first beam projects in a vertical direction and the second beam projects in a horizontal direction.

15. The LED lighting system of claim 13, wherein one individual reflective surface covers each individual LED on the lighting bar.

16. The LED lighting system of claim 13, wherein one continuous reflective surface covers all of the plurality of LEDs on the lighting bar. 17. The LED lighting system of claim 13, wherein one individual reflective surface covers intermittent LEDs on the lighting bar in an alternating pattern.

17. The LED lighting system of claim 13 further including a plurality of lenses placed over a corresponding one of the plurality of LEDs such that the plurality of lenses focus and direct the light beam in a desired direction and angle and projected onto the one or more reflective surfaces.

18. The LED lighting system of claim 13, wherein the first beam projects approximately 30% of the light beam in a vertical direction and the second beam projects approximately 70% of the light beam in a horizontal direction.

19. The LED lighting system of claim 13, wherein the plurality of reflective surfaces are flat mirrors.

20. The LED lighting system of claim 13, wherein the plurality of reflective surfaces are curved mirrors.

# **LED LIGHTING ASSEMBLY AND METHOD OF LIGHTING FOR A MERCHANDISE DISPLAY**

## **ABSTRACT OF THE DISCLOSURE**

Aspects of the disclosure relate to a lighting assembly and method for illuminating a vertical planar area, such as a merchandise display. The lighting assembly can comprise two opposing support arms and a lighting bar extending between the two opposing support arms, a circuit board having a plurality of LEDs mounted to the inside of the lighting bar; and a plurality of reflective surfaces located adjacent to the plurality of LEDs, wherein the plurality of reflective surfaces are positioned such that the LEDs project a first light beam in a first direction and a second light beam in a second direction different than the first direction.

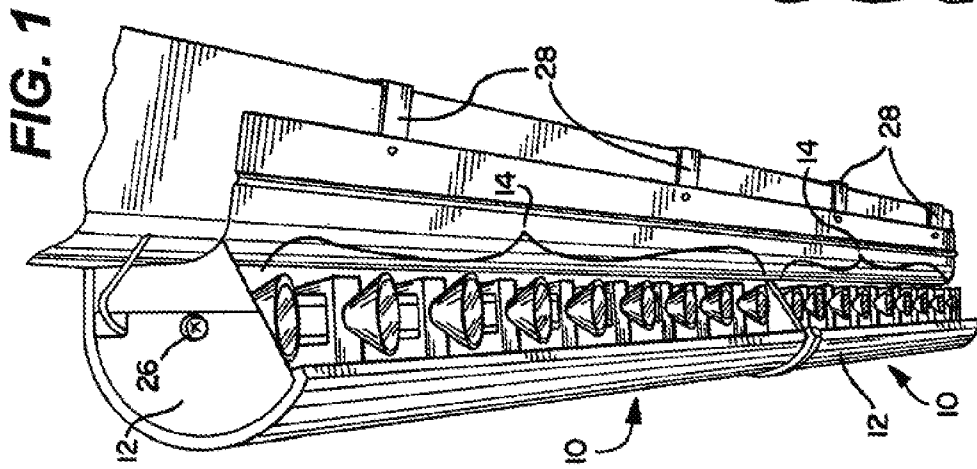
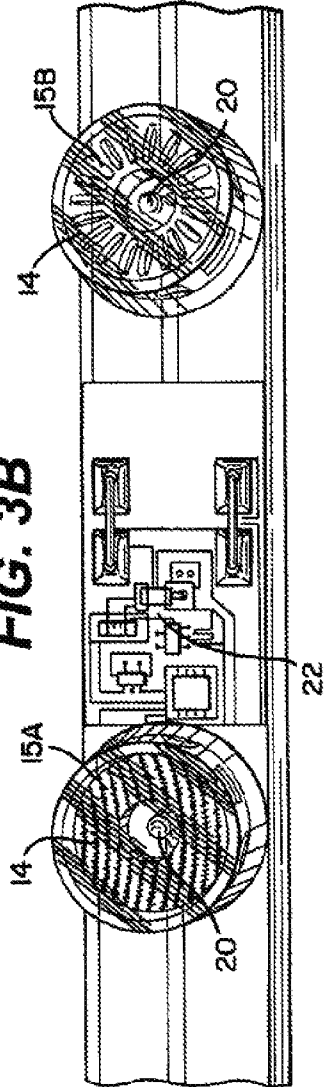


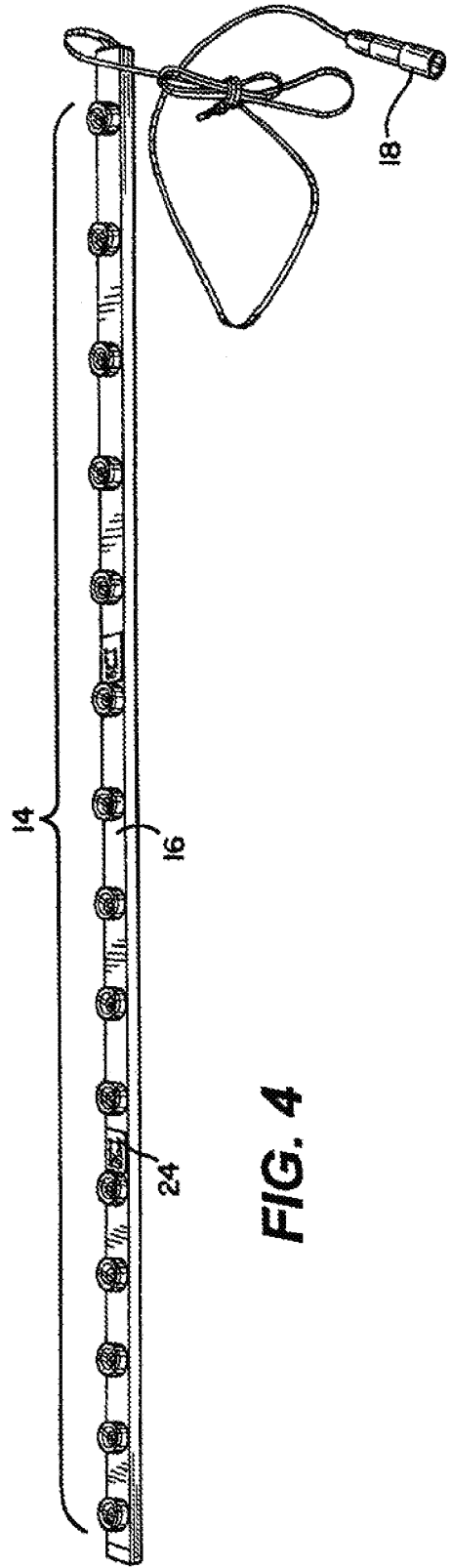
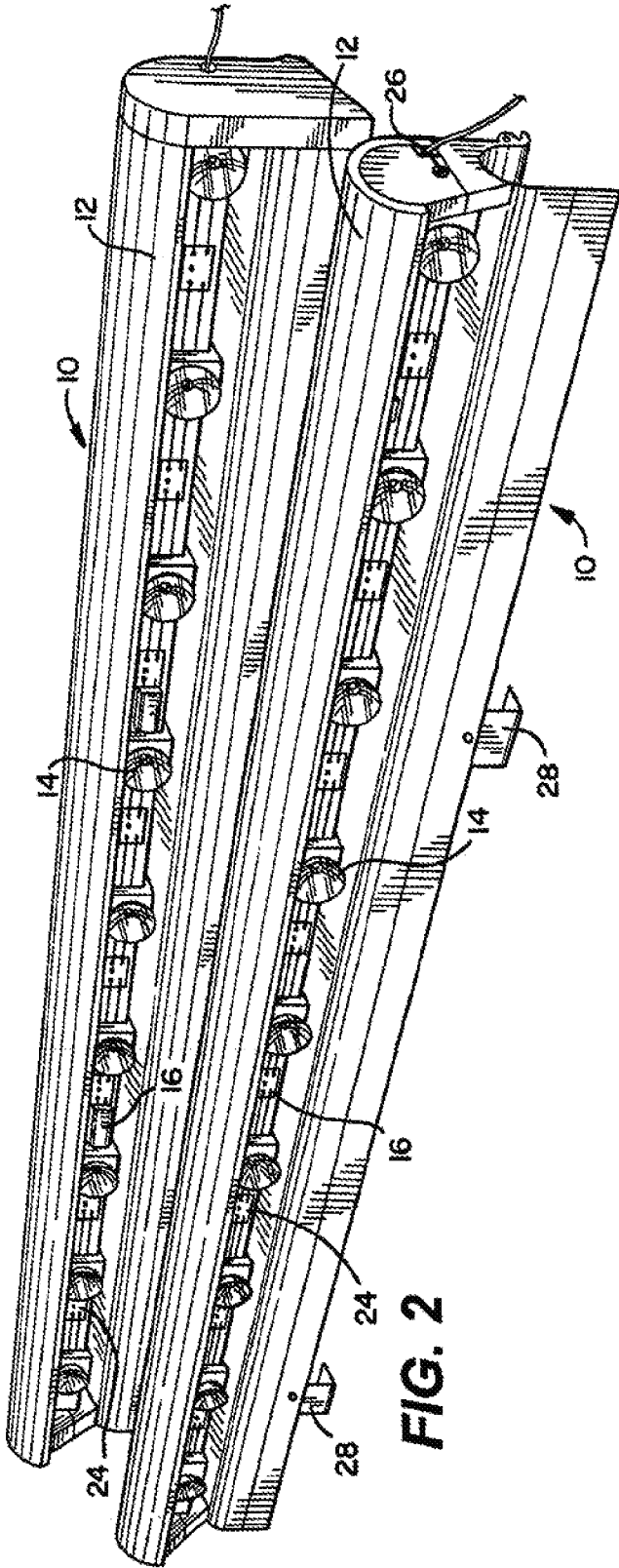
FIG. 3A

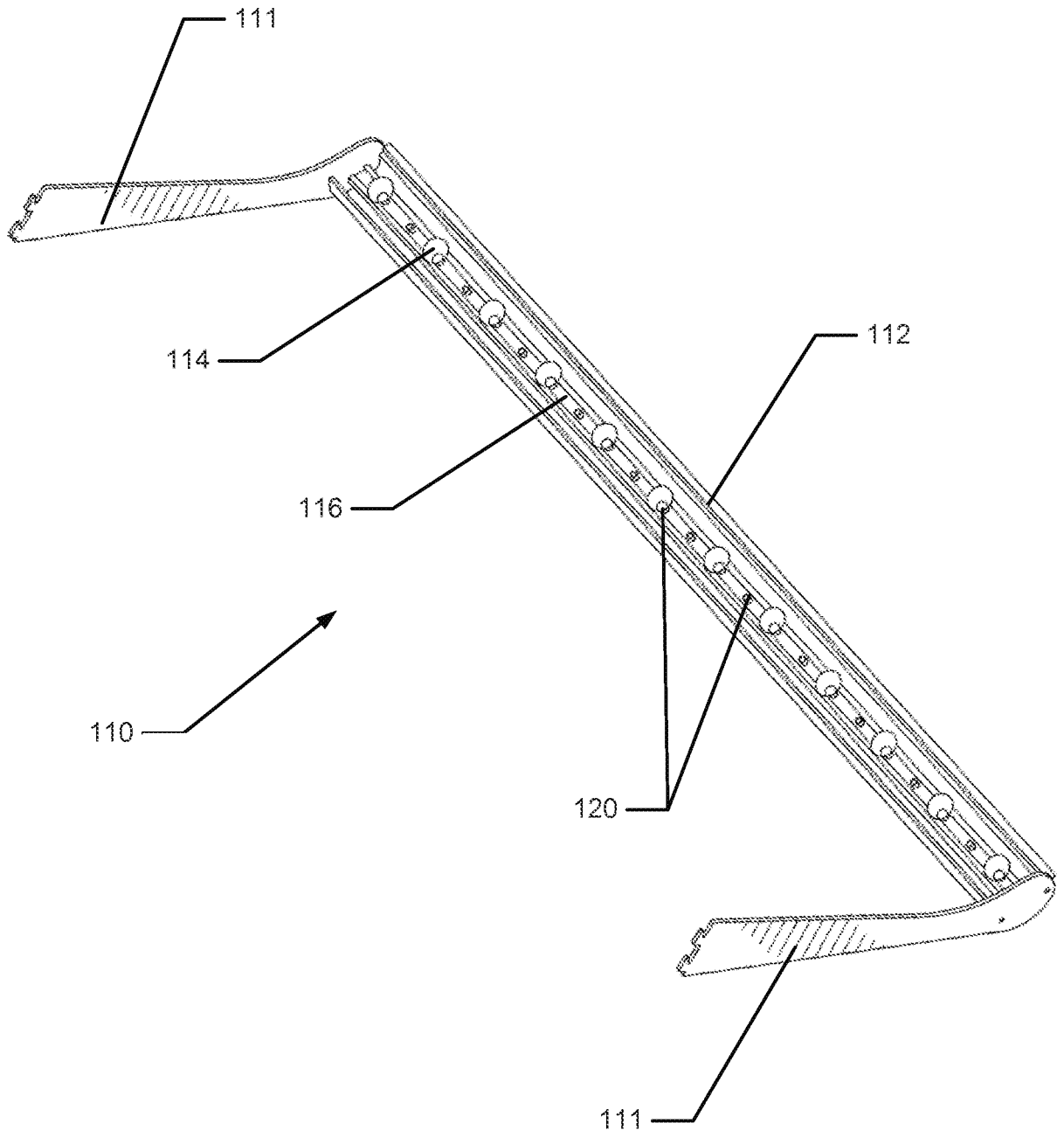


FIG. 3B

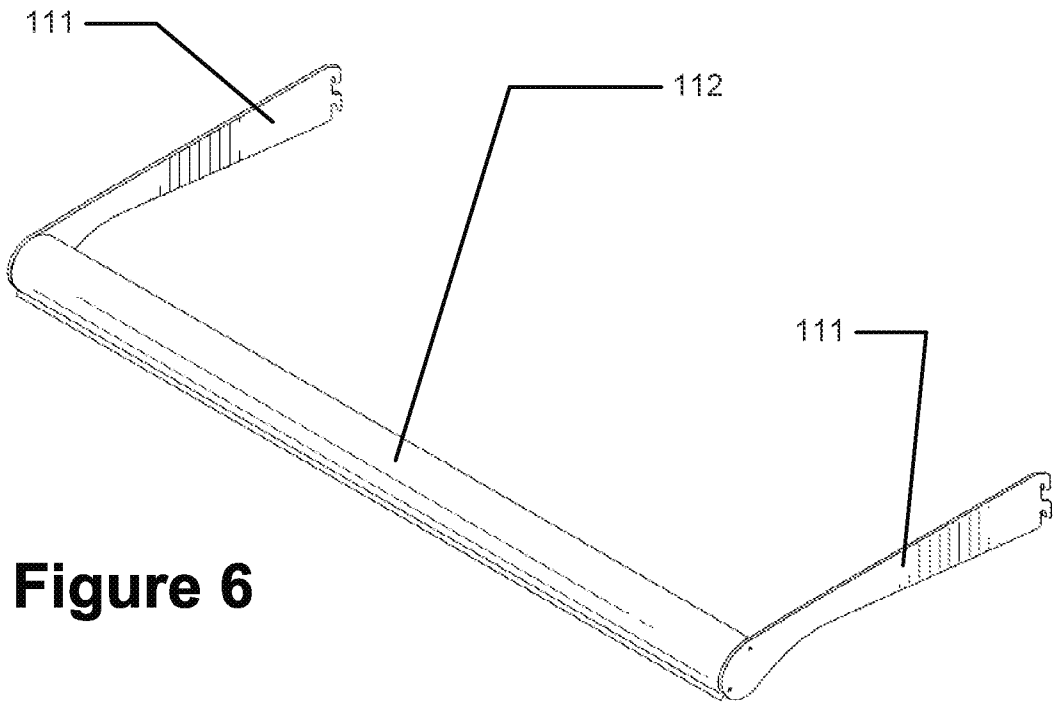




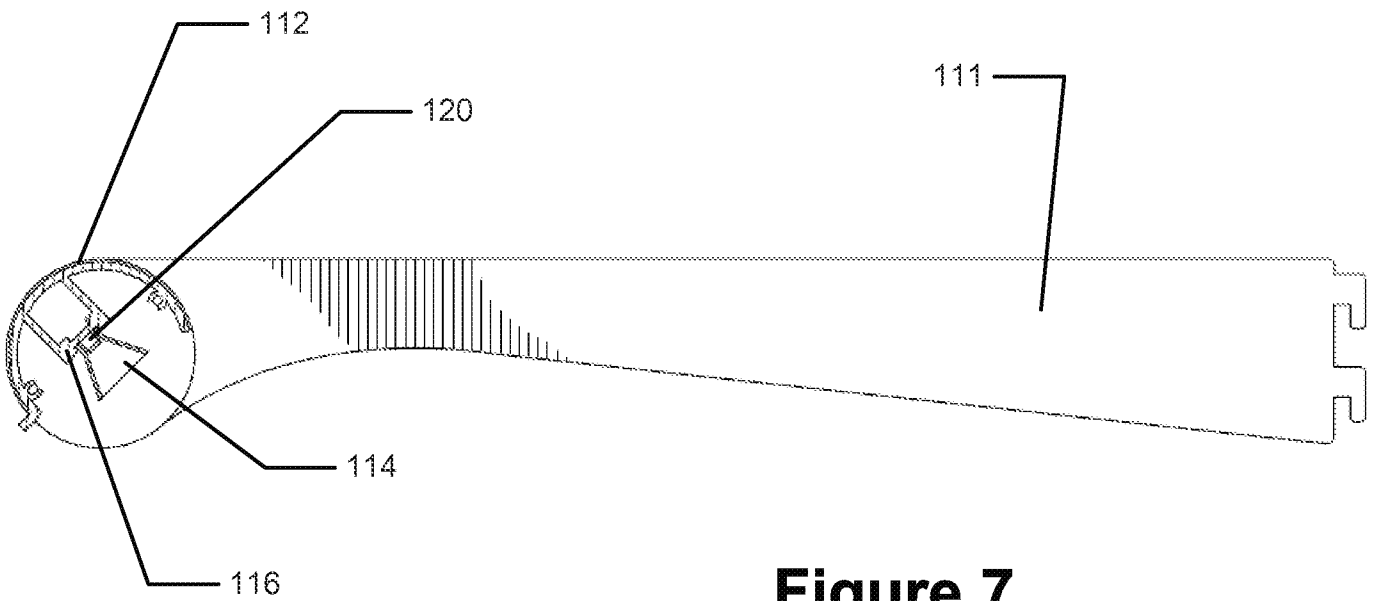




**Figure 5**



**Figure 6**



**Figure 7**

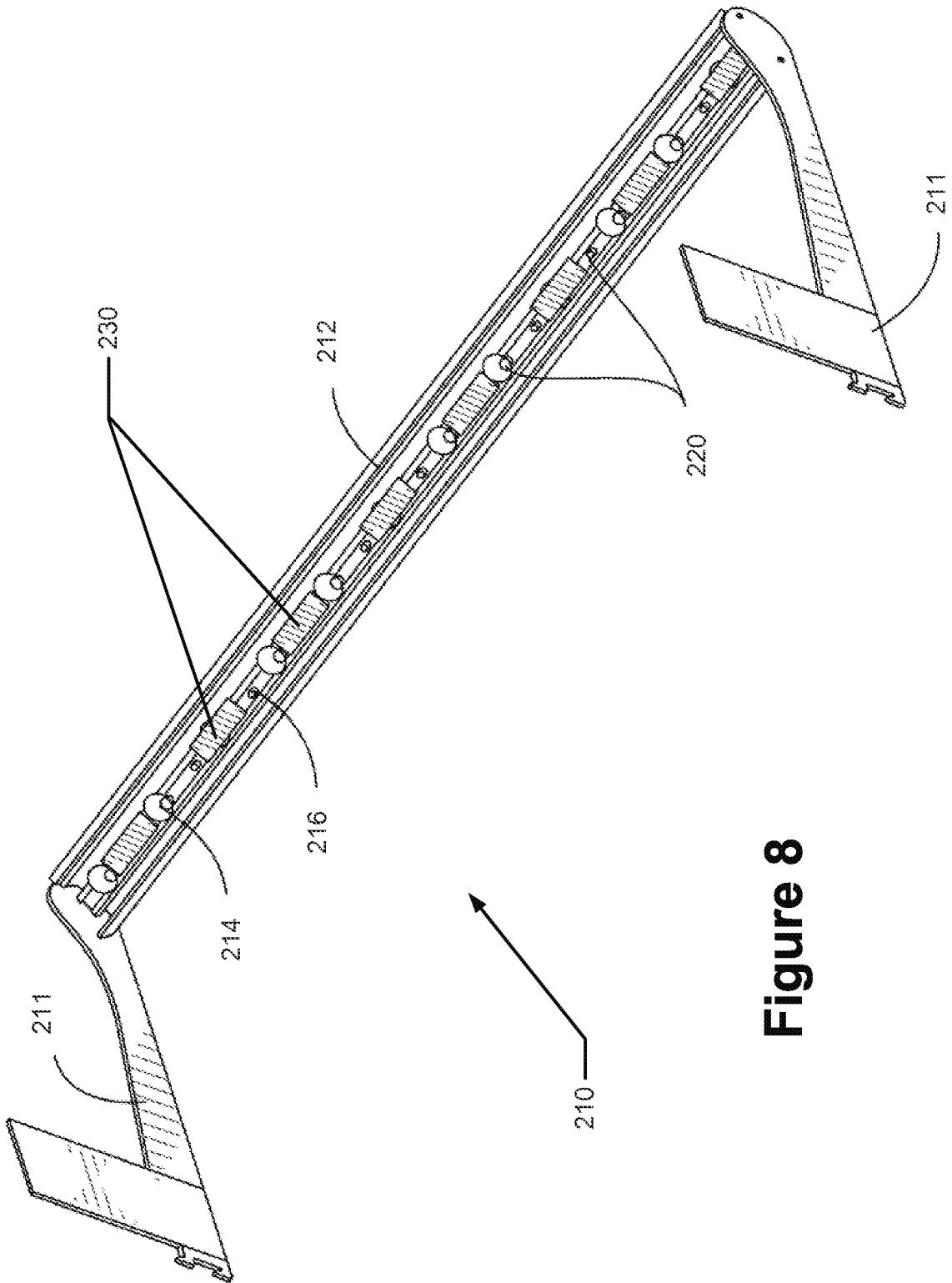
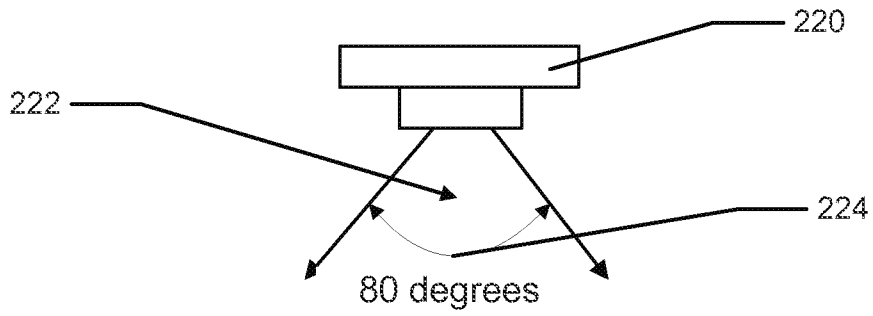
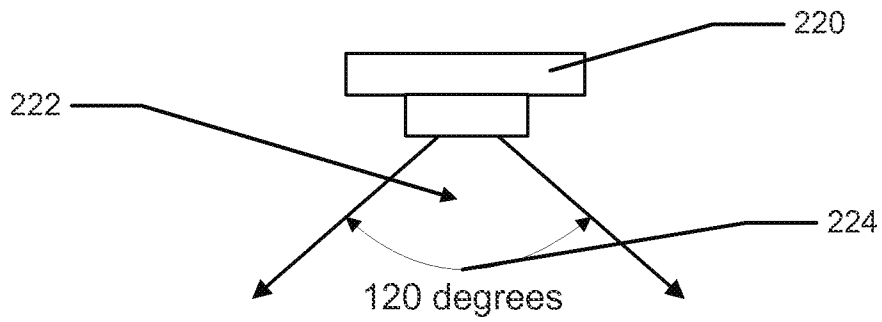


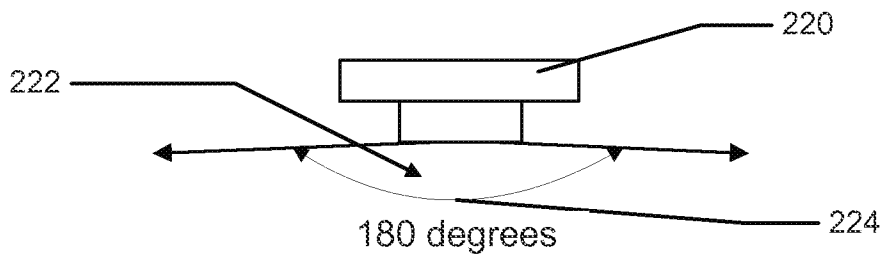
Figure 8



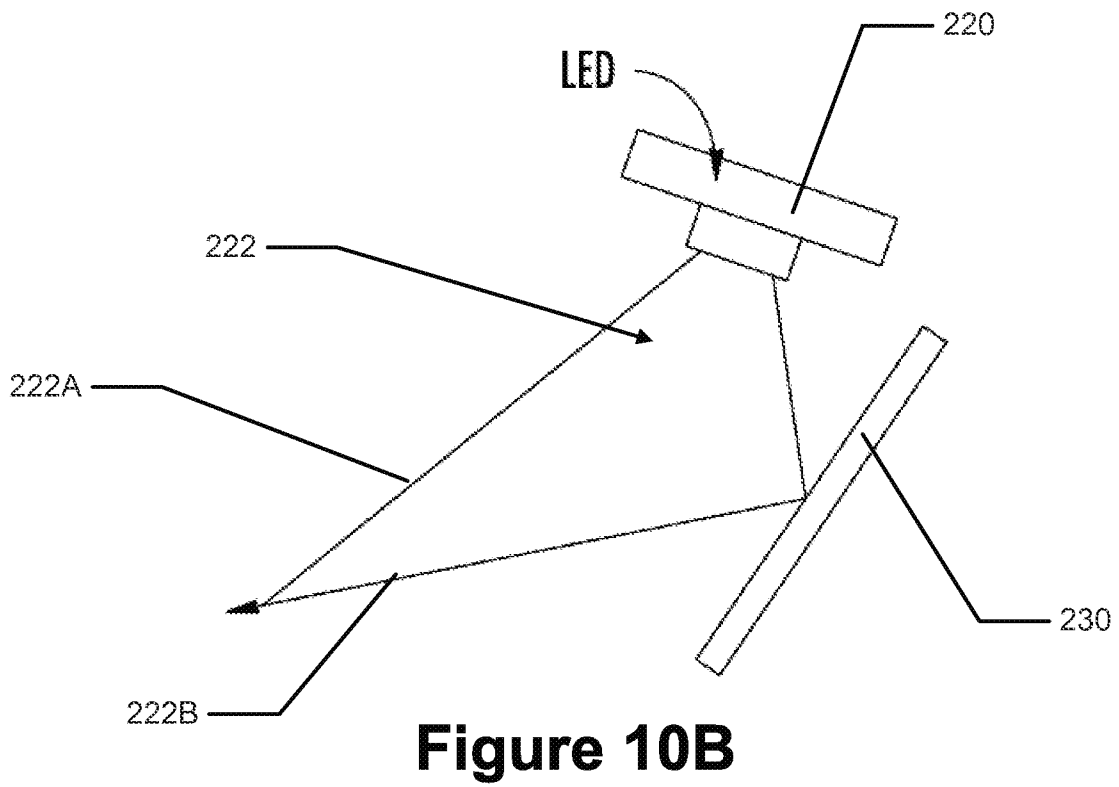
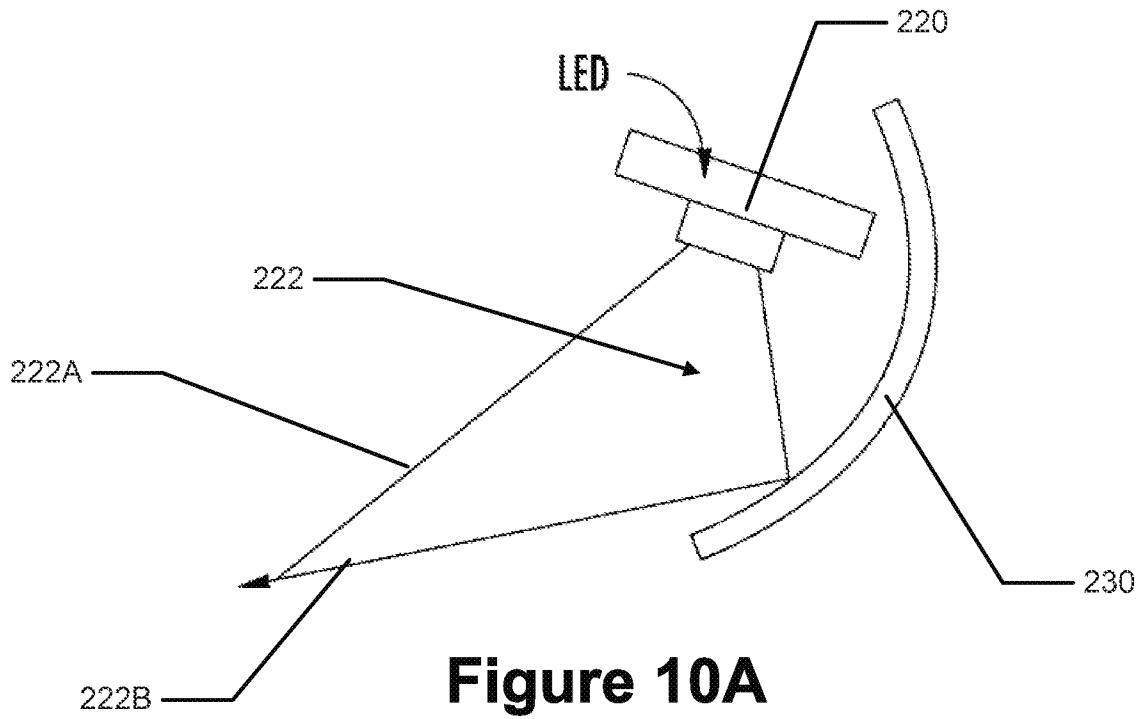
**Figure 9A**

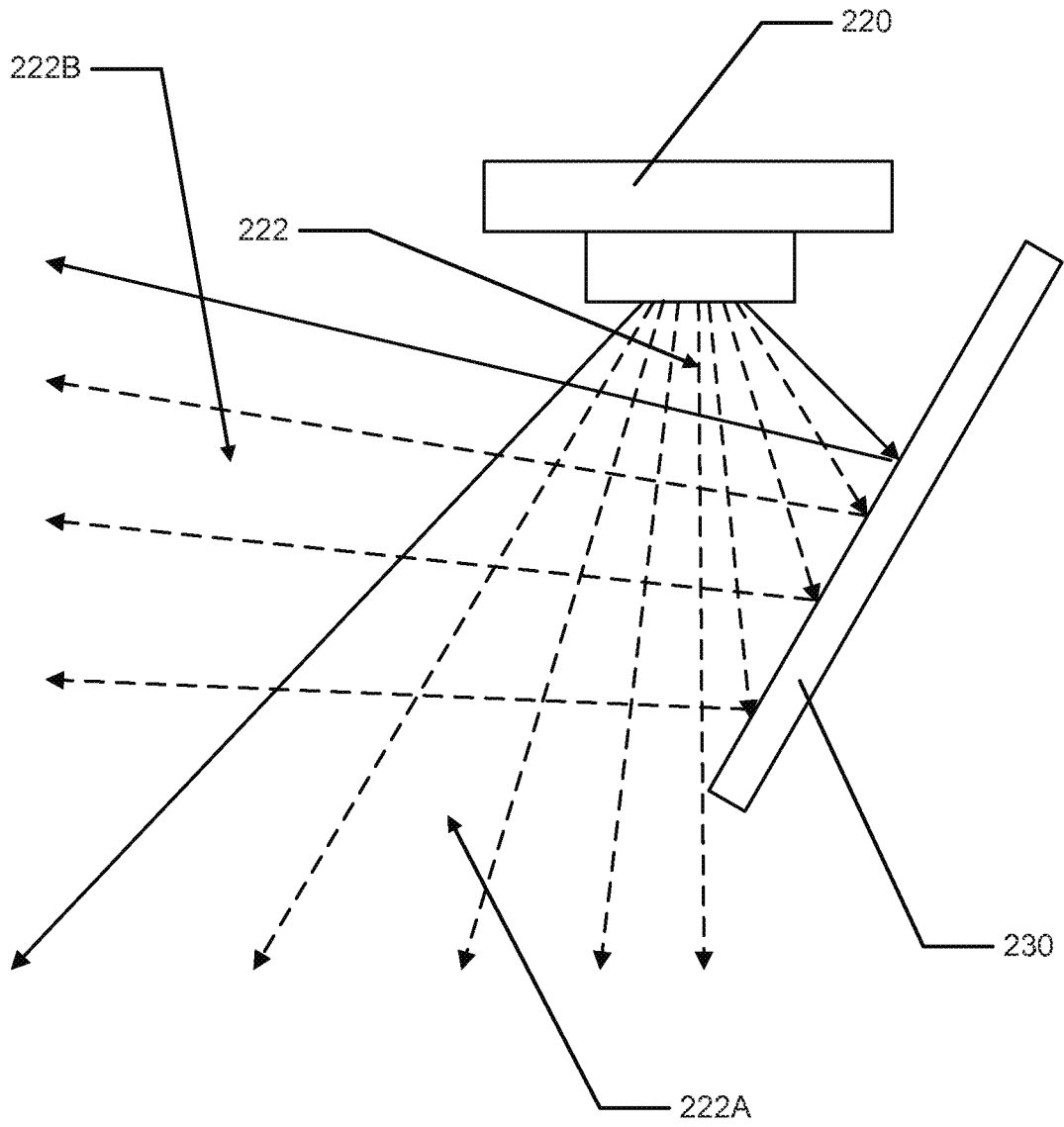


**Figure 9B**

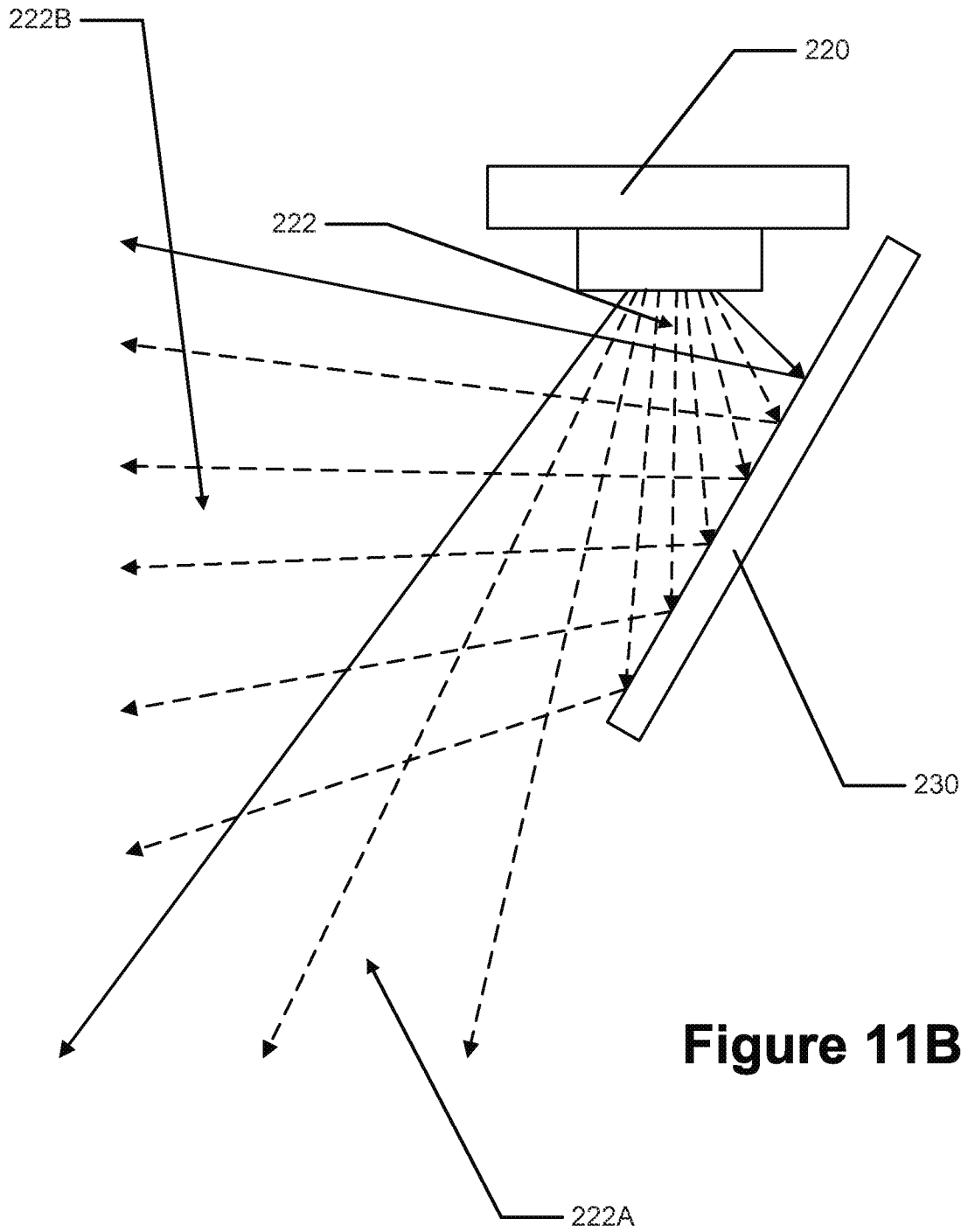


**Figure 9C**



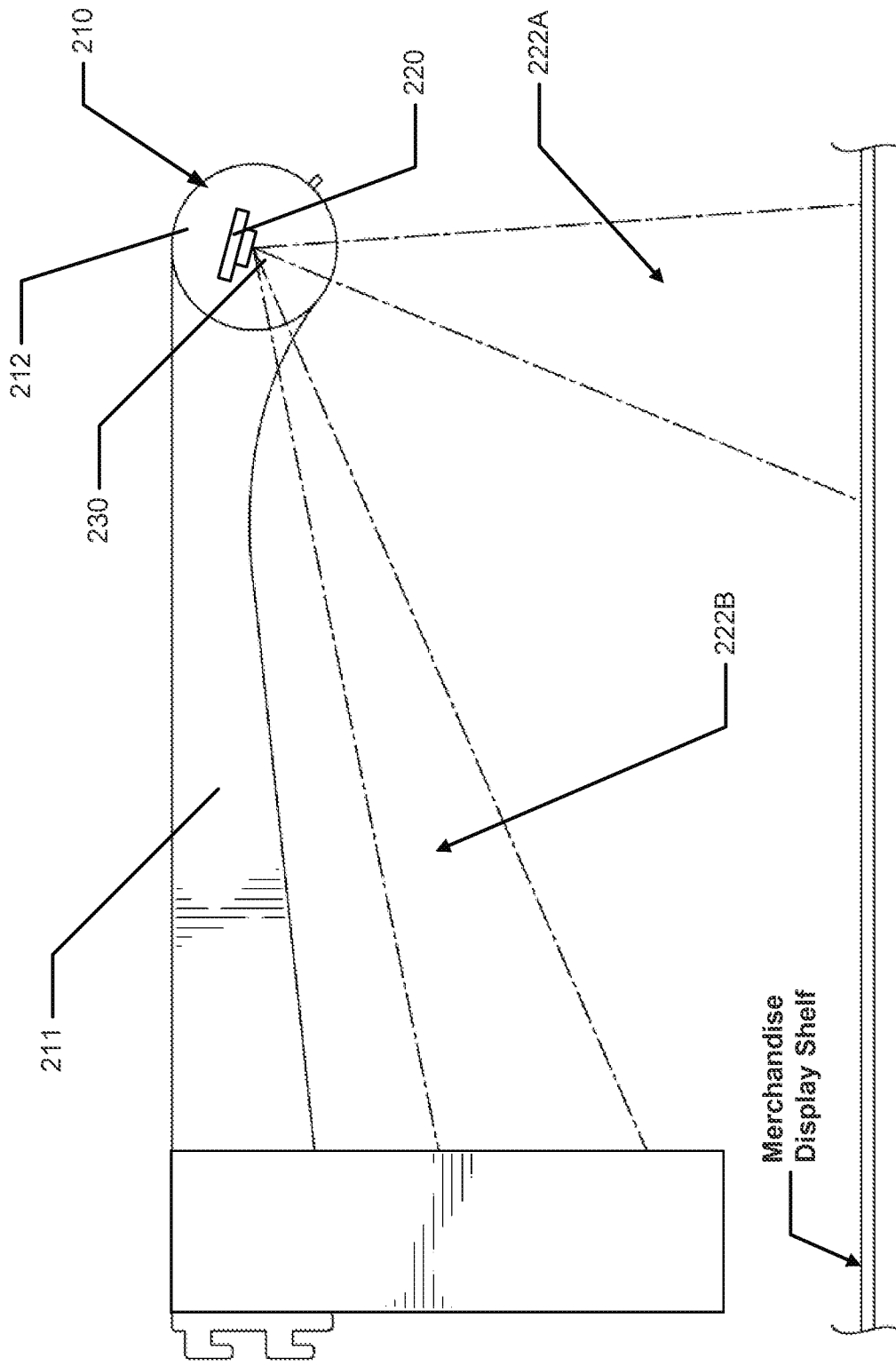


**Figure 11A**



**Figure 11B**





**Figure 12**