

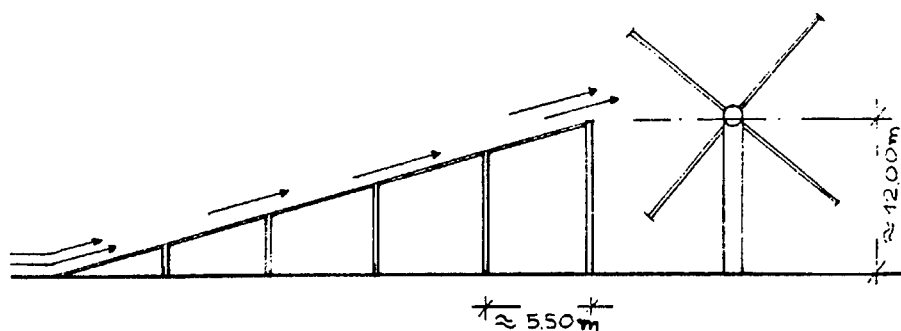

INTERNATIONAL APPLICATION PUBLISHED UNDER THE PATENT COOPERATION TREATY (PCT)

<p>(51) International Patent Classification⁶ : F03D 3/04</p>	<p>A1</p>	<p>(11) International Publication Number: WO 95/08062</p> <p>(43) International Publication Date: 23 March 1995 (23.03.95)</p>
<p>(21) International Application Number: PCT/GR94/00022</p> <p>(22) International Filing Date: 13 September 1994 (13.09.94)</p> <p>(30) Priority Data: 930100377 16 September 1993 (16.09.93) GR</p> <p>(71) Applicant (for all designated States except US): KOFINA, Elvira [GR/GR]; 20 Diamantidou Street, GR-154 52 Palaio Psychico (GR).</p> <p>(71)(72) Applicant and Inventor: KOFINAS, Zacharias [GR/GR]; 13 Kissavou Street, GR-154 52 Palaio Psychico (GR).</p>		<p>(81) Designated States: AM, AU, BB, BG, BR, BY, CA, CN, CZ, FI, GE, HU, JP, KG, KP, KR, KZ, LK, LT, LV, MD, MG, MN, NO, NZ, PL, RO, RU, SI, SK, TJ, TT, UA, US, UZ, VN, European patent (AT, BE, CH, DE, DK, ES, FR, GB, GR, IE, IT, LU, MC, NL, PT, SE), OAPI patent (BF, BJ, CF, CG, CI, CM, GA, GN, ML, MR, NE, SN, TD, TG), ARIPO patent (KE, MW, SD).</p> <p>Published <i>With international search report.</i></p>

(54) Title: SHIELDED WINDMILL



(57) Abstract

The present invention refers to a method and a mechanism for engaging great amounts of aeolian energy and transform it into electric energy by means of a big horizontal, rotating iron shaft 6-20 m long and with a diameter of 16-50 cm. The said shaft is supplied with four rows of frames covered with canvas or nylon sheets. Moreover, the horizontal shaft is furnished with a second rotary motion changing its direction. Two kinds of protective windscreens whose surfaces are covered with nylon or aluminium sheets stapled together form also part of the invention.

FOR THE PURPOSES OF INFORMATION ONLY

Codes used to identify States party to the PCT on the front pages of pamphlets publishing international applications under the PCT.

AT	Austria	GB	United Kingdom	MR	Mauritania
AU	Australia	GE	Georgia	MW	Malawi
BB	Barbados	GN	Guinea	NE	Niger
BE	Belgium	GR	Greece	NL	Netherlands
BF	Burkina Faso	HU	Hungary	NO	Norway
BG	Bulgaria	IE	Ireland	NZ	New Zealand
BJ	Benin	IT	Italy	PL	Poland
BR	Brazil	JP	Japan	PT	Portugal
BY	Belarus	KE	Kenya	RO	Romania
CA	Canada	KG	Kyrgystan	RU	Russian Federation
CF	Central African Republic	KP	Democratic People's Republic of Korea	SD	Sudan
CG	Congo	KR	Republic of Korea	SE	Sweden
CH	Switzerland	KZ	Kazakhstan	SI	Slovenia
CI	Côte d'Ivoire	LI	Liechtenstein	SK	Slovakia
CM	Cameroon	LK	Sri Lanka	SN	Senegal
CN	China	LU	Luxembourg	TD	Chad
CS	Czechoslovakia	LV	Latvia	TG	Togo
CZ	Czech Republic	MC	Monaco	TJ	Tajikistan
DE	Germany	MD	Republic of Moldova	TT	Trinidad and Tobago
DK	Denmark	MG	Madagascar	UA	Ukraine
ES	Spain	ML	Mali	US	United States of America
FI	Finland	MN	Mongolia	UZ	Uzbekistan
FR	France			VN	Viet Nam
GA	Gabon				

SHIELDED WINDMILL

5 The present invention refers to a method and a mechanism destined to engaging great amounts of the aeolian energy existing in abundance throughout the Hellenic State.

10 To date there is only one mechanism or method engaging the aeolian energy, that is the mechanism of the windmills the structure of which, despite the passage of the time, has not altered too much nor has is given encouraging results; this is mainly due to the small amounts of aeolian energy it engages but also to the lack of any further developments in this field. In fact, it is the very method and mechanism used in times passed-by in making small amounts of wheat into flour or pumping water to irrigate a small orchard. This mechanism is currently named wind generator.

20 Engagement of generous amounts of aeolian energy and subsequent transformation thereof into exploitable, uninterrupted, high voltage electric power has not yet been achieved. This would be made possible only if the machine to be used for this purpose met the following requirements:

25 a. to have a great frontal area and the reception of wind to be somewhat unceasing regardless of the direction it is generated.

30 b. to be able to enhance technically any wind velocity, and

c. to be so manufactured as to receive and continuously exploit any aeolian energy within the Beaufort scale. Wind generators made by European companies have failed to meet the three requirements mentioned above; it is for this reason that aeolian energy has not yet reached a satisfactory exploitation level.

The frontal area in currently operating wind generators does not exceed 3 m² whereas, upon exceeding some of the first numbers of the Beaufort scale, the receiving is withheld by brakes in order for likely damages to the wind generator to be avoided. Moreover, the technical enhancement of the wind velocity is far removed from being carried out, not to mention the inability to exploit wind speeds that would not range between 2-5 in the Beaufort scale.

5
10

The advantage of the present invention is that, thanks to the disclosed method and the technical field thereof, a low cost mechanism is offered towards engaging great amounts of aeolian energy in areas having winds of a certain direction and transforming it into electric energy.

15

As results from the description, the claims, and the drawings of the present invention, the three above-stated requirements are fully met; more specifically:

20

1. the frontal area of the surface ranges from 20 m² to some hundreds of square meters and the reception of wind is unceasing regardless of direction due to the capacity of the machine to change direction by rotation at 360°.
- 25 2. any wind speed is technically enhanced on a constant basis.
3. any aeolian energy in the Beaufort scale, even the highest numbers thereof, is received and continuously exploited.

30

In accordance with the present invention, a horizontal, rotating, tubular iron shaft of several meters in length is mounted in its middle by means of ball bearings on a vertical tubular iron machine and at its ends, also by means of ball bearings, on two vertical, tubular iron columns (fig. 1). The said shaft has all along it four rows of rectangular frames made of worked iron 5 cm in

35

thickness vertically attached with respect to its center; the rows are distant from each other by 90° (fig. 2). The frames are covered either with canvas or nylon sheets or again with very thin aluminium sheets. The two
5 extremities of the shaft are supplied with wheels connected respectively to electric power generators.

The method for engaging the aeolian energy and the transformation thereof into electric energy in accordance
10 with the present invention is as follows: a worksite is set up preferably on an island of the Hellenic territory and at a site mostly affected by the winds. After being brought to level, the site is covered with a layer of 20 cm-thick reinforced concrete. At the center of this
15 layer a reinforced-concrete base is constructed of about 3 X 3 m in dimensions (fig. 3). At the center of the base, there seats the base of the vertical tubular machine by means of a great number of bolts. The said machine consists of an iron base of 1.5-2.5 X 1.5-2.5 m
20 in dimensions and 3-5 cm thick. This base has as many holes as the number of bolts planted in the reinforced concrete; it also comprises an external tubular iron casing of 40-60 cm in diameter and of 6-10 meters in height fixed to the iron base of an area about 1.5-2.5 X
25 1.5-2.5. It finally comprises an internal rotating iron pipe sealed at its base of 39.5-59.5 cm or more in diameter and of about 7-11 m in height; the base thereof rests and rotates slowly on big and well greased balls located in three circular grooves positioned in the
30 circular section of the base (of area 1.5-2.5 X 1.5-2.5) housed inside the machine. 70% of the diameter of the said balls is positioned inside the grooves whereas the remaining 30% above the surface of the grooves (fig. 4).

35 The tubular shaft, which is 6-20 m long and has a diameter varying from 16-50 cm, is mounted horizontally

on the top of the slowly rotating vertical tube of the machine. This shaft rests, by means of bearings, exactly in its middle on the top of the slowly rotating vertical tube so as to perform a wide horizontal rotary motion.

5 At about a meter before the end of both sides, the two ends of the horizontal shaft rest, also by means of bearings, on two vertical iron columns, which are 7-11 m high and have a diameter varying from 20-40 cm (fig. 1). These two iron columns on which rest the ends of the

10 horizontal shaft are not fixed on the ground. Two immobile horizontal shafts placed on their lower ends are supplied with four wheels of a slightly tilted arch-like shape in order to follow without causing friction the circular iron rails of 360° on which move these two iron

15 columns (fig. 5).

By this system, the big horizontal shaft can change orientation in circular sense by 360°. The big horizontal shaft has throughout its length and in the

20 section between the two iron columns, except for a small section of 40-50 cm at the point it rests on the top of the internal rotating iron tube of the machine, four rows of rectangular frames made of worked iron, 5 cm in thickness at four points of its periphery which are

25 distant from each other by 90°. These frames, fixed to the horizontal shaft, are not one-piece but divided into smaller pieces for better and more secure support; the dimensions of these frames vary from 6-10 m in height and are of 2 m in width. They are made of worked iron with

30 dimensions of 5 X 5 cm at the top and 5 X 50 cm at the base (fig. 6).

The big horizontal shaft is a cylinder 6-20 m long and 16-50 cm in diameter. Four points of its periphery,

35 distant by 90° between each other, are the ones used as support for the base of each of the four frames (fig. 9).

These frames are positioned in a linear manner on one of the four sides of the shaft, each side being distant from the other by 90° (fig. 2) and varies in length and height.

5

In order for each frame to be more stably fastened to the horizontal shaft and more easily placed thereto, it is divided into smaller frames of about 2 m. Three or four rows of the said smaller frames are placed on the right of the top of the vertical machine whereas another group of equal rows on the left of the vertical machine; the height of the frames varies between 6-10 m (fig. 7).

10

Each frame is fastened as follows:

15

- the base of the frame is reinforced underneath with a blade equal in length and width with those of the frame (about 2 m and 5 cm respectively); the said blade bears a smaller blade of 30 cm in length and 5 cm in width attached to three points thereof. This smaller blade is attached in an upright position to the blade of 2 m thus forming with it a T-shaped construction (fig. 8). Three slots of 32 cm in length on the horizontal shaft are meant for the insertion therein of a 5 cm part of the smaller blade; there follows fixing by welding of the whole frame base against the horizontal shaft.

20

25

- the first fastening is reinforced by an additional one carried out by four joints, each having a semi-circular and two end straight sections (fig. 9). The semi-circular section of the joint rests on the horizontal shaft whereas the end straight sections embrace each side of the two frame bases and are of about 50 cm in length; then they are fixed by screws to the base of the frames which is also of about 50 cm in length (fig. 10). The fixing of the four joints to the bases of the four frames forms a hoop welded against the horizontal shaft and the frame bases. In this way, the horizontal shaft

30

35

along with the bases of the four frames and the four joints are made a solid body (fig. 11); such a hoop is to be placed at about every 50 cm on the horizontal shaft.

5 There is a third fastening carried out as follows:
- the four rows of frames are joined to each other by means of guy wires thus forming a fixed, rectangular square frame preventing the ends of the frames from moving. Similar square frames made of guy wires are
10 placed at three points of the frames (fig. 12).

One to four wheels of variable radius are attached to the ends of the horizontal shaft, specifically 30 cm and more beyond each tubular iron column (fig. 13). At the outer
15 side of each tubular iron column at a distance of 30 cm and more, there are two to four parallel circular rails 360° fixed to the ground. A low open small car destined to carry the generators moves on these rails, which car is furnished with four wheels identical to those of the
20 iron columns, i.e. they are of a slightly tilted circular form (fig. 18). The two small cars are firmly fixed by means of multiple supports to the vertical tubular iron columns. The cars with the generators follow the course of the rotation of the vertical tubular iron columns.

25
It was mentioned above that the horizontal shaft is furnished with wheels at its ends; each wheel is connected to the central shaft of each generator transferring in this way the rotary motion of the
30 horizontal shaft to that which finally transforms it into electric power.

The disclosed part of the invention concerns the engagement of the aeolian energy with the use of a big
35 rotating horizontal shaft mounted by its center on a slowly rotating tubular machine whereas by its two ends

it is seated on tubular iron columns slowly moving on wheels following a circular path of 360°. The horizontal shaft, except for a small section by its center, bears on its four sides by 90° four rows of frames by 1/2 or 2/3 of their length and specifically at the section by the periphery of the frame, which frames are covered with canvas, nylon or thin aluminium sheets (fig. 17). The four rows of frames, two of which are located over and two under the horizontal shaft, receive the aeolian energy (fig. 2).

The method described below discloses the way of carrying out the invention in order to obtain full exploitation of the aeolian energy received by the upper two rows of frames on the horizontal shaft and to eliminate fully the aeolian energy received by the lower two rows of frames on the horizontal shaft. The aeolian energy received by the lower two rows of frames on the horizontal shaft is exploited in the following method:

The amount of aeolian energy received by both rows of frames on the horizontal shaft is almost equal, with only a slight difference over the upper row on the horizontal shaft due to its more elevated position with respect to the ground. This difference provides only a small amount of positive rotating motion to the horizontal shaft. In order to compare the amount of aeolian energy received by the upper and the lower rows of frames on the horizontal shaft, the following grading takes place: assume that the value 100 is the amount of the aeolian energy received by the two upper rows of frames; this aeolian energy results positive because it makes the horizontal shaft rotate. The value 90 is assumed for the lower rows of frames on the horizontal shaft. This grading is correct due to the height difference with respect to the ground. This second amount of aeolian energy results negative because

it eliminates the amount of the aeolian energy received by the upper two rows of frames on the horizontal shaft. The derived value 10 ($100 - 90 = 10$) is the only positive aeolian energy engaged and eventually transformed into motion.

In order to overbalance the above fact, the invention presents a method entirely eliminating the negative aeolian energy and transforming a percentage of 20-30% thereof into positive energy. In accordance with the present method, the amount of aeolian energy received by the two upper frames on the horizontal shaft is the only one, positive, and by 20-30% greater than the normal. The said method is as follows:

Parallel to the horizontal rotating shaft and at a distance equal to the length of the blades, a row of Π -shaped iron or worked iron columns is positioned in linear arrangement; the length of the row is equal or almost equal to that of the horizontal shaft. The columns will be distant from the rotating tubular machine of the center and the two tubular iron columns outwards at half the horizontal shaft slightly increasing. These columns are joined to each other by horizontal iron beams and Π -shaped or worked-iron supports. A second row of columns identical to the first one is positioned at a relative distance from the first; this second-row columns are shorter than those of the first row. Then a third row is positioned at a relative distance from the second; the columns of this row are shorter than those of the second row. The last row is seated on a horizontal beam placed slightly over the ground (fig. 15, 16). The purpose of this arrangement is the formation of an inclined surface in front of the horizontal rotating shaft; the base of this surface is located slightly over the ground whereas its top is the horizontal beam joining

the tops of the first-row columns. The columns of this inclined surface are not firmly fixed on the ground but each column row is supplied with wheels moving on iron rails by 360° having as their center the vertical rotating machine.

The 360° rotation follows the motion of the horizontal shaft and is transferred by it and by the two vertical rotating iron columns by means of multiple supports and a motor (fig. 15, 16). The inclined surface is covered either with nylon or thin aluminium sheets. The aeolian energy affecting the inclined surface is the one that would be received by the lower rows of frames on the horizontal shaft. The inclined surface not only does not absolutely hinder the aeolian energy from affecting the lower frames on the horizontal shaft but also drives the aeolian energy with enhanced power against the upper rows of frames on the horizontal shaft.

Two windscreens are also placed; a section thereof is rotary and seats on the outer divergent sides of the inclined surface whereas the other section thereof is fixed on the ground with its open and large side towards the direction of the proper winds. These windscreens are made of iron, are variable in length, and 1-2 m higher than the height of two blades. The windscreen surface is covered with nylon or thin aluminium sheets (fig. 15, 16). The windscreens are meant to collect the aeolian energy flowing within the space between them and direct it towards the upper rows of frames on the horizontal shaft. The aeolian energy received by the upper rows of frames is much greater than that normal whereas the velocity of the wind is higher. It is easily understood that the produced electric energy is greater as well.

35

It has been mentioned before that on the horizontal

rotating shaft there are four rows of blades distant by
90° between each other. Each row is divided into two
sections, one located on the left and the other on the
right of the vertical shaft; The surface of these
5 sections is flat and half of it, the part towards the
top, is covered with nylon or aluminium sheets whereas
the other half thereof remains uncovered (fig. 17).
A smaller blade, with length equal to half the width of
the blade and height more than 20 cm, is placed on the
10 worked iron surfaces of the two vertical external
sections and the horizontal upper section of each row
(fig. 17). This additional blade are also covered with
either aluminium or nylon sheets and have a direction
towards the direction of the air (fig. 17).

15

It has been also mentioned that the horizontal rotating
shaft is furnished at its ends with wheels connected to
the generator shafts; the generators are placed in series
on two small open cars. Of these generators only the
20 first is firmly connected to the first wheel of the shaft
whereas the second, the third, and, probably, the fourth
generator are connected respectively to the wheels of the
horizontal shaft as the case may be and equally
disconnected. This is regulated automatically and
25 depends on the velocity of the wind received by the
blades (fig. 18). The automatic connection and
disconnection of the other generators is occasional as
they perform double task; for example, if the wind
received by the blades is 3-5 in the Beaufort scale, only
30 the first generator needs to operate. If the wind is
stronger, the second generator is automatically set in
operation in this way not allowing the horizontal
rotating shaft to exceed a certain number of rotations;
if the wind gets even stronger, then the third or
35 possibly the fourth generator is automatically set in
operation. If the opposite happens, i.e. the velocity of

the wind decreases, then the lastly activated generator is brought to disconnection so that the velocity of the wind remains steady and effective.

5 There are two reasons for the presence of more than one
generators: the first concerns the exploitation of any
velocity of the wind transforming it into electric
energy; the second affects directly the horizontal
rotating shaft to which is acts as a brake in order to
10 keep it moving at a steady number of rotations. This is
also achieved with the generators of the Public
Electricity Company; the difference is that in order to
brake the rotating shaft they consume ready electric
power, a fact that results in the exploitation of light
15 winds only, varying from 3-5 in the Beaufort scale.
Unlike this method, the present invention with the system
of multiple generators and the connection or
disconnection thereof depending on the needs, exploits
all kinds of winds, natural or artificial, transforming
20 them into large amounts of electric energy. In case of a
system breakdown the operating generators serve as a
brake to the horizontal rotating shaft.

Another way of carrying out the invention is that of the
25 horizontal shaft being fixed and not rotating vertically
mounted by bearings on supports seated on a concrete
base; fixed would also be the inclined surface and the
two windscreens which would be placed with a direction
towards that of the stronger winds.

30 The description of the invention is based on an
indicative way of carrying it out and any change or
modification to drawings, sizes, materials used in the
construction and assembly of the invention, if they do
35 not constitute an inventive step fall within the scope
and purposes of the present invention.

Claims

1. Method for engaging aeolian energy and transformation thereof into electric energy by means of generators
5 characterized in that the arrangement consists of a horizontal tubular metal shaft supported in its middle by a vertical, slowly rotating shaft so as to have the capacity to rotate horizontally; at its two ends it is supported by two vertical tubular metal columns (fig. 1)
10 which follow the horizontal rotary motion of the horizontal shaft, as the latter changes direction, rolling on circular iron rails by means of wheels (fig. 5). The horizontal shaft bears on either side of the support point, located in its middle, two fans each
15 consisting of four flat frames/blades fixed along the shaft at an angle of 90° between each other (fig. 2). The ends of the horizontal shaft are supplied with wheels (fig. 13) which by means of belts convey the rotary motion of the horizontal shaft to the generator shaft;
20 they are designed to follow the rotary circular motion of the horizontal shaft. The whole system seats on a reinforced concrete base at the perimeter of which there is an inclined surface some meters higher than the horizontal shaft (fig. 15), which surface is almost
25 seated on the ground. The inclined surface is destined to offer protection from the wind to the lower half of the frames and to enhance the wind before driving it towards the upper half of the frames on the horizontal shaft (fig. 15, 16). The inclined surface, covered with nylon
30 or thin aluminium sheets, performs a rotary path of 360° on the iron rails following the course of the horizontal rotating shaft. On either side of the inclined surface there are two divergent vertical windscreens covered with nylon or thin aluminium sheets. The height of the
35 windscreens is equal or greater than that of two fans whereas its length is variable. A section of each

windscreen, actually the one by the worksite, is rotary and follows the course of 360° performed by the inclined surface ; the other section of the windscreen is immobile and has a North-Northeast direction. The horizontal shaft is furnished with 1-4 wheels located on either side thereof which wheels are connected to respective generators.

2.Method for engaging aeolian energy and transformation thereof into electric energy by means of generators in accordance with claim 1 characterized in that (fig. 2) along the horizontal shaft there are two fans consisting of flat, metallic frames/blades made of worked iron for more secure support. Each row of the flat frames is divided into six to eight sections, three or four of which are positioned on the left of the seating point of the horizontal shaft onto the vertical shaft whereas the other three or four are positioned on the right thereof. The base of each row of the flat frames, attached to the horizontal shaft and firmly fixed thereon, is placed at a distance of 90° between each other. These blades are covered in their half, at the side facing the periphery, with nylon or aluminium sheets whereas the other half thereof located by the shaft remains uncovered (fig. 17).

3.Method for engaging aeolian energy and transformation thereof into electric energy by means of generators in accordance with claim 1 characterized in that the system (fig. 1) serving for the support of the horizontal shaft in its middle consists of an iron base of 1.5-2.5 X 1.5-2.5 m and 3 cm thick (fig. 3), an external, tubular, iron casing firmly fixed by its base on the iron base of 1.5-2.5 m, and an internal, slowly rotating, tubular iron shaft on the top of which the horizontal shaft is mounted. This internal rotating tubular shaft is housed in the external casing and seats by its sealed base on

three grooved rows filled with big ball-bearing balls and grease (fig. 4).

5 4.Method for engaging aeolian energy and transformation thereof into electric energy by means of generators in accordance with claim 1 characterized in that the two iron columns used to hold the horizontal rotating shaft by its ends are not fixed on the ground but are seated and move slowly by means of four wheels located at the
10 base of each iron column on two circular iron rails by 360°.

15 5.Method for engaging aeolian energy and transformation thereof into electric energy by means of generators in accordance with claim 1 characterized in that either side of the two ends of the horizontal rotating shaft is furnished with 1-4 wheels each connected to the shaft of respective generators firmly fastened on a low, open, small car moving slowly on four wheels of slightly arch-like form on iron rails by 360° depending on the
20 direction followed by the horizontal shaft (fig. 2, 5).

25 6.Method for engaging aeolian energy and transformation thereof into electric energy by means of generators in accordance with claims 1 and 3 characterized in that the four rows of frames are fastened to the horizontal shaft by means of three separate arrangements (fig. 8, 9, 10, 11, 12).

30 7.Method for engaging aeolian energy and transformation thereof into electric energy by means of generators in accordance with claim 1 characterized in that it is supplied with an inclined, rotating surface on the perimeter of some more meters higher than the horizontal
35 rotating shaft whereas its metallic base is almost seated on the ground (fig. 15, 16).

8. Method for engaging aeolian energy and transformation thereof into electric energy by means of generators in accordance with claims 1 and 7 characterized in that (fig. 15 and 16) the base of the inclined surface is almost seated on the ground whereas its top is somewhat higher than the horizontal shaft (fig. 16). The entire surface of the inclined rotating surface is covered with nylon or aluminium sheets .

9. Method for engaging aeolian energy and transformation thereof into electric energy by means of generators in accordance with claim 1 is characterized in that (fig. 15, 16) two vertical windscreens are positioned outside the worksite at the periphery. A section thereof is rotary and seated on the outer divergent side of the inclined surface whereas the other section is firmly fixed on the ground with its open and large side having a North-Northeast direction. The said windscreens can be made either of iron or from mixtures of substances showing greater resistance and small special gravity. The same stands for all iron constructions of the present invention (fig. 2). Their length is variable whereas their height is 1 to 2 m greater than that of two blades. The surface of the windscreens is covered with nylon or thin aluminium sheets (fig. 15,16).

10. Method for engaging aeolian energy and transformation thereof into electric energy by means of generators in accordance with claims 1 and 2 characterized in that the horizontal shaft, the inclined surface, and the two windscreens can be immobile and not vertically rotating (fig. 2).

11. Method for engaging aeolian energy and transformation thereof into electric energy by means of generators in accordance with claims 1 and 2 characterized in that half

of the surface of the frames/blades may be covered, preferably the section towards the periphery, whereas the rest of it located by the shaft remains uncovered. The outer sections thereof are slightly folded in (fig. 17).

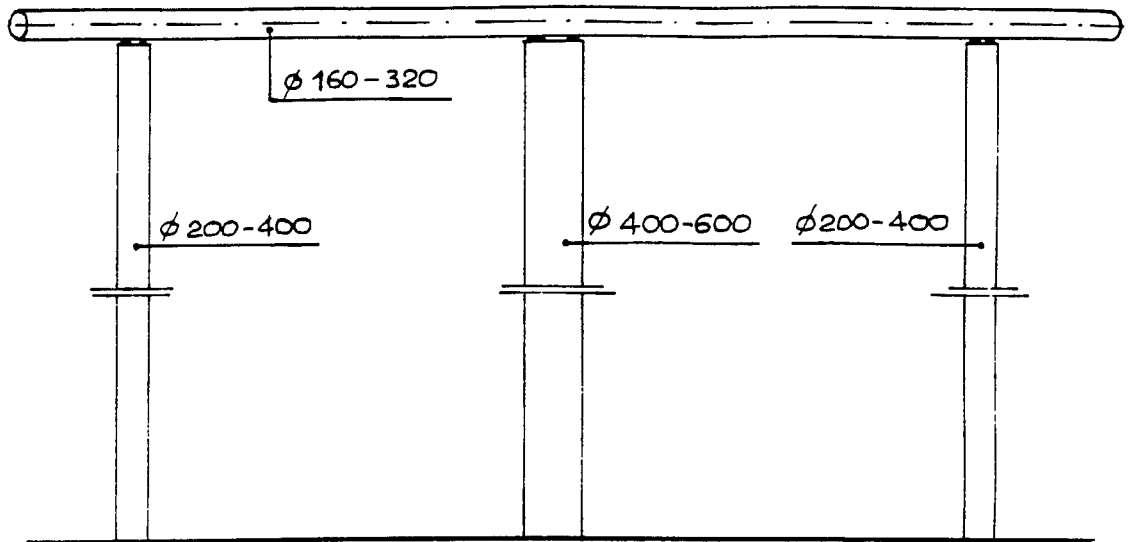

figure 1

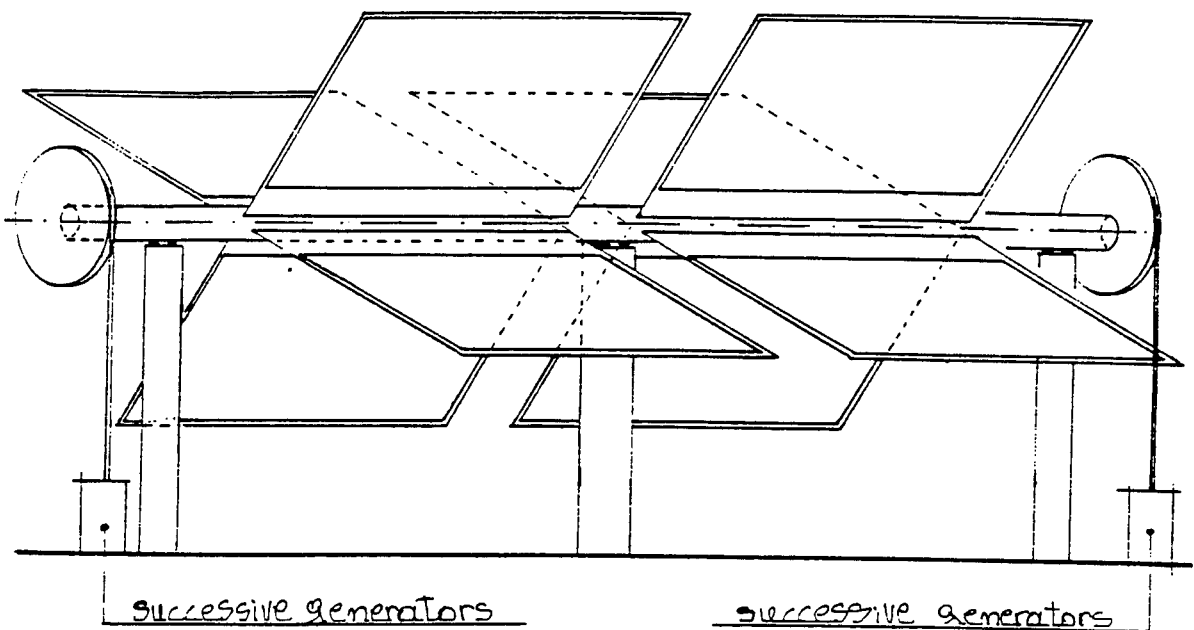

figure 2

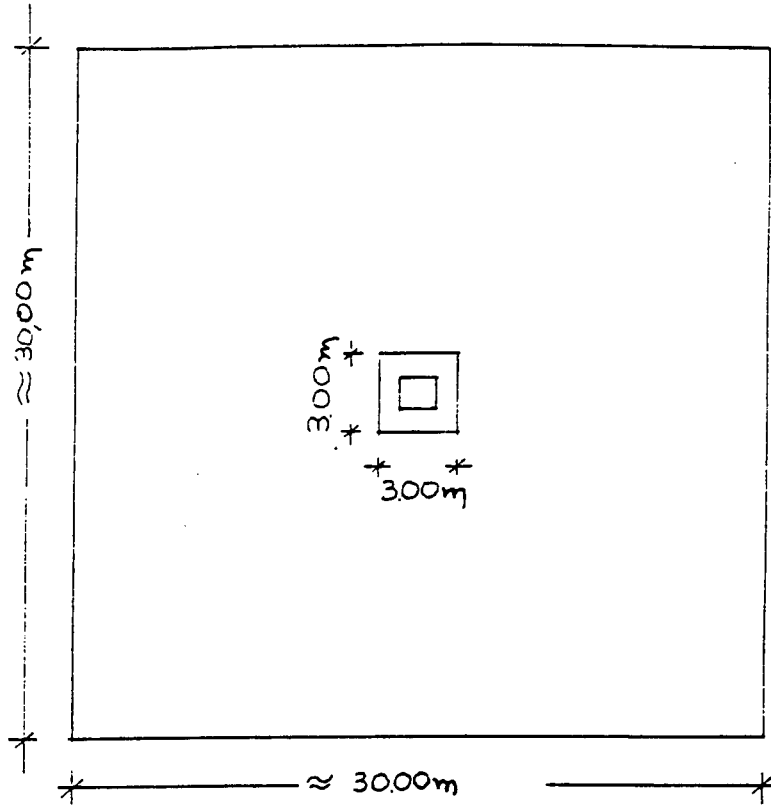

figure 3

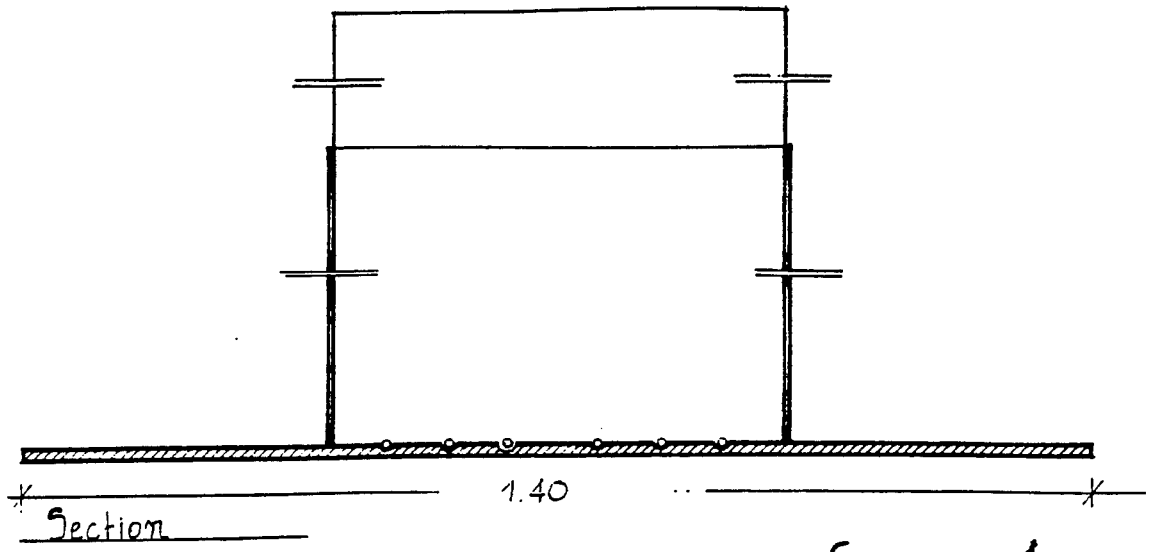
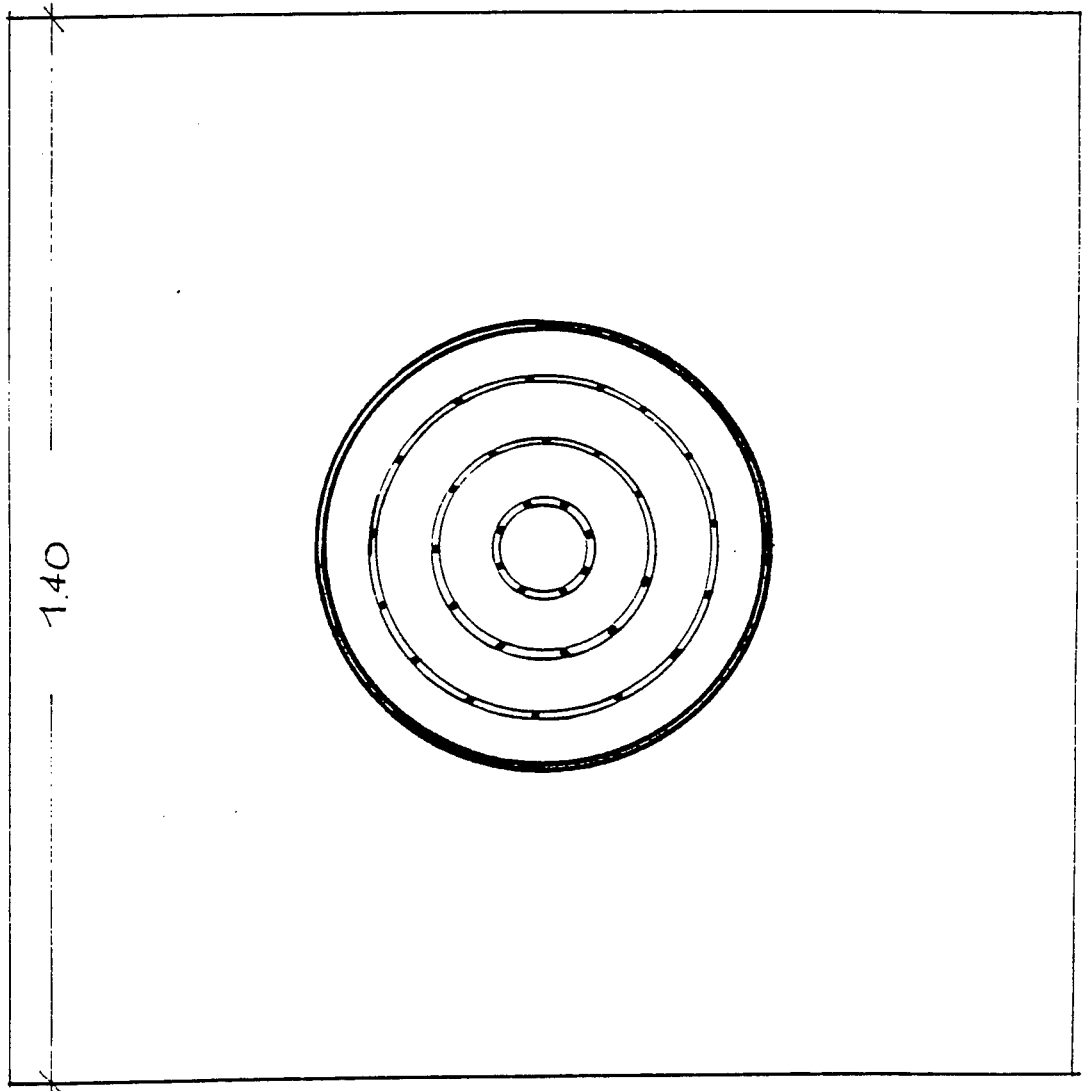

Figure 4

Plan view



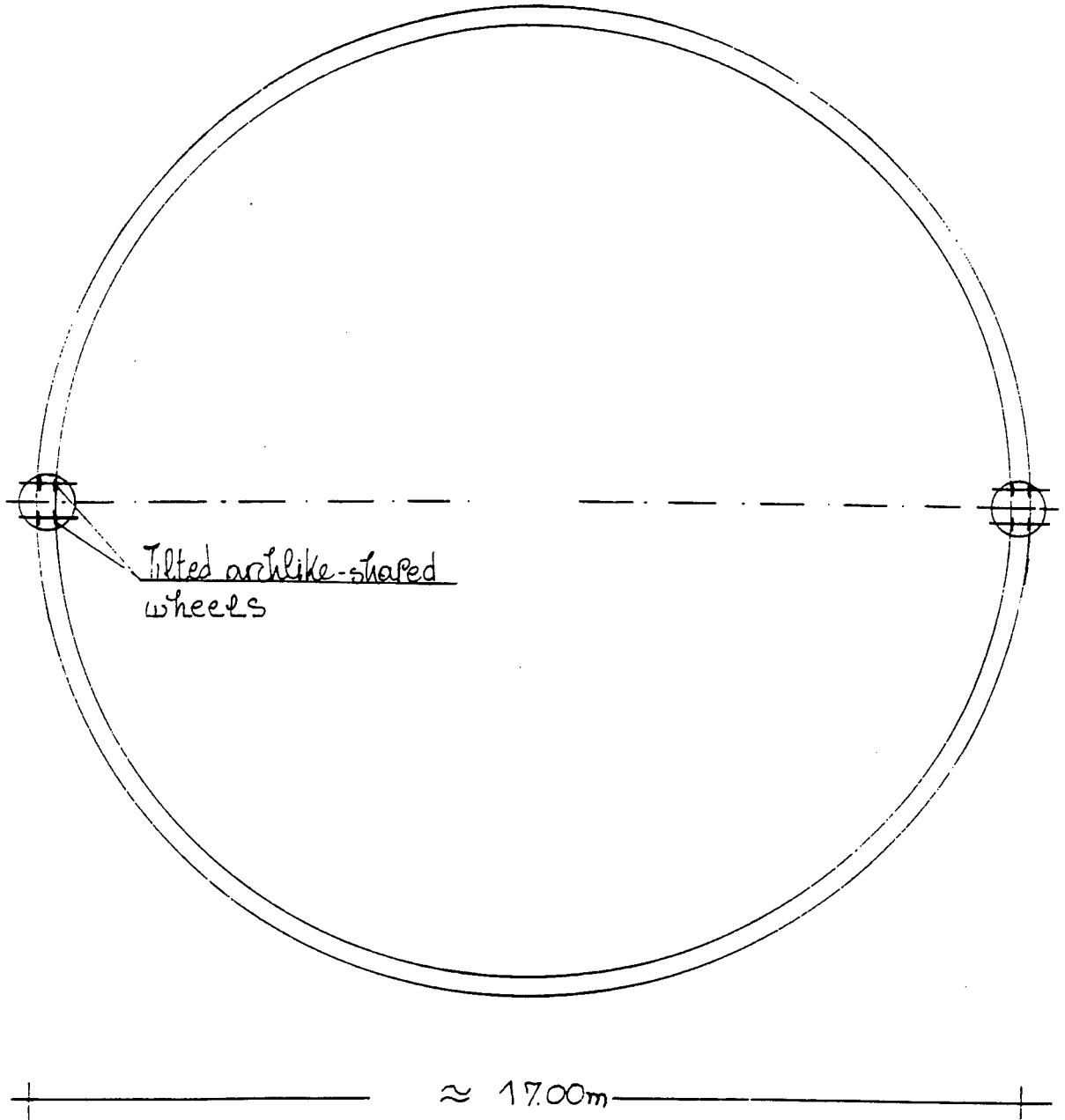

figure 5

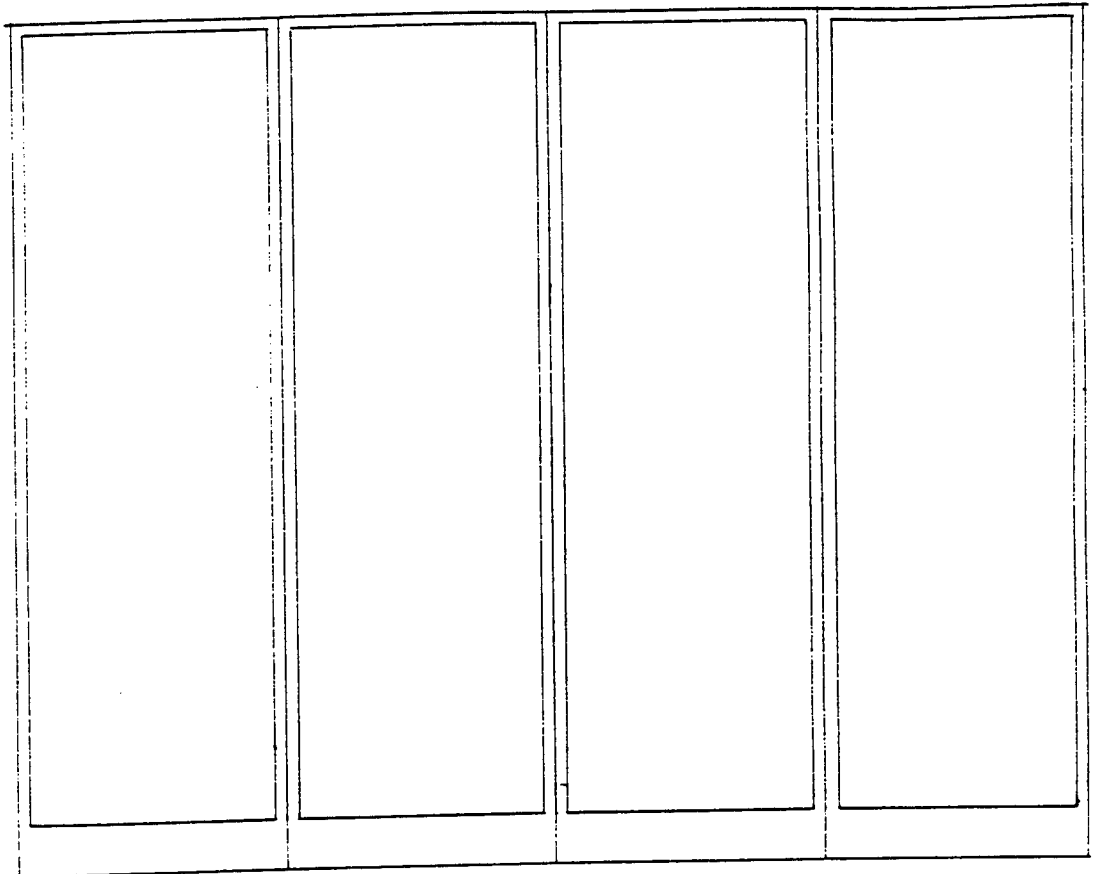

figure 6-7

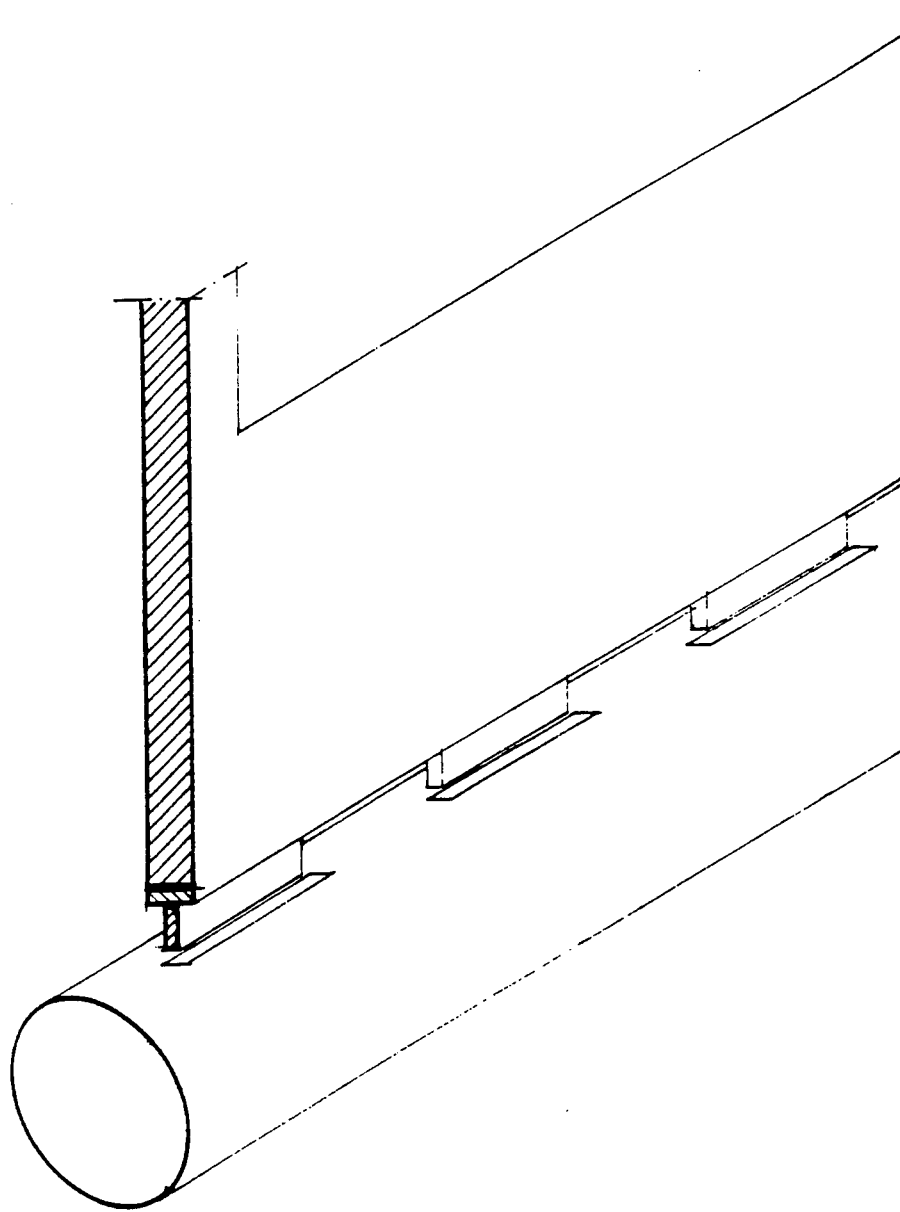

figure 8

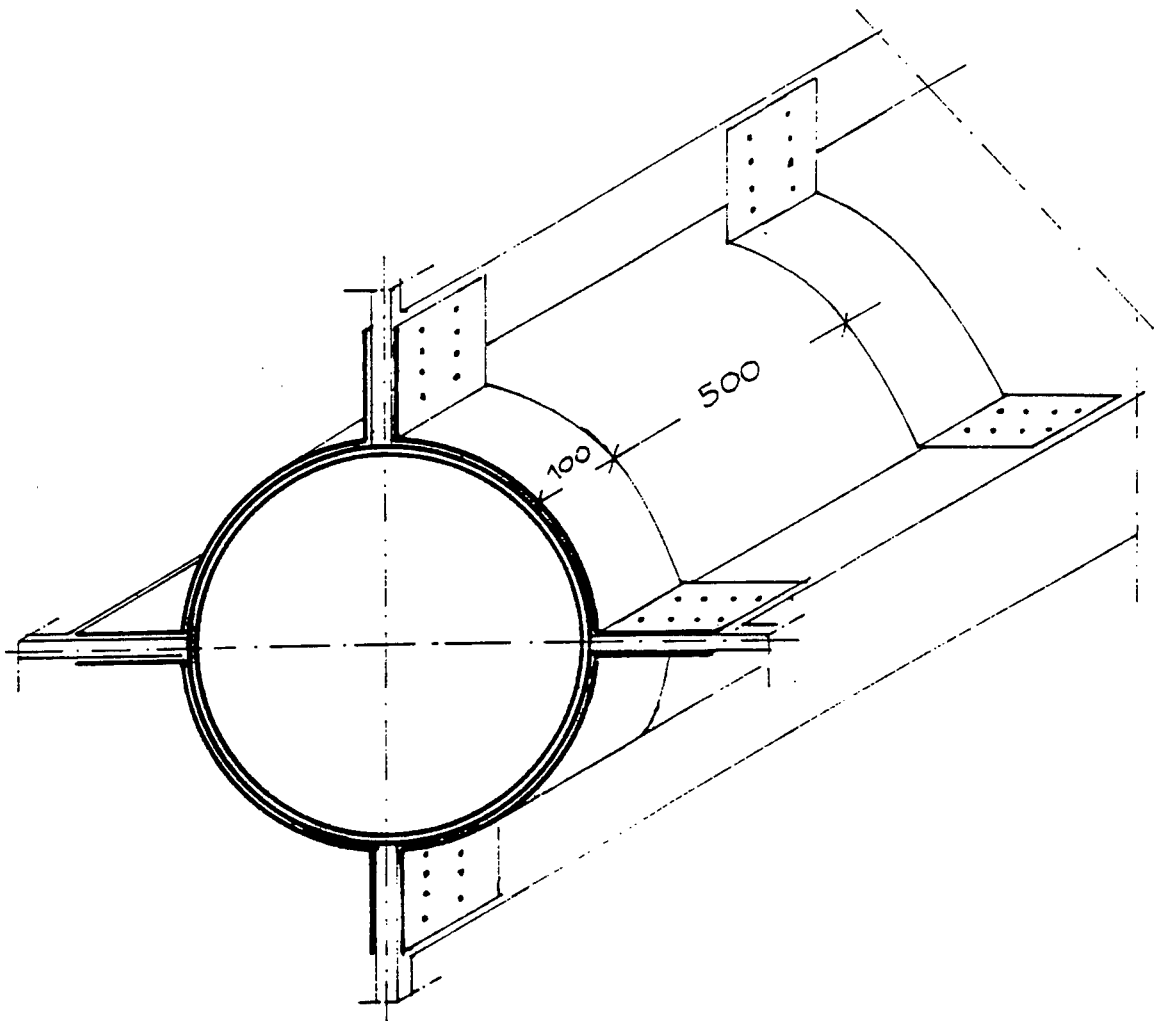

figure 9-10-11

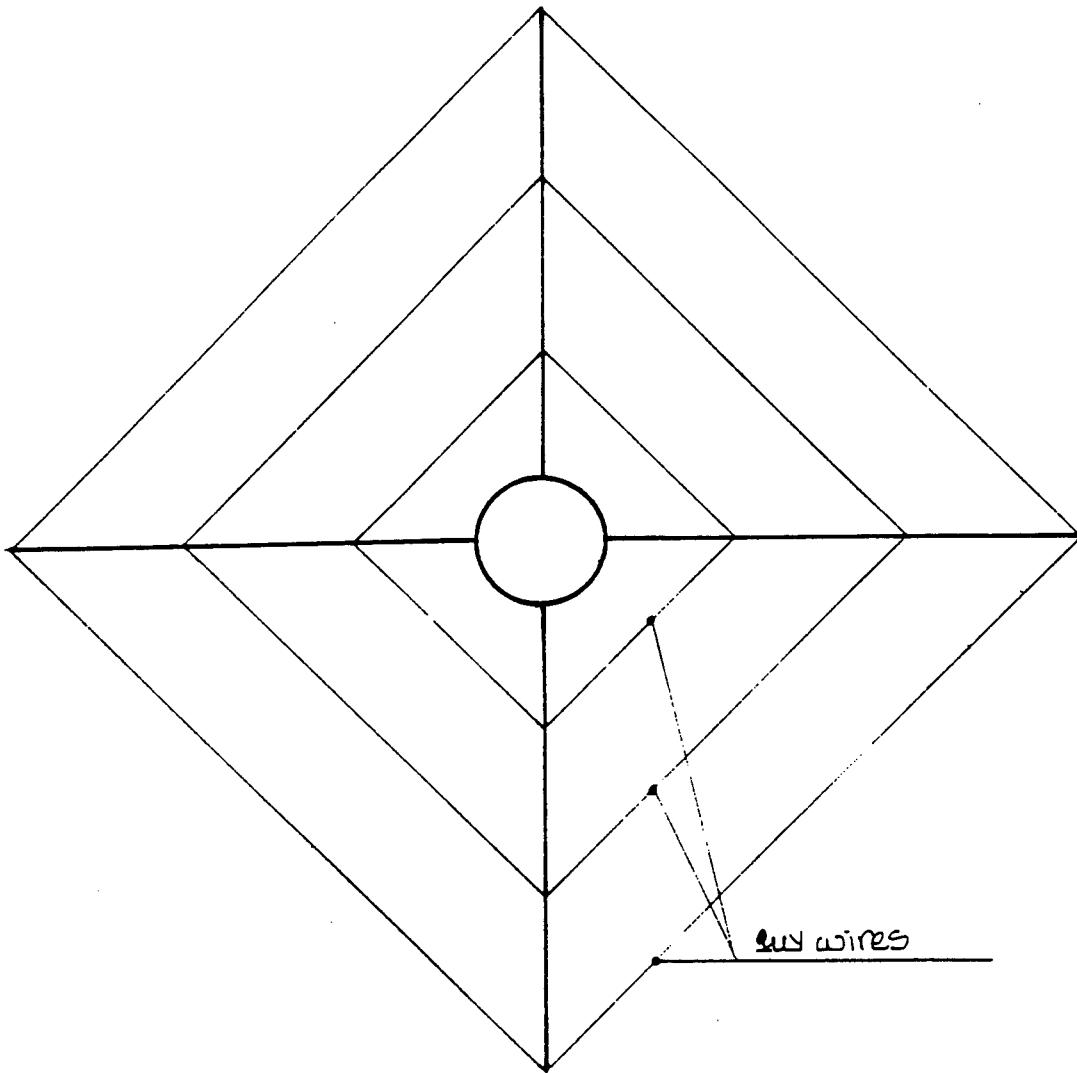

figure 12

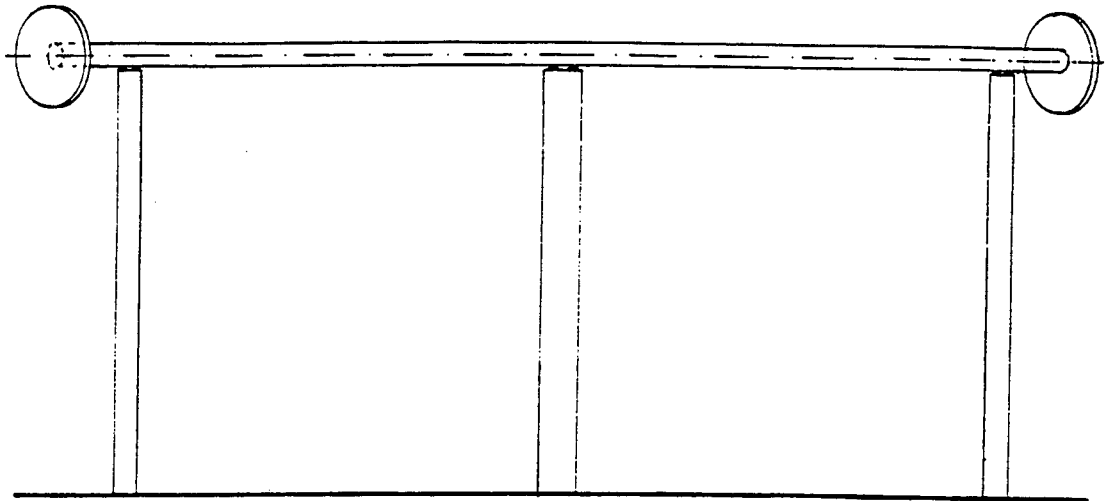

figure 13

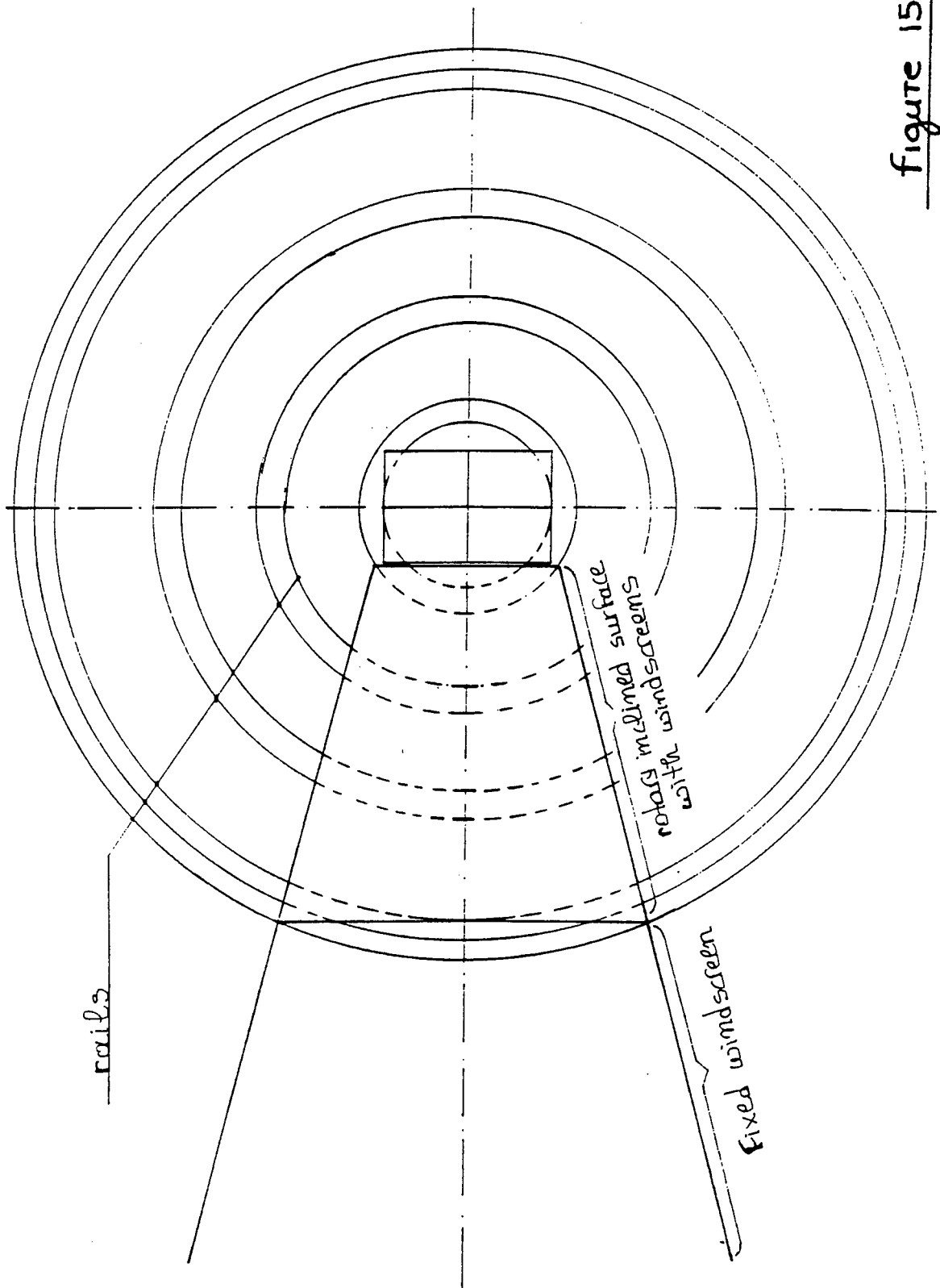

Figure 15

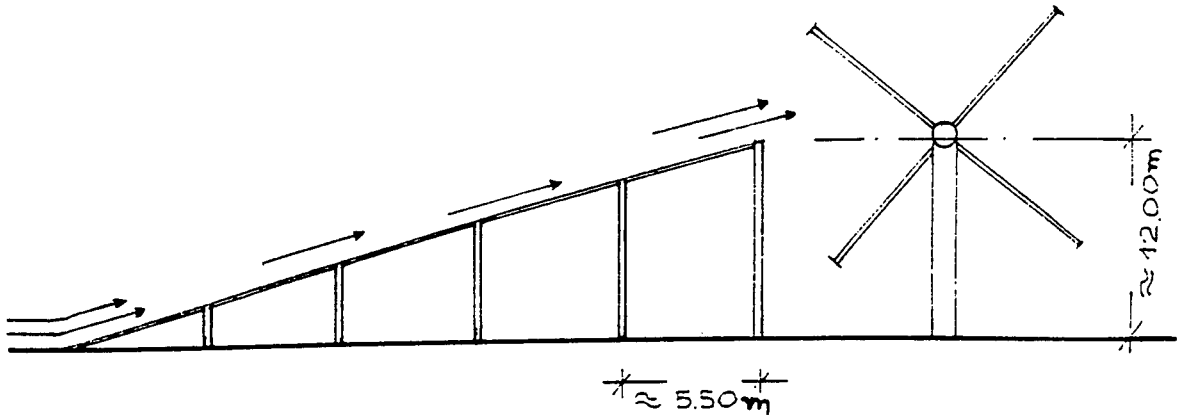

figure 16

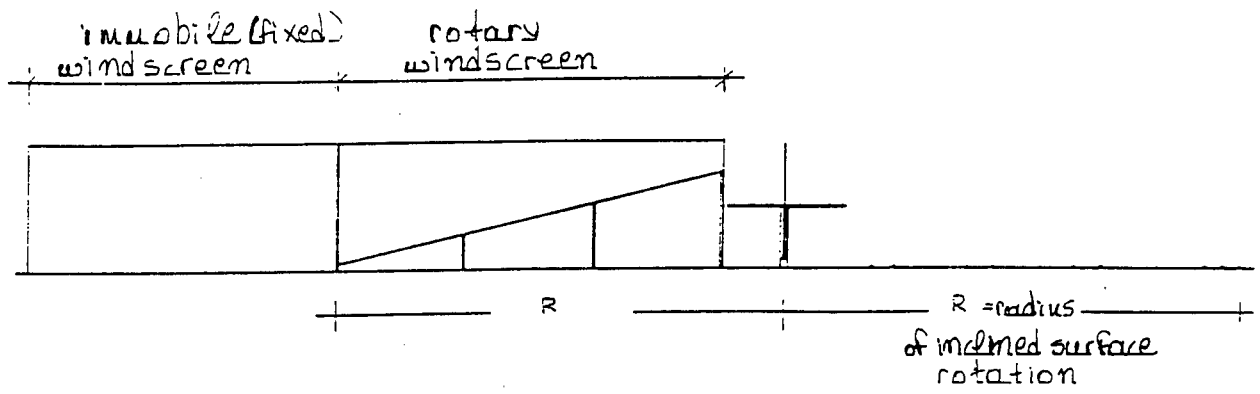

figure 16a

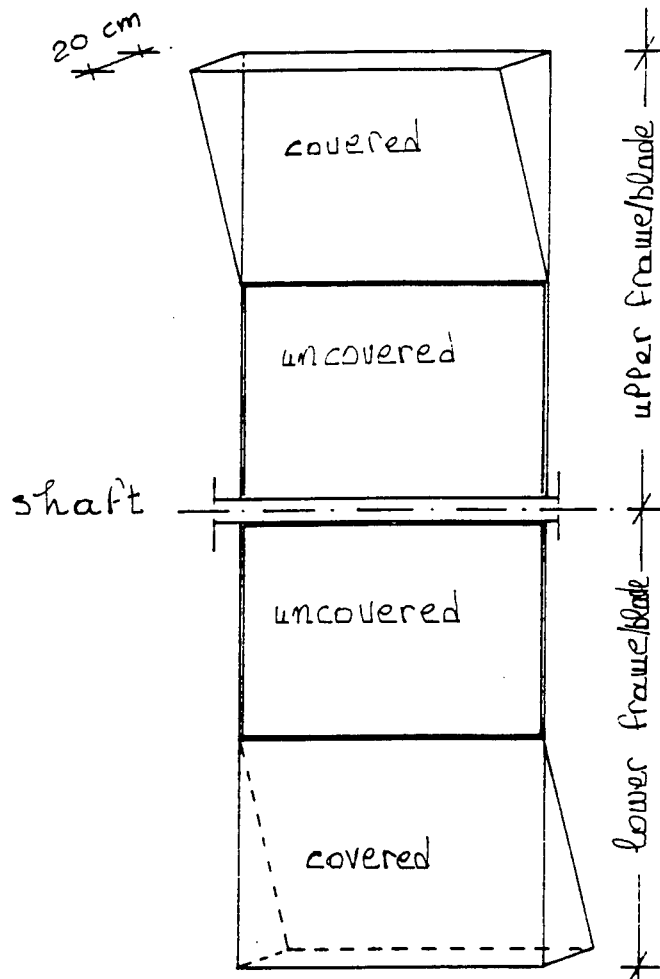

Figure 17

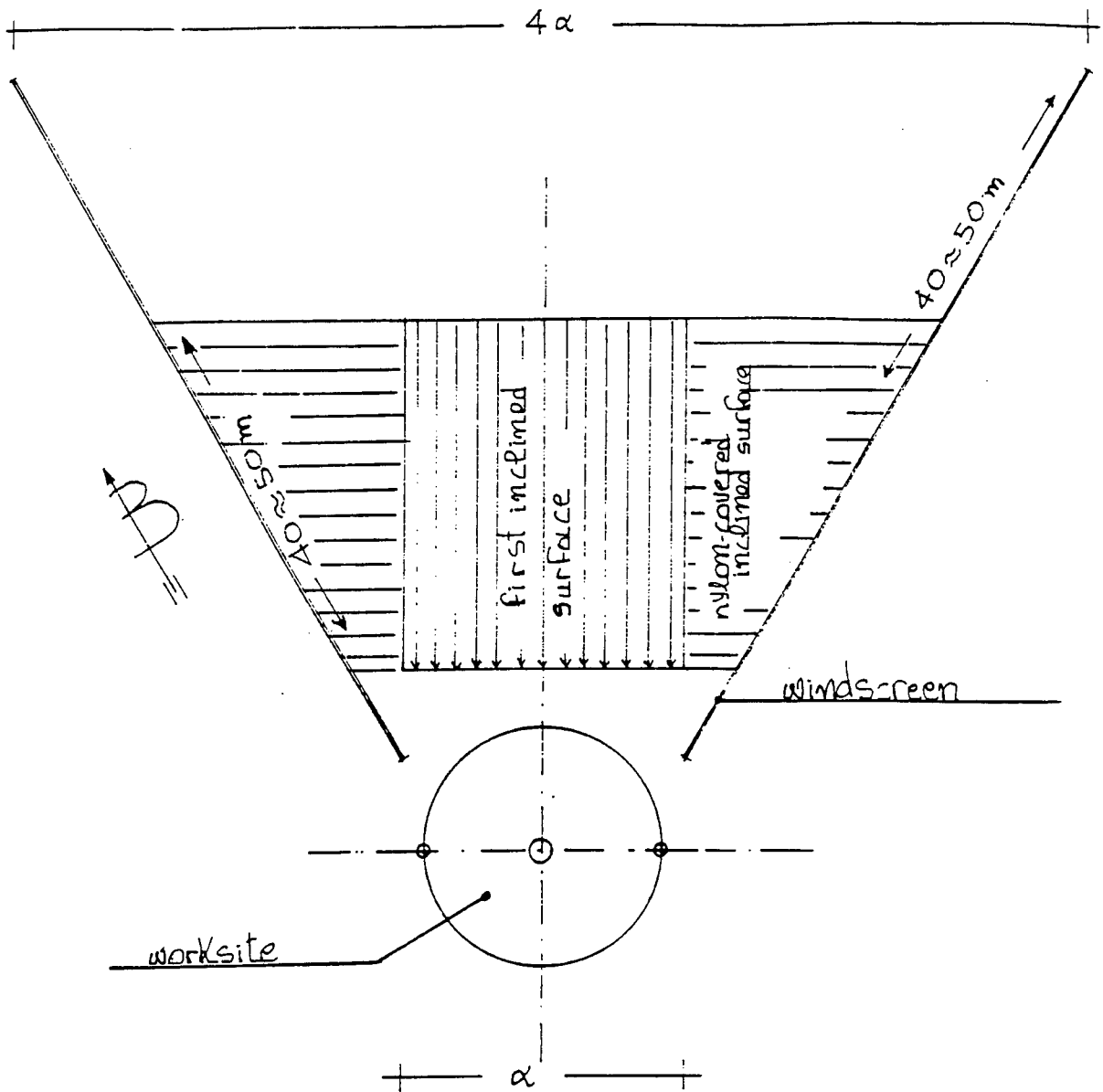

figure 17-18

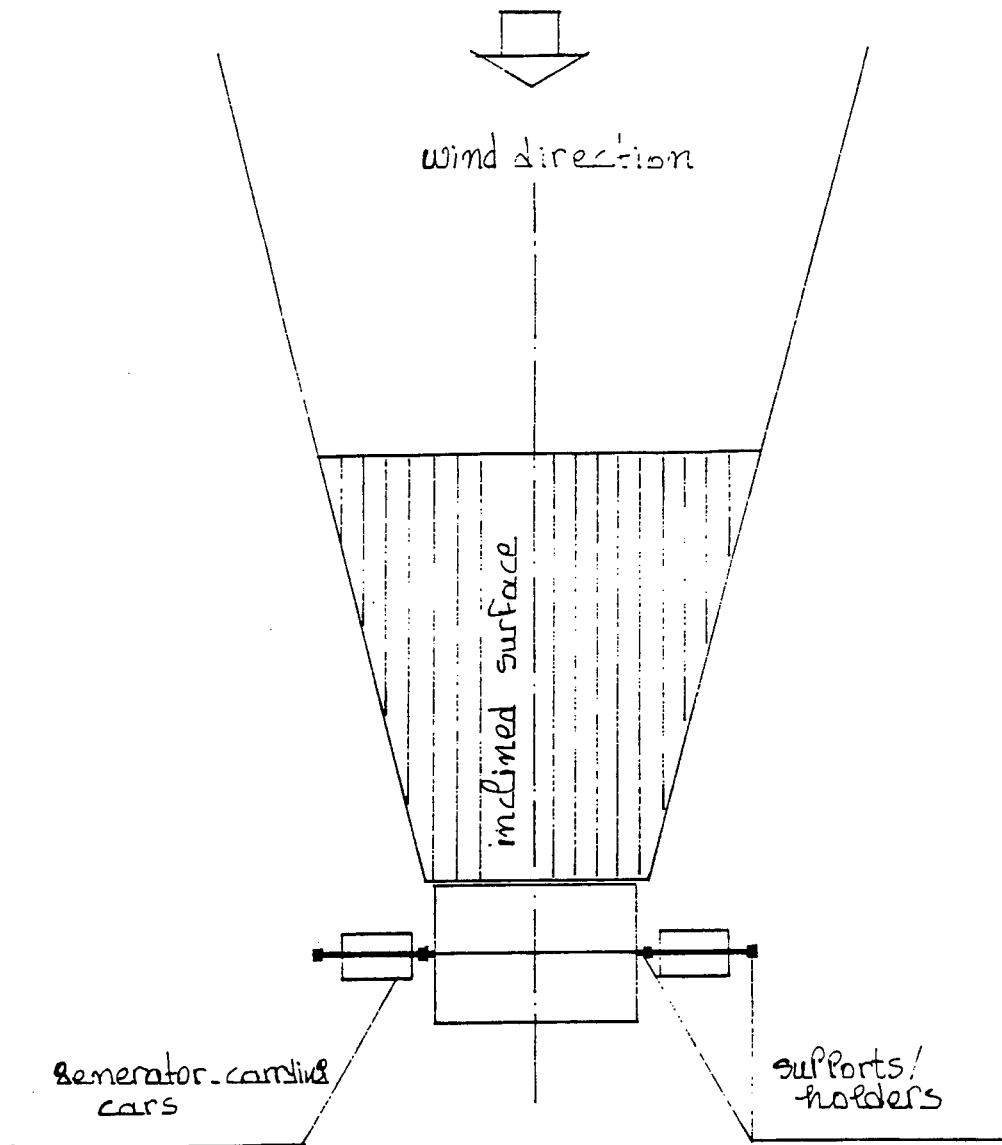

figure 18

INTERNATIONAL SEARCH REPORT

Inter. Application No
PCT/GR 94/00022

A. CLASSIFICATION OF SUBJECT MATTER
IPC 6 F03D3/04

According to International Patent Classification (IPC) or to both national classification and IPC

B. FIELDS SEARCHED

Minimum documentation searched (classification system followed by classification symbols)
IPC 6 F03D

Documentation searched other than minimum documentation to the extent that such documents are included in the fields searched

Electronic data base consulted during the international search (name of data base and, where practical, search terms used)

C. DOCUMENTS CONSIDERED TO BE RELEVANT

Category *	Citation of document, with indication, where appropriate, of the relevant passages	Relevant to claim No.
Y Y	GB,A,110 850 (J.CLEMENS) 21 September 1917 see page 2, line 32 - line 48; figures ---	1-8, 10 9
Y	DE,A,30 27 909 (H.CASPARY ET AL) 11 February 1982 see page 4, paragraph 4 - page 5, paragraph 8; figures ---	1-10
Y	GB,A,667 587 (W.J.HEPPELL) 5 March 1952 see page 1, line 74 - line 77; figure 1 ---	9
A	GB,A,721 926 (A.F.JEAN-MARIE FLAUVEL) 12 January 1955 ---	1
A	FR,A,2 490 285 (N.H.VIGNEAUX) 19 March 1982 see the whole document ---	1
	-/--	

Further documents are listed in the continuation of box C.

Patent family members are listed in annex.

* Special categories of cited documents :

- *A* document defining the general state of the art which is not considered to be of particular relevance
- *E* earlier document but published on or after the international filing date
- *L* document which may throw doubts on priority claim(s) or which is cited to establish the publication date of another citation or other special reason (as specified)
- *O* document referring to an oral disclosure, use, exhibition or other means
- *P* document published prior to the international filing date but later than the priority date claimed

- *T* later document published after the international filing date or priority date and not in conflict with the application but cited to understand the principle or theory underlying the invention
- *X* document of particular relevance; the claimed invention cannot be considered novel or cannot be considered to involve an inventive step when the document is taken alone
- *Y* document of particular relevance; the claimed invention cannot be considered to involve an inventive step when the document is combined with one or more other such documents, such combination being obvious to a person skilled in the art.
- *&* document member of the same patent family

Date of the actual completion of the international search

28 November 1994

Date of mailing of the international search report

14.12.94

Name and mailing address of the ISA

European Patent Office, P.B. 5818 Patentlaan 2
NL - 2280 HV Rijswijk
Tel. (+ 31-70) 340-2040, Tx. 31 651 epo nl,
Fax: (+ 31-70) 340-3016

Authorized officer

Criado Jimenez, F

INTERNATIONAL SEARCH REPORT

Int. Patent Application No
PCT/GR 94/00022

C.(Continuation) DOCUMENTS CONSIDERED TO BE RELEVANT

Category *	Citation of document, with indication, where appropriate, of the relevant passages	Relevant to claim No.
A	DE,A,30 18 435 (A.FLINT) 19 November 1981 ----	
A	US,A,4 204 795 (W.J.FORREST) 27 May 1980 ----	
A	DE,U,83 15 677 (I.SCHÄFER) 2 May 1985 ----	
A	US,A,4 115 028 (A.E.HINTZE) 19 September 1978 -----	

INTERNATIONAL SEARCH REPORT

Information on patent family members

International Application No

PCT/GR 94/00022

Patent document cited in search report	Publication date	Patent family member(s)	Publication date
GB-A-110850		NONE	
DE-A-3027909	11-02-82	NONE	
GB-A-667587		NONE	
GB-A-721926		NONE	
FR-A-2490285	19-03-82	NONE	
DE-A-3018435	19-11-81	NONE	
US-A-4204795	27-05-80	US-A- 4357130	02-11-82
DE-U-8315677	02-05-85	NONE	
US-A-4115028	19-09-78	NONE	