

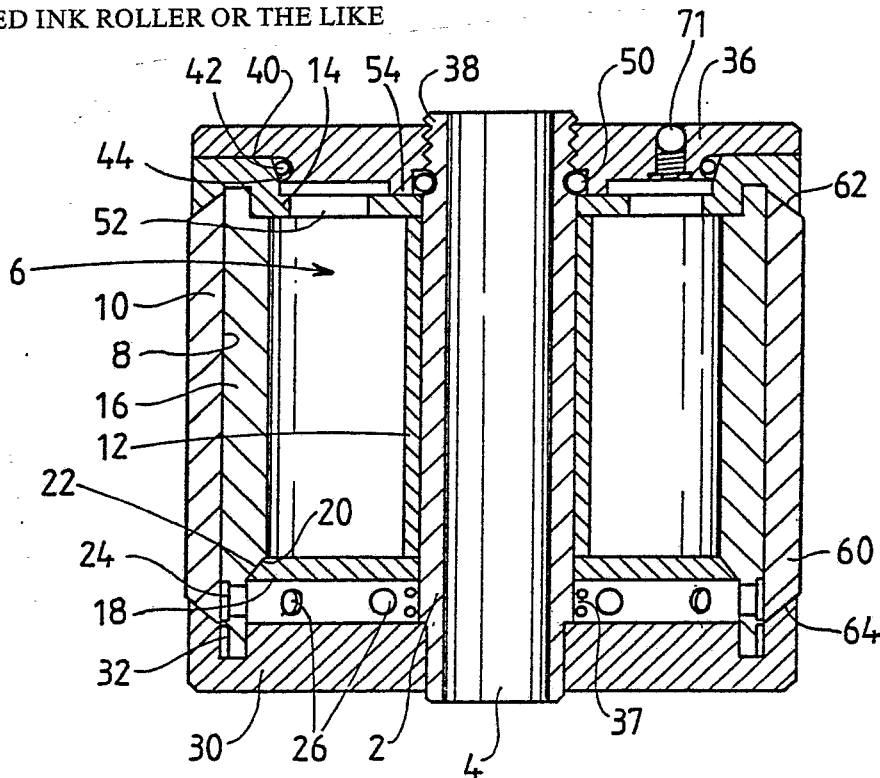

INTERNATIONAL APPLICATION PUBLISHED UNDER THE PATENT COOPERATION TREATY (PCT)

<p>(51) International Patent Classification³ : B41F 31/22, 31/26; B41J 27/12 B05C 1/10</p>	<p>A1</p>	<p>(11) International Publication Number: WO 84/ 00516 (43) International Publication Date: 16 February 1984 (16.02.84)</p>
<p>(21) International Application Number: PCT/AU83/00101 (22) International Filing Date: 3 August 1983 (03.08.83) (31) Priority Application Number: PF 5231 (32) Priority Date: 5 August 1982 (05.08.82) (33) Priority Country: AU (71) Applicant (for all designated States except US): NICHOL INTERNATIONAL PTY. LTD. [AU/AU]; 312 Hoddle Street,, Collingwood, VIC 3066 (AU). (72) Inventor; and (75) Inventor/Applicant (for US only) : NICHOL, Barry, John [AU/AU]; 5 Tudor Road, Doncaster, VIC 3108 (AU). (74) Agents: NOONAN, Gregory, Joseph et al.; Davies and Collison, 1 Little Collins Street, Melbourne, VIC 3000 (AU).</p>		<p>(81) Designated States: AU, BE (European patent), DE (European patent), DK, FR (European patent), GB (European patent), JP, NL (European patent), NO, SE (European patent), US. Published With international search report.</p>

(54) Title: IMPROVED INK ROLLER OR THE LIKE



(57) Abstract

A self-inking roller comprises a main body (6) mounted for rotation on a spindle, a cylindrical porous member (10) disposed on an external surface of the main body (6) with an ink reservoir within said main body (6). An ink distribution path (24, 26, 28) (61, 69, 70) is provided which enables ink to flow from the reservoir to the porous member (10). The ink roller further includes valve means (20, 22) (61, 63) comprising an annular valve seat (22) (61) on the main body (6) and an annular valve element (20) (63). Valve actuating means (36) is provided for moving the valve element (20) (63) relative to the valve seat (22) (61) for controlling the ink flow in the ink distribution path (24, 26, 28) (61, 69, 70).

FOR THE PURPOSES OF INFORMATION ONLY

Codes used to identify States party to the PCT on the front pages of pamphlets publishing international applications under the PCT.

AT	Austria	LI	Liechtenstein
AU	Australia	LK	Sri Lanka
BE	Belgium	LU	Luxembourg
BR	Brazil	MC	Monaco
CF	Central African Republic	MG	Madagascar
CG	Congo	MR	Mauritania
CH	Switzerland	MW	Malawi
CM	Cameroon	NL	Netherlands
DE	Germany, Federal Republic of	NO	Norway
DK	Denmark	RO	Romania
FI	Finland	SE	Sweden
FR	France	SN	Senegal
GA	Gabon	SU	Soviet Union
GB	United Kingdom	TD	Chad
HU	Hungary	TG	Togo
JP	Japan	US	United States of America
KP	Democratic People's Republic of Korea		

IMPROVED INK ROLLER OR THE LIKE

This invention relates to a self inking roller of the type which can be used in conveyor line coders, hand printing rollers, printing presses and other
5 related equipment.

The general object of the present invention is to provide an improved form of inking roller having an internal reservoir for ink and having valve which can be easily actuated so as to effectively prevent flow
10 of ink from the reservoir. Further, the object is to provide a self-inking roller having an internal reservoir which in preferred embodiments can be formed with a central bore right through the roller so that it can be mounted in a stable manner in a variety of
15 different forms of equipment which are provided with spindles for receipt of printing rollers.

According to the present invention there is provided a self-inking roller comprising a main body mounted for rotation on a spindle, a cylindrical
20 porous member disposed on an external surface of said main body an ink reservoir within said main body an ink distribution path which enables ink to flow from



said reservoir to said porous member characterized in that the ink roller includes valve means comprising an annular valve seat on said main body and an annular valve element and valve actuating means for moving the valve element relative to the valve seat for controlling the ink flow in said path.

Preferably the main body includes a substantially cylindrically shaped section and there is further provided a tubular spindle mounting member having a bore therein for receiving the mounting spindle the tubular member being coaxial with the cylindrically shaped section and operatively connected thereto for rotation therewith. Preferably opposed end caps are provided at respective ends of the cylindrically shaped section.

The self-inking roller may further include coupling means operatively connecting the valve actuating means to the valve element. In one form the annular valve seat is disposed near one end of the main body and the coupling means includes a tubular member arranged coaxially with the spindle mounting member and said main body and arranged for axial movement relative to the main body to cause relative movement between the valve element and the valve seat. Preferably the actuating means comprises one of the end caps mounted for limited axial movement relative to the main body by rotation thereof relative to the spindle mounting member.

In one form the flow path may include a circumferential distribution channel at one end of the



main body adjacent the valve means and a plurality of openings in the wall of the main body adjacent the distribution channel permitting ink to flow to the external surface of the main body.

5 In another form the coupling means comprises a cam element mounted between the spindle mounting member and the valve element.

10 Example embodiments of the invention will hereinafter be described with reference to the accompanying drawings in which:

Figure 1 is an end view of one preferred embodiment of the ink roller of the invention,

15 Figure 2 is an axial sectional view of the roller shown in figure 1,

Figure 3 is an exploded view of the roller shown in figures 1 and 2,

Figure 4 is a sectional view taken along the line V-V in Figure 5, and

20 Figure 5 is a sectional side elevation of another preferred embodiment of the ink roller of the invention.

25 Referring to the embodiment described with reference to figures 1 to 3 the illustrated inking roller comprises a central tubular member 2 the bore 4 of which receives in use a mounting spindle (not

shown) for mounting the roller. The tubular member 2 extends within a cylindrical opening formed in a body portion 6. The body portion has a cylindrical wall 8 which serves as a support surface for a porous inking member 10. The interior of the main body portion 6 serves as a reservoir for ink. The body 6 is preferably fabricated from a number of components including an inner tubular member 12 which lies adjacent to the tubular member 2 an annular wall 14 which is connected to the tubular member 12 and a downwardly extending cylindrical member 16 the outer surface of which constitutes the supporting surface 8. The reservoir is closed by a movable annular disc 18 which is located adjacent to the end of the tubular member 12. The annular disc 18 has an oblique face 22 which serves as a valve element and bears against a complementary face 22 formed on the lower part of the cylindrical member 16, the face 22 serving as a valve seat.

The cylindrical member 16 is formed with an ink distribution channel 24 near its lower end, the channel 24 having openings 26 which communicate with the interior of the member 16 beneath the annular disc 18. It will be appreciated that when there is a gap between the valve element 20 and valve seat 22 ink can flow from within the annular ink chamber within the tubular member 16 to the distribution channel 24. The tubular member 16 includes a number of axially extending ink distribution channels 28 which communicate with the circumferential channel 24 and permit flow of ink more or less uniformly to the interior surface of the porous member 10. The lower

end of the body 16 is received within an annular end piece 30, the member 16 being provided with threads 32 which cooperate with complementary threads provided in a groove in the end piece 30. The end piece 30 seals
5 against the tubular member 2 at a reduced diameter portion 34 thereof. A compression spring 37 surrounds the tubular member 2 and acts between the end piece 30 and the annular disc 18 and serves to bias the latter such that the surfaces 20 and 22 engage to thereby
10 prevent flow of ink into the channel 24. Alternatively for example the tubular member 2 may be threaded at its end remote from threaded end 38 and adapted to co-operate with a centrally disposed threaded section on end piece 30. In this arrangement
15 O-rings may be provided to seal the end piece and the tubular member and cylindrical member.

The roller further includes an annular top end piece 36 which is threadably mounted on threads 38 formed on the upper end of the tubular member 2. The
20 end piece 36 effectively forms a closure for the ink reservoir of the roller. The piece 36 is formed with an outer recessed face 40 which provides a seating for an outer O-ring 42 which bears against an adjacent shoulder 44 formed on the upper surface of the annular
25 wall 14. An inner O-ring 46 is provided and it is seated in a groove 48 formed in the tubular member 2 and bears against a shoulder 50 formed adjacent to the inner bore of the end piece 36.

The end piece 36 can be removed from the roller
30 by rotating it so that it moves axially on the threads 38 provided on the tube 2. Once the end piece 36 has

been removed, the ink reservoir can be filled by pouring ink onto the annular wall 14 so that it will run through filling openings 52 provided therein. The end piece 36 may then be replaced and the O-rings 42 and 46 will prevent ink leakage. It will be noted that the end piece 36 includes an annular projection 54 which lies adjacent to the upper surface of the annular portion 14. The arrangement is such that the end portion 36 can be tightened so that the projection 54 will engage and resiliently deflect that member 14 downwardly so that it in turn will cause the surfaces 20 and 22 to separate thereby enabling ink to flow from the reservoir through the openings 26 and into the channels 24 and 28. Untightening of the end piece 36 will have the opposite effect and thus the ink reservoir will again be sealed by contacting of the surfaces 20 and 22. It will be appreciated of course that the valve constituted by the surfaces 20 and 22 is operable more or less independently of the orientation of the roller. It will be further appreciated that the lower end piece 30 can be removed from the body 16 by rotating it so that it moves on the threads 32 provided on the lower end of the body. Once the end piece 30 has been removed, the porous member 10 can be removed by downward axial movement so that it can be serviced and/or replaced. This is also seen as a useful advantage. The member 10 is preferably formed in the annular wall 14 and end piece 30 respectively so as to assist in holding it in position on the surface 8 between the wall 14 and end piece 3.



In the embodiment shown in figures 4 and 5 the inking roller is essentially the same as that shown in figures 1 to 3 except for the arrangement of the valve means and the flow path. As before this roller
5 comprises a central tubular member 2 the bore 4 of which in use receives a mounting spindle. There is also provided a main body 6 having a cylindrical wall 8 and a porous inking member 10.

In this embodiment the valve means comprises a
10 plurality of valve seats 61 around openings 64 the valve seats 61 being axially disposed along the wall of the main body 6. The valve member comprises a tubular section 62 with a plurality of valve stems 63 projecting therefrom each being adapted to co-operate
15 with respective valve seat 61. The valve member is inhibited from relative rotation with respect to the main body 6. The coupling member comprises a cam 65 rotatably mounted between spindle mounting tube 2 and the tubular section 62 of the valve member. The cam
20 65 has a slot 67 therein which is engaged by pin 68 when the cap 36 defining the actuating means has been screwed in sufficiently. This rotation of cam 65 causes valve stems 63 to left of the valve seats 62 permitting passage of ink from the reservoir to the
25 porous member 10. Ink distribution slots which extend both circumferentially 69 and axially 70 of the main body 2 enable the ink to be distributed more evenly to the porous member 10. This embodiment has particular application where the ink roller is relatively long.

30 A pressure relief valve 71 provides communication between the ink reservoir and atmosphere and is



operative should a vacuum be created in the reservoir as a result of the discharge of ink therefrom. The pressure relief valve may be of any suitable form.



CLAIMS:-

1. A self-inking roller comprising a main body (6) mounted for rotation on a spindle, a cylindrical porous member (10) disposed on an external surface of said main body (6) an ink reservoir within said main body (6) an ink distribution path (24, 26, 28) (61, 69, 70) which enables ink to flow from said reservoir to said porous member (10) characterized in that the ink roller includes valve means (20, 22) (61, 63) comprising an annular valve seat (22) (61) on said main body (6) and an annular valve element (20) (63) and valve actuating means (36) for moving the valve element (20) (63) relative to the valve seat (22) (61) for controlling the ink flow in said path (24, 26, 28) (61, 69, 70).
2. A self-inking roller according to claim 1, further characterized in that said body (6) includes a substantially cylindrically shaped section and further characterized by a tubular spindle mounting member (2) having a bore (4) therein for receiving the mounting spindle said tubular member (2) being coaxial with said cylindrically shaped section of said main body (6) and operatively connected thereto for rotation therewith.
3. A self-inking roller according to claim 2, further characterized by opposed end caps (30) (36) at respective ends of said main body (6).
4. A self-inking roller according to claim 3, further characterized by coupling means (12) (65)



operatively connecting said valve actuating means (36) to said valve element (20) (63).

5. A self-inking roller according to claim 4, characterized by said annular valve seat (20) being disposed near one end of said main body (6) and said coupling means (12) being a tubular member arranged coaxially with said spindle mounting member (2) and said main body (6) arranged for axial movement relative to said main body (6) to cause relative movement between said valve element (20) and said valve seat (22).

6. A self-inking roller according to claim 5, further characterized in that said actuating means 36 comprises one of said end caps mounted for limited axial movement relative to said main body by rotation thereof relative to said spindle mounting member (2).

7. A self-inking roller according to claim 6, further characterized in that said flow path includes a circumferential distribution channel (24) at one end of said main body adjacent said valve.

8. A self-inking roller according to claim 7, further characterized in that said distribution path includes a plurality of openings (26) in the wall of said main body adjacent said distribution channel (24) permitting ink to flow to the external surface of said main body.

9. A self-inking roller according to claim 4, characterized in that said coupling means comprises



cam element (65) mounted between the spindle mounting member (2) and the valve element (63).



FIG 1

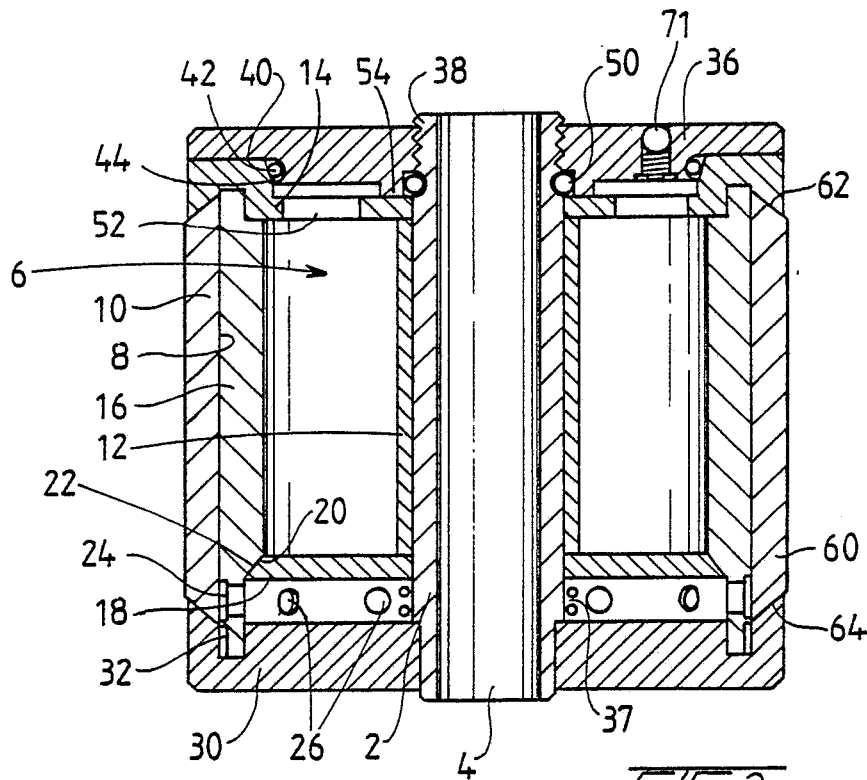
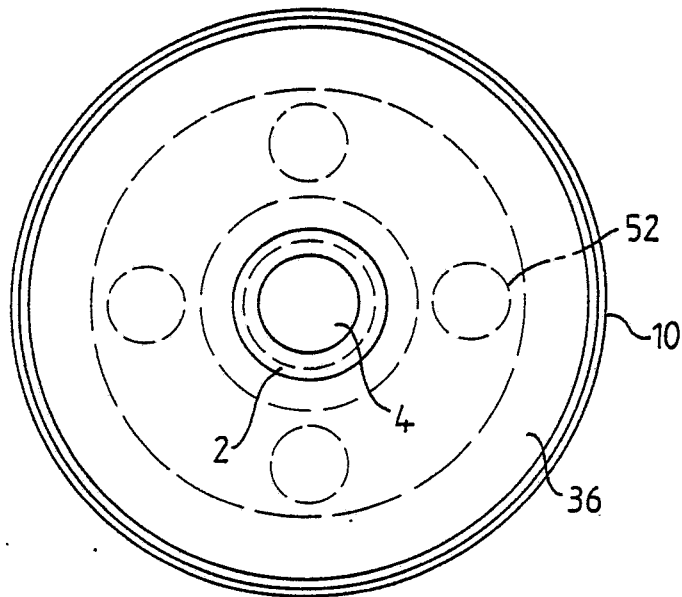

FIG 2

FIG 4

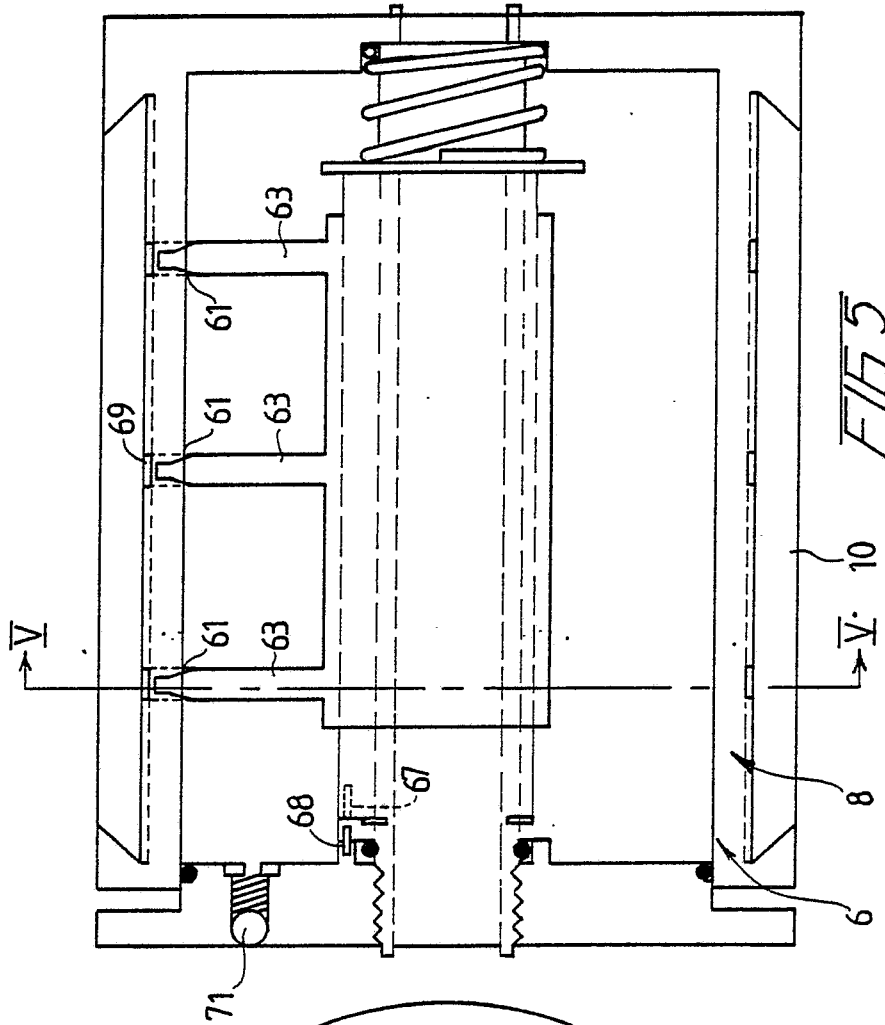
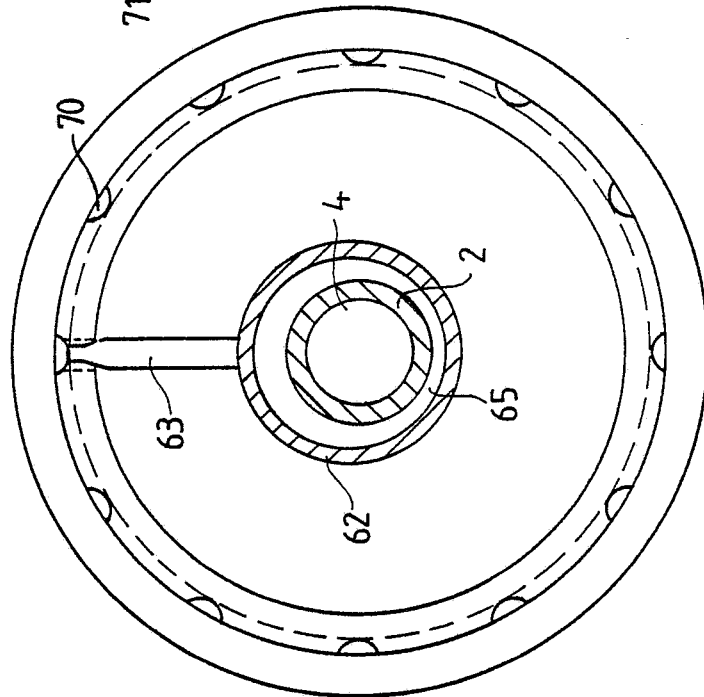

FIG 5

INTERNATIONAL SEARCH REPORT

International Application No PCT/AU 83/00101

I. CLASSIFICATION OF SUBJECT MATTER (if several classification symbols apply, indicate all) ³		
According to International Patent Classification (IPC) or to both National Classification and IPC		
Int Cl. ³ B41F 31/22, 31/26, B41J 27/12, B05C 1/10		
II. FIELDS SEARCHED		
Minimum Documentation Searched ⁴		
Classification System	Classification Symbols	
IPC	B41F 31/22, 31/26, B41J 27/12, B05C 1/10	
Documentation Searched other than Minimum Documentation to the Extent that such Documents are Included in the Fields Searched ⁵		
AU I.P.C. as above		
III. DOCUMENTS CONSIDERED TO BE RELEVANT ¹⁴		
Category ⁶	Citation of Document, ¹⁶ with indication, where appropriate, of the relevant passages ¹⁷	Relevant to Claim No. ¹⁸
X	US, A, 1398910 (POST) 29 November 1921 (29.11.21)	
X	US, A, 1731739 (DU BELLE) 15 October 1929 (15.10.29)	
X	DE, A, 1561523 (WINDMOLLER AND HOLSCHER) 27 May 1970 (27.05.70)	
X	CH, A, 557748 (GUHLAND SCHEIBLER) 30 November 1974 (30.11.74)	
A	AU, A, 40735/68 (439,264) (COLORFLO LIMITED) 22 January 1970 (27.01.70)	
A	AU, A, 55040/73 (467,186) (NORPRINT LIMITED) 7 November 1974 (07.11.74)	
<p>¹⁵ Special categories of cited documents:</p> <p>"A" document defining the general state of the art which is not considered to be of particular relevance</p> <p>"E" earlier document but published on or after the international filing date</p> <p>"L" document which may throw doubts on priority claim(s) or which is cited to establish the publication date of another citation or other special reason (as specified)</p> <p>"O" document referring to an oral disclosure, use, exhibition or other means</p> <p>"P" document published prior to the international filing date but later than the priority date claimed</p> <p>"T" later document published after the international filing date or priority date and not in conflict with the application but cited to understand the principle or theory underlying the invention</p> <p>"X" document of particular relevance; the claimed invention cannot be considered novel or cannot be considered to involve an inventive step</p> <p>"Y" document of particular relevance; the claimed invention cannot be considered to involve an inventive step when the document is combined with one or more other such documents, such combination being obvious to a person skilled in the art.</p> <p>"&" document member of the same patent family</p>		
IV. CERTIFICATION		
Date of the Actual Completion of the International Search ¹	Date of Mailing of this International Search Report ²	
22 September 1983 (22.09.83)	29 SEPTEMBER 1983 (29-09-83)	
International Searching Authority ¹	Signature of Authorized Officer ²⁰	
Australian Patent Office	P.F. Gotham <i>P.F. Gotham</i>	